

ALGE

TIMING



THE SPORTS
TIMING EXPERTS

Catalog

ALGE-TIMING

Rotkreuzstraße 39
6890 Lustenau, Austria

Tel.: +43 5577 859 66
Fax: +43 5577 859 66-4
office@alge-timing.com
www.alge-timing.com

Printing errors, mistakes, and modifications reserved.
All rights reserved.

COMPANY PROFILE



Years of experience, continuous research and development have made ALGE-TIMING an internationally successful company in the field of electronic sports timing.

Founded in 1946, the family business is run by a third generation and has specialized in sports timing since the 1970s. Today, ALGE-TIMING employs around 20 people, six of whom are constantly involved in the development of new products.

ALGE-TIMING covers the complete range of time measuring products and display systems. From the small association, to municipalities, to stadium designers or timing professionals, all customers receive competent advice and the entire product range from a single source.

ALGE-TIMING is now represented in over 40 countries, where the timing systems are distributed through an international network of independent sales partners.



TABLE OF CONTENTS



























| | | | |
|--|-----------|---|------------|
|  Company Profile | 3 | | |
|  Timing Devices | 6 | | |
| TdC8001 | 6 | | |
| Timy3 | 10 | | |
| WTN-Training Set | 12 | | |
|  Start Devices | 14 | | |
| Startclock ASC3 | 14 | | |
| Startbeep STB1 | 15 | | |
| Electronic Start System BANG | 16 | | |
| Electronic Start Gun e-Start and e-Start W | 19 | | |
| Start Microphone SM8 | 20 | | |
| Startgate STSn | 21 | | |
| SSD1 | 22 | | |
|  Impulse Devices | 24 | | |
| Photocell PR1a and PR1aW | 24 | | |
| Photocell | 26 | | |
| Photocell Accessories | 27 | | |
| Accessories | 28 | | |
|  Cables & Adapters | 30 | | |
|  Radio Devices | 32 | | |
| Teledata TED400 | 32 | | |
| Wireless Timing Network WTN | 35 | | |
|  Photo Finish | 37 | | |
| OPTIc3 | 37 | | |
| OPTIc3 Accessories | 41 | | |
|  Monitoring of the Finish Line | 42 | | |
| IDCam | 42 | | |
|  Display Board | 46 | | |
| GAZ5 | 46 | | |
| D-LINE | 48 | | |
| LED Matrix D-RTNM | 50 | | |
| Video Wall | 52 | | |
| Lap Counter D-LC | 56 | | |
| Time Temperature Display Board D-SAT | 57 | | |
|  Athletics | 58 | | |
| Windspeed WS2 | 60 | | |
| False Start System Start Judge SJ2 | 62 | | |
| Infield Display Boards | 64 | | |
| Concentration Clock CC | 66 | | |
| Distance Measuring Devices (Theodolites) | 67 | | |
|  Cycling | 68 | | |
| Road / Road Race | 70 | | |
| Road / Time Trail | 71 | | |
| Track Cycling / Timing System | 72 | | |
| Track Cycling / CycleStart | 74 | | |
| | | Track Cycling / Track Cycling Startmachine ST-BSM1 | 76 |
| | | Mountain Bike / Downhill | 78 |
| | | Mountain Bike / Cross Country and Speed | 79 |
| | |  Show Jumping | 80 |
| | | Time Measuring System with TdC8001 | 82 |
| | | Timing System with Timy3 | 83 |
| | | Components of the System | 84 |
| | | Endurance | 85 |
| | |  Horse Racing | 86 |
| | | Timing Setup | 87 |
| | | Accessories | 88 |
| | | Display Boards | 89 |
| | |  Swimming | 90 |
| | | Semi-Automatic Timing System | 92 |
| | | Semi-Automatic Timing System with Radio | 93 |
| | | Automatic Timing System | 94 |
| | | Automatic Timing System Components | 98 |
| | | Touchpad TP2400 / TP1800 / TP980 | 100 |
| | | Starting Block | 102 |
| | | Training | 103 |
| | | Display Boards | 104 |
| | | OPTIc3 Video Backup | 106 |
| | | Open Water | 107 |
| | | Artistic Swimming | 108 |
| | |  Diving | 109 |
| | |  Water Polo | 110 |
| | | Scoreboards | 110 |
| | | Shot Clock | 111 |
| | |  Rowing / Canoeing | 112 |
| | | Simple Timing System | 112 |
| | | Professional Timing System | 113 |
| | |  Motor Sports | 114 |
| | | Dragsters | 116 |
| | | Rally | 117 |
| | |  Sport Climbing | 120 |
| | | Speed Climbing | 120 |
| | |  Alpine Skiing | 122 |
| | | Simple Timing Solutions | 124 |
| | | FIS Timing System | 125 |
| | | Training System | 126 |
| | | Selftimer SF3 | 127 |
| | | Speedy | 130 |
| | |  Cross-Country Skiing | 132 |
| | | Individual Start | 133 |
| | | Pursuit | 134 |

TABLE OF CONTENTS



| | | | |
|---|------------|--|------------|
| Relay and Mass Start Competitions | 135 | D-M6SP | 172 |
|  Ski Jumping | 136 | D-M6SPP | 173 |
| Installation | 137 | D-M6SPFP | 174 |
| Judge Terminals and Speed Measurement | 138 | D-M6SBHV | 175 |
| System Overview | 139 | D-L1S | 176 |
|  Speed Skating | 140 | D-L3S | 177 |
|  Short Track - Inline Skating | 142 | D-L3SP | 178 |
|  Bob - Luge - Skeleton | 143 | D-L4SH2 | 179 |
|  Soccer / Football | 144 | D-L4SV2 | 180 |
| Scoreboards | 145 | D-L5S | 181 |
| Ball Sports - Ball Speed BS-R | 152 | D-L6S | 182 |
|  Tennis | 154 | D-L6SP | 183 |
|  Multisport Scoreboard | 156 | D-L6SPP | 184 |
| General Information | 157 | D-L6SPFP | 185 |
| Customized Scoreboards | 160 | D-LS-BHV-H | 186 |
| Tabletop Scoreboards | 161 | D-LS-BHV-V | 187 |
| D-S1S | 162 | D-LS-FIBA | 188 |
| D-S3S | 163 | Shot Clock D-SC | 189 |
| D-S5S | 164 | Basketball System | 190 |
| D-M1S | 165 |  Ice Hockey | 191 |
| D-M3S | 166 | D-M4SH2H and D-M5SH2H | 191 |
| D-M3SP | 167 | D-L4SH2H and D-L5SH2H | 192 |
| D-M4SH2 | 168 | Accessories | 193 |
| D-M4SV2 | 169 |  Weightlifting | 194 |
| D-M5S | 170 |  Judo | 195 |
| D-M6S | 171 |  Karate | 196 |
| | |  Taekwondo | 197 |



TIMING DEVICES

TdC8001

The TdC 8001 is a proven, universal timer for professional timing. Integrated in a handy, sturdy case, the TdC8001 proves itself useful with universal timing software, at every event. Two separate operator panels and large, easy-to-read displays support the user-friendliness of the device.

The Special Features of the TdC8001

- high accuracy due to temperature-compensated quartz oscillator TCXO
- large, easy-operating buttons
- fast thermal printer with easy paper change
- separate operator keypad for start and finish allows it to be used by two operators at the same time
- large, easily readable displays for bib numbers and times on seven-segment LCD displays
- alphanumeric LCD display for operator guidance and information
- real-time clock replaces manual input of time of day (battery life approx. 10 years)
- printer buffer allows simultaneous printing and timing, as well as subsequent printing of times, for example, after paper change
- 10 independent timing channels (e.g. start, 8 intermediate times, finish)
- integrated speech amplifier to connect a headset for interference-free speech connection between the start and the finish, via a two-wire start cable
- integrated NiMH rechargeable battery ensures independent all-day operation, even in cold weather
- stylish, sturdy case with detachable lid
- instant ranking within groups (helps the announcer)
- universal programs for many different sports included
- enormous storage capacity for up to 9,999 times per race, with bib input up to 9,999
- four races can be saved with identical bibs
- buffer (9,999 times) for mass arrivals
- each time impulse is stored (time of day), no time is lost
- printout of the ranking list in any usual form
- large temperature range, also works in cold temperatures down to -25 °C without heating
- easy allocation of bibs to stopped times
- each time correction is marked
- automatic mode with automatic update of start and finish start number
- interfaces for scoreboards, PC (race evaluation) and data transmission with radio



TIMING DEVICES

TdC8001



Program SPLIT

- program to measure run times
- start channel, 8 intermediate time channels, finish channel
- precision adjustable to 1/1,000, 1/100, 1/10 or second
- up to 256 runs (heats)
- individual, start, group start or mass start
- time of day or absolute measuring
- up to 9,999 participants on the course, at the same time
- ranking list

Types of Sports: alpine skiing, cross-country skiing, biathlon, mountain bike, white water canoe, motor sport, etc.

```

ALGE TIMING
Tdc 8001
ENG V 03.51

Program 1: V01.72
SPLIT

Work on:
Race 1
Heat 1

Precision: 1/100 s

Timing:
DIFFERENCE

Startmode:
SINGLE START

Channels on:
0,1,2,3,4,5,6,7,8,9

Synchronitime:
= 09:00:00

0001 ST 9:46:02.8702
    FT 9:47:21.4133
    RT 1:18.54
0002 ST 9:46:02.8618
    FT 9:47:31.2779
    RT 1:21.72

Heat 2

Precision: 1/100 s

Timing:
DIFFERENZ

Startmode:
BIBO: 15

0001 ST 10:48:16.1121
    FT 10:49:27.6383
    RT 1:11.52
0002 ST 10:48:24.7473
    FT 10:49:35.0293
    RT 1:10.28
    MT 1:21.29
    TT 2:31.57

Classement:

ALL

TOTAL TIME

1.
0001 RT 1:11.52
    MT 1:18.54
    TT 2:30.06
2.
0002 RT 1:10.28
    MT 1:21.29
    TT 2:31.57
    
```

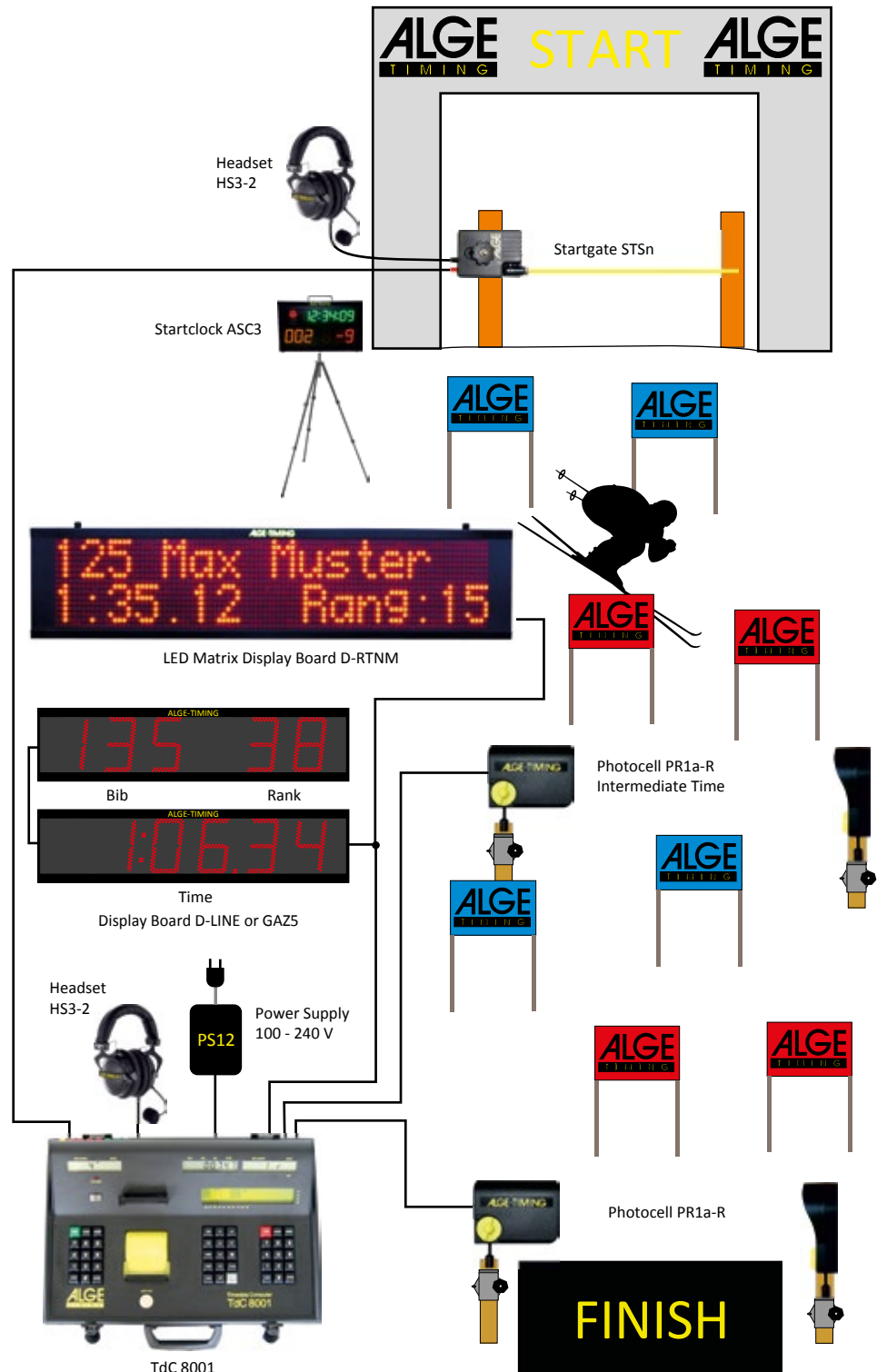

TdC 8001



TIMING DEVICES

TdC8001

Timing Examples

Parallel Slalom

Parallel slalom with difference time

- difference time between both competitors
- identification of the winner (red or blue)

Types of Sports: skiing, snowboarding

Parallel slalom with net time and difference time

- parallel start for both competitors
- run time of both competitors
- difference time between both competitors
- identification of the winner (red or blue)
- total run time after changing the slope
- total difference time after change of slope

Types of Sports: skiing, snowboarding

Equestrian / Show Jumping

Contains all jumping competitions of the FEI

- standard show jumping
- standard show jumping test with two rounds
- time jumping
- two-phase jumping
- american jump-off
- standard jumping test and time jumping test
- team jumping
- carriage driving
- etc.

| | | | |
|------|-----|---------------|--|
| 0014 | C9 | 11:23:14.5900 | Count-down Start |
| | CD | 13.92 | Start at 13.92 of the count-down |
| 0014 | SZ | 11:23:45.6653 | Start time (daytime) |
| | P | + 4.00 | 4 penalty points |
| | C9 | 11:24:14.6926 | Time-out start |
| | TO | 29.02 | Time-out run time |
| | PTO | + 6.00 | 6 penalty seconds |
| | C9 | 11:24:25.0320 | Time-out end |
| | P | + 4.00 | 4 penalty points finish time (daytime) |
| | ZZ | 11:24:52.1161 | Run time |
| | LZ | 56.11 | Penalty seconds |
| 0014 | PTO | 6.00 | Penalty points for exceeding the time |
| | PTM | 2.00 | Penalty points for obstacle drops |
| | FP | 8.00 | Total run time |
| | LZT | 62.11 | Total penalty points |
| | TP | 10.00 | |

Example: Print out of standard show jumping

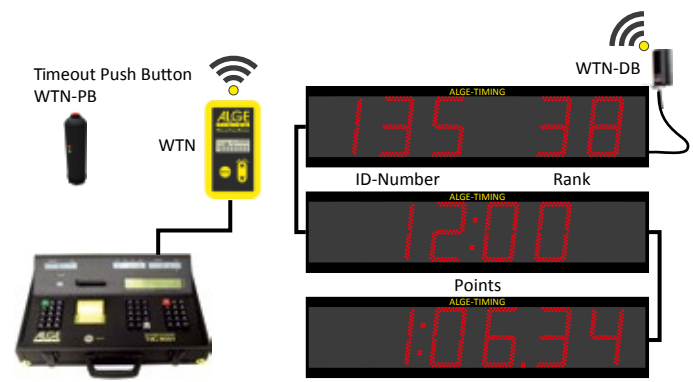
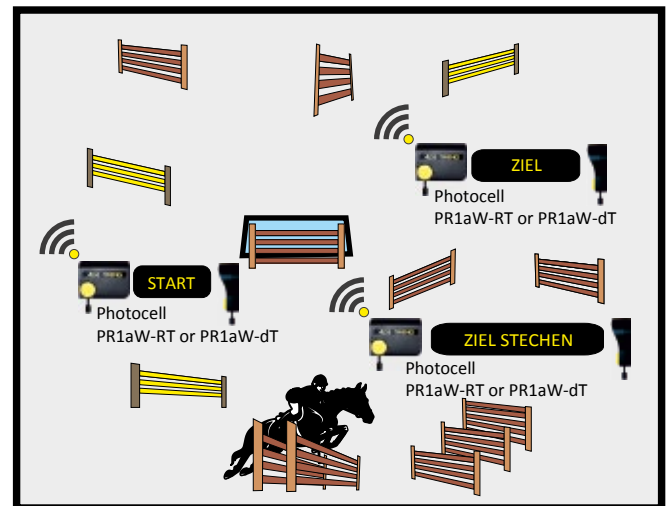
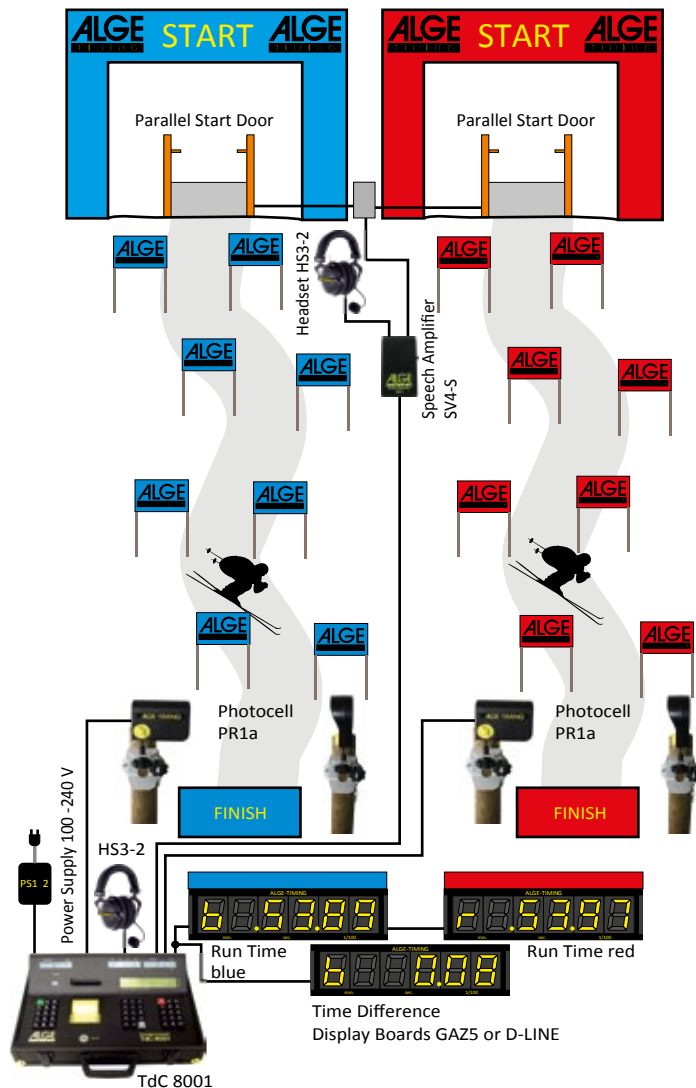

TIMING DEVICES

TdC8001



DUAL TIMER

- timing on two courses simultaneously
- measurement of intermediate and run times
- calculation of total time after reversal of courses
- separate or combined start

- only one racer on each course
- selectable calculated precision from 1/1,000 to 1 second
- results for each course individual or combined

Recommended for: alpine skiing, snowboarding

Other Software

Speed

- adjustable measuring distance from 1 to 9,999 meter
- display and printout in km/h, m/s and mph
- bidirectional measurement possible

Types of sports: motor sports, skiing, ski jumping, cycling

Street Cycling

- measures the winning time
- shows of the average speed of the winner
- shows the time difference between winner and others

Types of sports: street cycle racing

Motor Sports

- mountain racing
- car slalom
- dragster races

Speed Skating

- automatic lane change
- shows on separate display boards times of competitors

Dog Agility

the software includes the following programs for agility:

- dog agility
- gambler

Speed Skiing

- fixed speed measurement at 100 meter
- display and printout of start, run time and speed
- ranking list

Technical Data

| | |
|----------------------|--|
| Measuring range: | 23 hours, 59 minutes, 59.9999 seconds |
| Time reference: | TCXO (temperature compensated crystal oscillator) |
| Frequency deviation: | +/- 0.1 ppm at 25 °C (+/- 0.00036 s/h) |
| Areas of use: | -25 °C to 50 °C |
| Electronics: | state-of-the-art C-MOS technology |
| Memory: | approx. 2 x 10,000 times with start numbers, keeps data when switched off by internal rechargeable battery |
| Display: | start display (1): numeric liquid crystal display 8 digits, figure height 12.7 mm finish display (5): numeric liquid crystal display 8 digits, figure height 12.7 mm finish display (6): numeric liquid crystal display 8 digits, figure height 12.7 mm info display (7): alphanumeric liquid crystal display, 4 x 40 characters, figure height 4.8 mm |
| Operating elements: | on/off switch (g), start keyboard (12) with 15 keys, function keyboard (9) with 15 keys, finish keyboard (8) with 15 keys |
| Power supply: | internal: NiMH rechargeable battery 7.2 V/4.5 Ah external: 100 - 240 VAC (alternative 115 VAC) with charger PS12 |
| Power consumption: | no external devices, from the internal NiMH battery: about 80 mA; when printing: about 500 mA |
| Charging supply: | 11 - 16 VDC |
| Output: | stabilized with 5 VDC: total maximum 120 mA |
| Interfaces: | RS232 interface for PC; RS232 and RS485 interface for display boards |
| Loudspeaker output: | for 8 Ω speaker |
| Casing: | lockable case with removable cover, front panel aluminum |
| Dimensions: | 450 x 320 x 150 mm |
| Weight: | 7.5 kg |



Operation elements and connectors

- 1 - start display
- 2 - LED charging status light
- 3 - meter to monitor power supply and photocell
- 4 - paper roller
- 5 - run time display
- 6 - start number display for the finish
- 7 - info-display, alphanumeric with 4 x 40 characters
- 8 - finish keyboard
- 9 - function keyboard
- 10 - paper feed button
- 11 - paper tray with thermal printer
- 12 - start keyboard



- a - connection for multi channel
- b - volume for headset
- c - socket for headset
- A/A socket for photocell and supply (identical)
- B - socket for photocell and supply (different channels)
- C - socket for photocell and supply (different channels)
- d - socket for RS232 and RS485 (2x)
- e - socket to connect a display board
- f - socket to connect a speaker
- g - on/off switch
- h - banana sockets for all 10 timing channels
- i - banana socket for display board



TIMING DEVICES

Timy3

The ALGE-TIMING Timy3 is a compact timing device with unique, high-quality technology. The Timy3 impresses with an ergonomic design and absolute reliability, thanks to its robust design.

Despite its handy dimensions, the Timy3 has a large and easy-to-use silicone keypad, which can be used in any weather conditions, even with gloves on. The printer is integrated into the Timy3 WP and logs times of the entire competition.

The Timy3 has an internal wireless modem of the Wireless Timing Network WTN series. The Timy3 can be connected via radio to all devices of the WTN series, and, for example, can receive start impulses, intermediate times and finish impulses, control a display board and send data to a PC with result software.

The low power consumption allows it to be used even in cold weather with internal batteries independent from mains.

The Timy3 is equipped with all necessary interfaces for communication with external devices, a USB interface, an interface for a display board, an RS232 and an RS485 interface.



Display

The Timy3 has a monochrome LCD graphic display with 128 x 64 pixels and backlight. With this, displaying up to 8 lines of text is possible. Different character sizes, and also graphic symbols for easier operation, can be displayed. The display has an extended temperature range for use in extreme weather conditions (up to -20 °C).

Keypad

Despite its compact dimensions, the Timy3 has a large and easy-to-use silicone keypad, with 26 keys. Even with gloves on, an easy use is ensured.

Accuracy

The Timy3 works on a time of day basis and records it with an accuracy of 1/10,000 seconds. That means that calculated net times of a precision of 1/1,000 seconds are exactly calculated. Highest accuracy at any temperature is guaranteed by a temperature-compensated quartz.

Printer

The Timy3 WP has an integrated thermal printer. This quiet and extremely

fast printer allows easy and simple paper change. The transport roller is connected to the paper cover and saves the tedious threading of the paper.

Memory

Approximately 30,000 times can be stored with the corresponding bib and timing channels. The software is stored in a flash memory. Updates of the software are available free of charge, via the Internet.

Casing

Particular emphasis was placed on ergonomics and stability. The aim of the development was to bring a timer with all the advantages of modern technology into a handy and shock-proof casing. The Timy3 is suitable both as a hand-held timing device and as a table device.

Connections

Regarding the wide range of possible connections with external devices, the Timy3 offers unequalled opportunities in its class and size. For example it is possible to connect several devices by the RS485 interface to work as a network.

Radio Network - Wireless Timing Network WTN

An integrated WTN module allows to communicate with all devices in the WTN series (WTN wireless radio, WTN-PB wireless push button, PR1aW photocell, WTN-DB and Windspeed WTN-WS scoreboard).

Software

There is a great number of programs for the Timy3. The device is able to cover the entire spectrum for time measurement starting from a hand timer up to the main timer at major events.

TIMING DEVICES

Timy3



Timy3 Software

| | |
|-----------------|--|
| Backup: | timing device to measure time of day (e.g. backup or reference timer for PC) |
| Stopwatch: | universal timing program which is able to time more than one run (net time/total time) |
| TrackTimer: | timing for events which have lanes (e.g. athletics and swimming) |
| LapTimer: | timing program with split and sequential time |
| PC-Timer: | professional timer (time of day) to work with a PC |
| Timeout: | timing program with timeout function (e.g. show jumping) |
| Dual timer: | timing program with two courses, either with simultaneous or separate start |
| Parallel-Diff: | timing program for parallel slalom |
| TV timer: | simple timing program to control a display board or TV time insert |
| Speed climbing: | timing program for speed climbing |
| Training light: | universal training software with intermediate times and one racer on course |
| Training REF: | training software with intermediate times and more than one racer on course |
| Swim trainer: | training program for swimming |
| Speed: | speed measurement in km/h, m/s, or mph |
| Commander: | terminal to control ALGE-TIMING display boards |
| Terminal: | terminals for judges (e.g. ski jumping, figure skating, diving, artistic swimming) |
| CycleStart: | start control, lap counting and backup timing for pursuit cycling |
| Windspeed: | to measure the windspeed for athletics with a connected anemometer WS2 |
| Jumping: | training program for jumping exercises |



Timy3 W timing device without printer

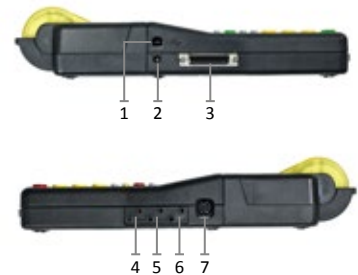

Connections:

- 1 - 1 x USB
- 2 - 1 x power supply 8 - 22 VDC
- 3 - 1 x D-Sub 25-pin
- 4 - 1 x pair of banana sockets - scoreboard
 - 9 time measuring channels
 - RS232 (PC connection)
 - display board
 - RS485 (network)
 - power supply (8 - 24 VDC in/out)
- 5 - 1 x pair of banana sockets - start input
- 6 - 1 x pair of banana bushes - finish entrance
- 7 - 1 x DIN socket for photocell



Technical Data

| | | | |
|--------------------|--|----------------------|---|
| Crystal frequency: | TCXO, +/-1 ppm (+/-0.00036 s/h) | Power supply: | internal: NiMH power pack 7.2 V/2 Ah or 6 x AA alkaline (only for Timy3 W) external: power supply PS12A, 12 V battery or 8 - 22 VDC |
| Time resolution: | 1/10,000 s | Power consumption: | without printer about 100 hours with printer about 47 hours |
| Timing: | 9 timing channels, external extension possible | Charging time: | approx. 14 hours |
| Program memory: | flash memory with 16 Mbit | Printer: | graphic thermal printer, max. 5 lines per second |
| Data memory: | RAM with 4 MBit (about 30,000 times) | Temperature range: | -20 °C to +60 °C |
| Display: | monochrome LCD graphic display with backlight, 128 x 64 pixels, extended temperature range | Measurements: | Timy3 W: 204 x 91 x 50 mm Timy3 WP: 307 x 91 x 65 mm |
| Keypad: | silicone keypad, 26 keys | Weight (no battery): | Timy3 W: 450 g Timy3 WP: 650 g (without battery and paper) |
| Radio module WTN: | built-in 2.4 GHz radio, 15 adjustable frequencies and power output from 10 to 100 mW, 5 timing channels, for distances up to 350 m | | |



TIMING DEVICES

WTN-Training Set

The WTN-Training set combines the highest precision with reliability and ease of use. The system for timing in training includes a timer, two photocells with reflectors including four tripods. In the robust plastic case, the WTN-Training set can be safely and comfortably transported to the next workout.

The wireless WTN-Training set communicates via the Wireless Timing Network (the time-measuring radio network developed by ALGE-TIMING), which ensures reliable radio transmission of impulses and data. It guarantees the highest possible timing accuracy. In case of a radio interference it can transmit the data delayed by using a special technology and can transmit the data later in the event of radio interference. The timing device then corrects the time to that of the original impulse.



Timy3 W

Timy3 WP



Photocell PR1aW

Advantages of the WTN-Training Set

- new, intuitive system that works with radio
- simple, easy and fast setup of the complete system
- compact measurements proven ALGE-TIMING robustness
- simple systems operation
- timing device Timy3 has a lot of software applications
- highest timing precision by temperature compensated quartz (measuring of 1/10,000 seconds)
- fully featured timing device that can be used for the timing of races as well
- measuring of speed in km/h, m/s or mph possible
- timing device has an USB-interface for easy transfer of training data to a PC
- photocell with integrated radio
- up to 5 different timing channels are adjustable at photocell
- possibility to add additional photocells or other impulse devices
- complete system is battery powered and works about 35 hours
- 15 different radio channels are adjustable
- system is made to be used outdoor
- stable case with foam insert for easy and safe transport

TIMING DEVICES

WTN-Training Set



Two different sets are available

The main difference between the two sets is that the WTN-Set 1 has no printer integrated in the timing device. The WTN-Set 2 has a timing device with integrated printer.

WTN-Set 1 includes

- 1 x timing device Timy3 W including alkaline battery
- 2 x photocell PR1aW
- 2 x reflector Ref-L
- 4 x tripod TRI-S5
- 1 x case for complete set

WTN-Set 2 includes

- 1 x timing device Timy3 WP including rechargeable battery set and charger
- 2 x photocell PR1aW
- 2 x reflector Ref-L
- 4 x tripod TRI-S5
- 1 x case for complete set

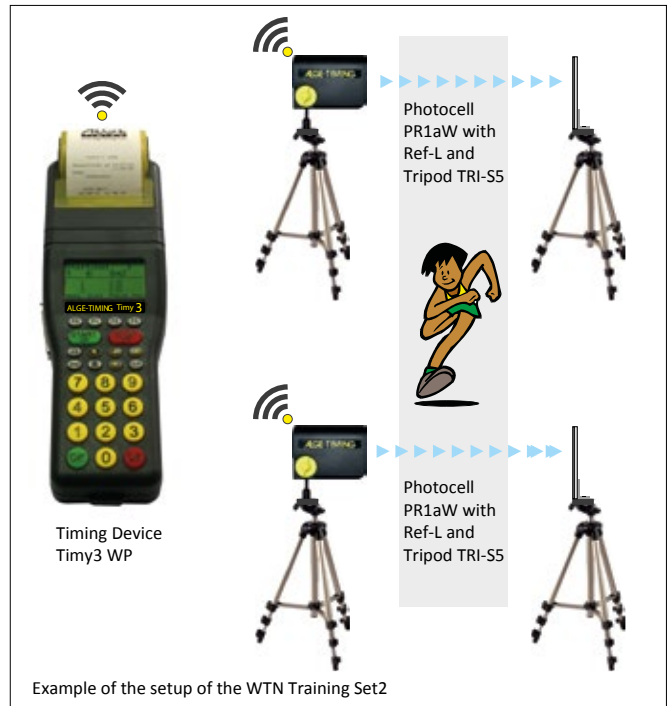

case KL-WTN-SET to transport and store the entire system, including tripods





START DEVICES

Startclock ASC3

The Startclock ASC3 is an important device for the professional handling of the start. It is equipped with the latest LED technology and provides accurate start information for the partici-

pants and start judge. The ASC3 is optimally readable at daytime or night. The battery-driven Startclock ASC3 is used for various sports like alpine skiing, cross-country skiing, biathlon, rally etc.

Facts about the Startclock ASC3

- LED technology
- shows the time of day (hours, min. and sec.), green LEDs
- figure height of time of day digits is 55 mm
- shows the bib (ID-number), yellow LEDs
- figure height for bib digits is 70 mm
- shows the countdown in minutes and seconds, red LEDs
- figure height of countdown digits is 70 mm
- start light with red, yellow and green LED cluster
- integrated speaker with volume regulation
- RS232 interface to connect a PC or printer (parameters of ASC3 can be adjusted by computer)
- integrated rechargeable lead battery for operation independent from mains supply
- two internal push buttons to set parameters of ASC3
- start input (banana socket)
- sync. input or countdown start (banana socket)
- potential free impulse output (banana socket)
- output for external speaker (4 - 8 Ω)
- startlist can be loaded to ASC3
- external power supply (12 -16 VDC or 85 - 264 VAC)
- LED to control battery condition and charging
- flash memory allows update
- remote Control ASC3-RC with 10 m cable length to operate the Startclock ASC3



Remote Control ASC3-RC

Technical Data

| | |
|----------------------|---|
| Unit of Measurement: | 1/1,000 second |
| Measuring range: | 23 hours, 59 minutes, 59.9999 seconds |
| Accuracy: | +/- 0.3 ppm (+/- 0.001 s/h) |
| Time base: | temperature compensated real time clock |
| Display: | extra bright LEDs for outdoor use, brightness adjustable 8-digit LED display, height 55mm, for time of day 3-digit LED display, height 70mm, for bib (ID-number) 3-digit LED display, digit height 70mm, for countdown Start light with red, yellow and green LED cluster, each 35 mm diameter |
| Temperature range: | -25 °C to +65 °C |
| Power supply: | integrated power pack (rechargeable battery (12 VDC, 12 Ah) and charger or external battery (12 - 16 VDC) or mains (85 - 264 VAC) |
| Operating time: | about 20 hours from internal battery at 30 seconds intervals and 20°C |
| Case: | anodized aluminum with cover and hanging mounting brackets, 3/8" thread for tripod (tripod not included) |
| Dimensions: | L x H x D = 445 x 280 x 115 mm (without hanging mounting brackets and handle) |
| Weight: | 8.4 kg |

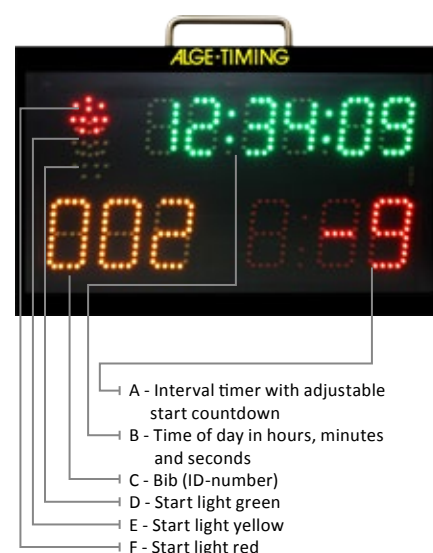

START DEVICES

Startbeep STB1



The Startbeep STB1 is a universal, start acoustic device. Due to its sturdy construction, the STB1 is very simple and user-friendly to operate.

Startbeep STB1

- Nine fixed programmed start intervals can be selected with a switch: 10, 15, 20, 30, 40, 45, 60, 90, and 150 seconds.
- A freely programmable start interval can be selected between 6 and 99:59 minutes with step switch.
- a special program for the 3-second countdown in speed climbing
- countdown start by internal or external push button
- countdown with or without standby signal (ten seconds before start)
- In the horn mode, the Startbeep can be used as a start gun replacement, triggered by an internal or external push button.
- It can be synchronized with other timing devices.
- start output, potential-free closed contact (e.g. for triggering a timing device)



Technical Data

| | |
|----------------------|---|
| Electronics: | μP-controlled in CMOS technology |
| Working temperature: | -25 °C to +45 °C |
| Power supply: | 9 V Alkaline battery or external power supply |
| Connections: | <ul style="list-style-type: none">· potential-free closing contact for synchronizing or the triggering of a timing device· external push button· external power supply· on/off switch· internal push button |
| Sound converter: | horn loudspeaker, swiveling |
| Housing: | polyamide, glass fiber reinforced (impact resistant) |
| Fastening: | chain fastening e.g. for mounting on a post |
| Weight: | 1 kg |
| Dimensions: | 132 x 205 x 88 mm |
| Operating duration: | up to 80 hours |





START DEVICES

Electronic Start System BANG

The electronic start system consists of a transportable amplifier box with an active loudspeaker that has 80 W max and makes an efficient start possible without great effort thanks to the integrated connection to the timing system.

The starter can talk with the BANG-HS radio microphone via the amplifier box BANG, for example, to give start commands for the athletes. It is possible to combine several amplifier boxes BANG.

The start shot is triggered via a closing contact. For competitions that require a flash, the electronic start trigger e-Start with integrated flash is used. This start impulse device has an advantage with hearing impaired athletes or for more precise hand timing.



Options

Wired System BANG

The BANG receives the start impulse via a cable from an impulse device. With the radio microphone BANG-HS the BANG can be used by radio for announcements.

Wireless System BANG W

The BANG W receives the start impulse by radio from an impulse device. The BANG W contains an integrated wireless module of the product series Wireless Timing Network WTN. It is not possible to connect an impulse device via a cable to the BANG W.

Cable/Radio System BANG CW

The BANG CW receives the start impulse by cable from an impulse device (e.g. e-Start). In addition, a wireless module WTN is integrated. A false start impulse can be triggered via cable or radio (e.g. radio push button WTN-DB). It is not possible to use the BANG-HS radio microphone with this model.



- 1 - receiver for radio microphone
- 2 - cable connection for BANG to timing device(s)
- 3 - Wireless Timing Network WTN (radio module) for BANG W
- 4 - ON/OFF-switch
- 5 - speaker amplifier (settings and connections)
- 6 - connection for power supply (90 - 265 V~)

START DEVICES

Electronic Start System BANG



Advantages of the BANG launching system

- Start system is always ready, no reloading of a gun necessary.
- No starting problems due to unloaded start guns or bad blanks.
- no costs for expensive blanks
- There is no cleaning of guns necessary after the end of a race day.
- no legal problems with the use of the Start System (in many countries a gun license is necessary for a start gun)
- no problems to transport the Start System BANG (in many countries the gun and ammunition must be transported in separate vehicles)
- When using the "Start Unit SU3", it is possible to communicate with the time keeper and to make announcements over the speakers of the Start System (e.g. Start Judge SJ2) and the BANG.



BANG-HS

Headset with radio microphone to talk via the BANG or BANG W



BANG-TRI

Tripod for BANG series with adjustable height from 107 - 157 cm



BANG-BAG

Splash-proof protection cover for the BANG series, with the front side made of sound-permeable mesh fabric



BANG-SPK

Horn loudspeaker as extension for the BANG series (up to 8 BANG-SPKs can be connected)



FLASH XL

Start flash (LED with battery) e.g. for hearing impaired athletes



e-Start

Start impulse generator (start gun replacement for starter) with integrated flash for cable connection to BANG or BANG CW and timing system



e-Start W

Start impulse generator (start gun replacement for starters) with integrated flash light and radio connection (WTN) to BANG W and timing system



START UNIT SU3

Amplifier for communication via a speaker-telephone



Headset HS3-2

Headset for communication with timer and for voice commands via BANG or BANG CW



Start Microphone SM8

The start microphone generates an electrical impulse from the shot of a starting gun.



START DEVICES

Electronic Start System BANG

The Start System BANG is ideally suited for combining with other ALGE-TIMING devices and can be used with one or more BANG amplifier loudspeakers.

The sketch below shows the BANG W, which is connected by radio to an electronic start impulse generator e-Start W, replacing the traditional start guns. If the start device e-Start W is triggered, a start impulse is transmitted by radio to the speaker BANG W and to the timing device (e.g. Timy3 WP). The BANG W emits a shot imitation on the loudspeaker through the impulse.

The starter gives commands for the athletes via the radio headset BANG-HS (e.g. "your marks" and "get set").

The Start System BANG CW (see drawing below) can be combined with the Start Judge SJ2. The e-Start triggers the loudspeaker BANG CW and the loudspeakers placed on the start blocks that imitate a shot. If the starter triggers the e-Start a second time within 5 seconds, a false start signal is emitted via the loudspeakers. With the radio push button WTN-PB, the Start Judge SJ2 can only trigger the false signal.

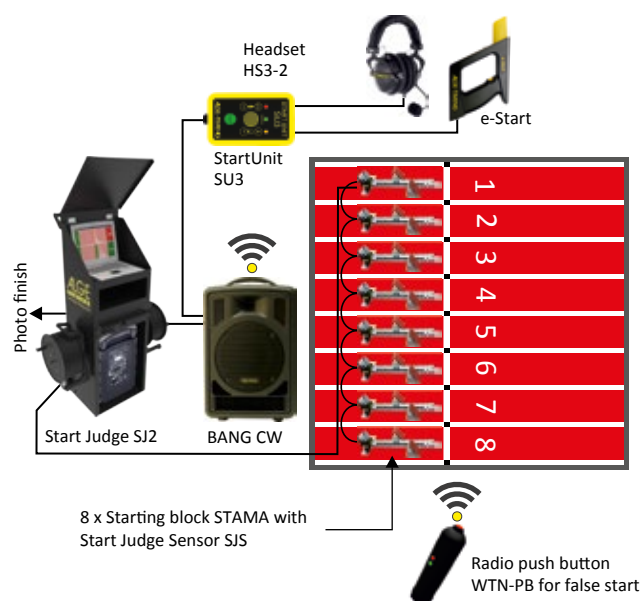
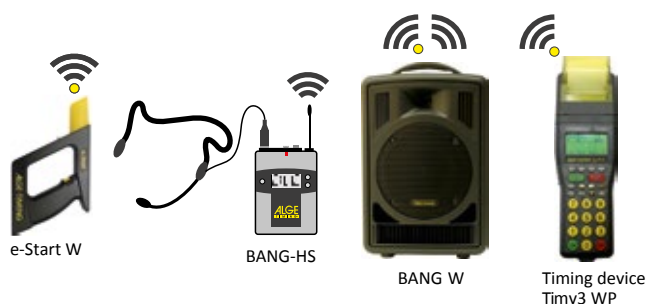

Technical Data

| | |
|------------------------|---|
| Output power: | 80 W_max/50 W_rms |
| Speaker system: | 2-way speaker system 20 cm bass speaker (8"), 2.5 cm tweeter (1") |
| Frequency range: | 20 - 20,000 Hz |
| Mic input: | 6 mV |
| Line inputs: | 800 mV |
| Timing: | 2 x LTW-socket (7-pin, male) 1 x DIN-socket (5-pin, female) 1 x banana socket (green and black) |
| Equalizer, Bass: | ± 15 dB/100 Hz |
| Equalizer, Treble: | ± 10 dB / 10 kHz |
| Power supply: | mains: 90-265 V~ / 47-63 Hz / 150 VA battery: 2 x 12 V/3 Ah (built in) |
| Operating temperature: | 0 °C to +40 °C |
| Measurements: | 300 x 470 x 230 mm (L x H x W) |
| Weight: | 11.2 kg |

Receiver for Headset BANG-HS

| | |
|--------------------|---|
| Receiver module: | PLL multi-frequency receiver in diversity technique |
| Carrier frequency: | 863.1 - 864.9 MHz divided over 16 frequencies |
| Operating range: | about 30 m |

START DEVICES

Electronic Start Gun e-Start and e-Start W



The electronic starting device combines absolute precision and synchronization of start signal, flashlight and start tone, and replaces traditional start guns. With this device, problems by transporting weapons have become history.

The electronic start gun is connected directly to ALGE-TIMING devices, such as the BANG loudspeaker system or the Start Judge SJ2 system. It has a push button that triggers the flash and start impulse that are passed on to the other components of the system.

The e-Start is connected by cable; the e-Start W is the radio system.

Facts about the electronic Start Gun e-Start/e-Start W

- fair starting conditions for all starters
- best visibility through a flash for start and/or false start
- no additional costs for cartridges
- no problems with the start due to defective ammunition or unloaded gun
- no weapon certificate required
- no problems with transport or with customs authorities

Technical Specifications

Flash: 4 x LED (Ultra Bright Power LED)
 Operating temperature: -20 °C to +45 °C
 Dimensions: 265 x 150 x 35 mm

e-Start Specifications

Weight: approx. 0.3 kg
 Connector: 2 m long connection cable with DIN plug

e-Start W Specifications

Weight: approx. 0.5 kg
 Connection: via integrated WTN radio module
 Transmission frequency: 2.4 GHz band, 15 adjustable teams
 Battery: Li-Ion battery 3.6 V/10.4 Wh (fixed installed)
 Charging time: approx. 4 hours (charging temperature 0 °C to 45 °C)
 Operating time: approx. 45 hours at 22 °C and one impulse per minute



Start gun e-Start



Start gun e-Start W

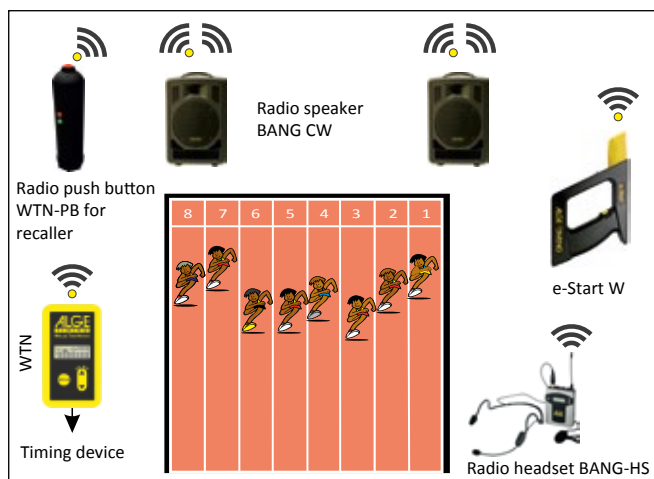
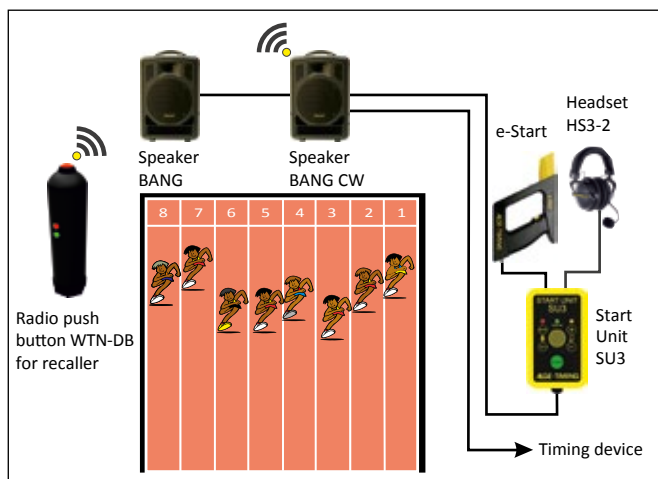



START DEVICES

Start Microphone SM8

The start microphone SM8 is used in all sports that are started with a start gun, such as in athletics, triathlon, cycling, speed skating, short track or cross-country skiing.

The SM8 start microphone is mounted on a start gun. The report (sound of detonation) of the start gun triggers an electrical impulse in the start microphone SM8 and starts the timing device.

The SM8 start microphone is connected to the SV4/SM speech amplifier, from which a two-wire cable with banana plug leads to the timing device. In addition, a headset can be connected to the SV4/SM speech amplifier, which allows direct communication between starter and timing operator. The same two-wire cable is used for the voice connection as for the start impulse.



Start microphone SM8

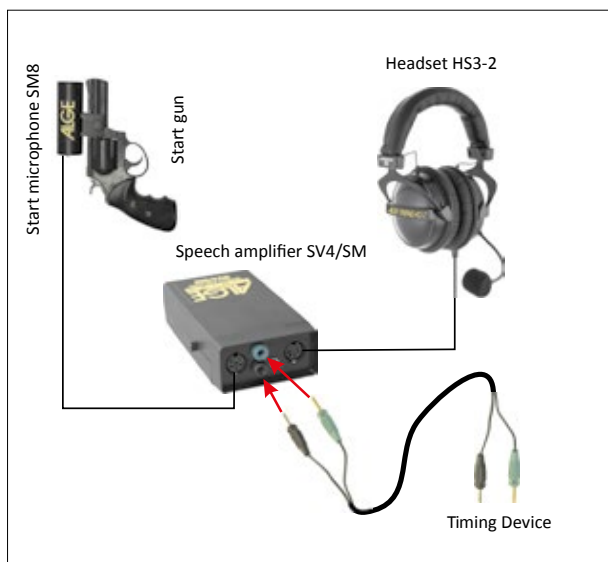

START DEVICES

Startgate STSn



The startgate is used mainly at the start for individual start, e.g. alpine skiing, cross country skiing, snowboarding, etc., and is installed at the start between two poles so that the competitor can only leave the start when he moves the startwand of the startgate.

In order to fix the startgate to the post, a chain support is attached, i.e. the chain attached to the startgate is placed around the post and then tightened on a locking screw with a toggle.



There are different types of startgates

STSnM1S: manual reset, 1 contact, integrated amplifier

STSnM2S: manual reset, 2 contacts, integrated amplifier

STSnA1S: automatic reset, 1 contact, integrated amplifier

STSnA1: automatic reset, 1 contact, without amplifier

FIS Homologated Startgate: STSnM2S

Startwand STSn-S

A new startgate is supplied with a screwable startwand plus a spare one.

Startwand STSn-FSTAB

Alternatively it is possible to acquire a startwand with integrated spring for more protection of the startwand. This startwand is recommended for Selftimer startgates.

Contacts

There are models with one or two contacts (banana sockets) to which the start cable can be connected. Each contact has its own microswitch in the startgate. For FIS races, separate lines are required for A and B timing device, so you need at least two contacts in the startgate.

Integrated Speech Amplifier

There are startgates with integrated amplifier, in which one can connect a headset and talk with the timing operator via the two-wire start line.

Startwand Reset

The startwand can be reset manually or automatically. Automatic startgates are used mainly for the training and selftimers. Startgates used for races have a manual reset, i.e., after the start, they remain open until the starter closes them before the next start.

Start Poles with Starting Plates SSP

The start poles are driven in the snow and the startgates are attached to them. The starting plates are placed in front of the poles and have a carpet layer on them so each starter has the same kick-off condition.

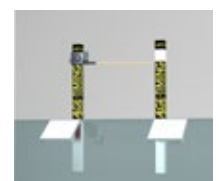



START DEVICES

Startdoor SSD1

The ALGE-TIMING Startdoor SSD1 is made for universal use. It can be used for parallel applications (alpine skiing and snowboarding), cross competitions (snowboarding and freestyle) and team events (alpine or snowboard). The Startdoor SSD1 works absolutely reliable at all weather conditions, and is easy to set up. For transport, they can be folded up and transported conveniently in a compact form.

A battery built into the SSD1-PS control unit guarantees an independent use from mains. The doors are opened electrically. It is possible to open all start doors together or time-delayed. For cross competitions one can mechanically connect the opening flaps of the individual starting doors.

The FIS homologated Startdoor SSD1 has a modular design. A wide range of accessories is available.

Accessories

- control unit SSD1-PS
- controller Timy3 W (delayed control)
- push button 023-02
- startbeep STB1
- start light D-SL85-5RG + G (single-sided)
- start light D-SL85-5RG+G-DS (double-sided)
- headset HS3-2
- speech amplifier SV4-S



START DEVICES

Startdoor SSD1



Parallel race with simultaneous start

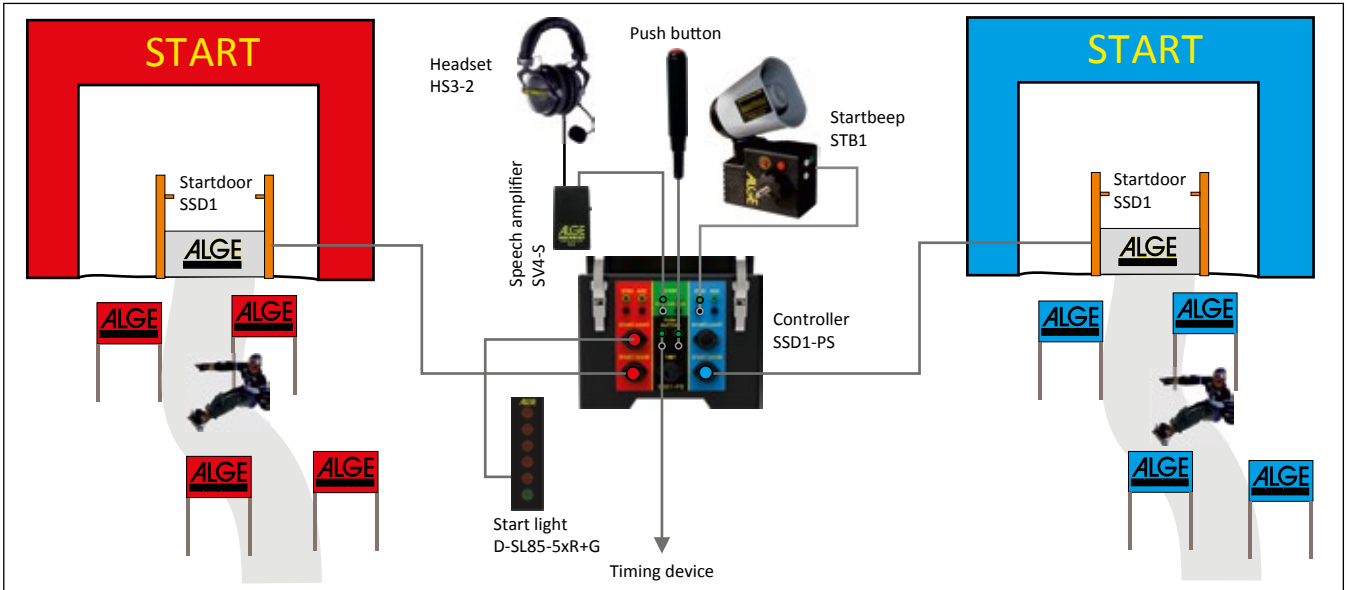

Parallel race with separate start

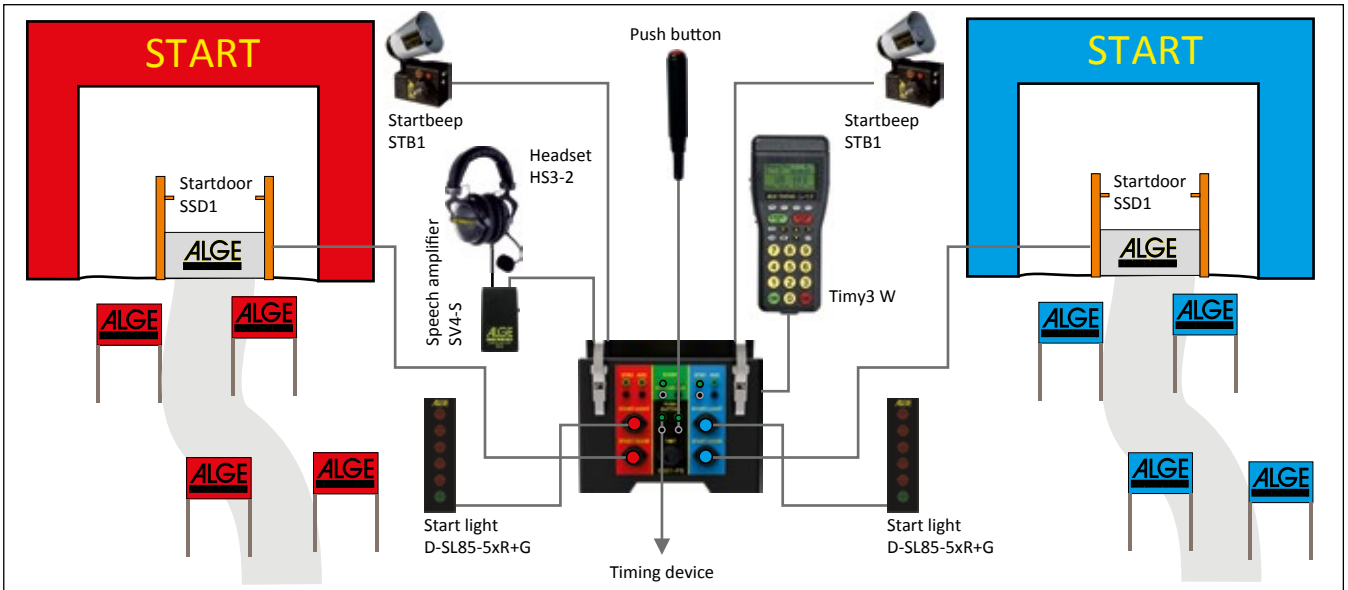

Cross race

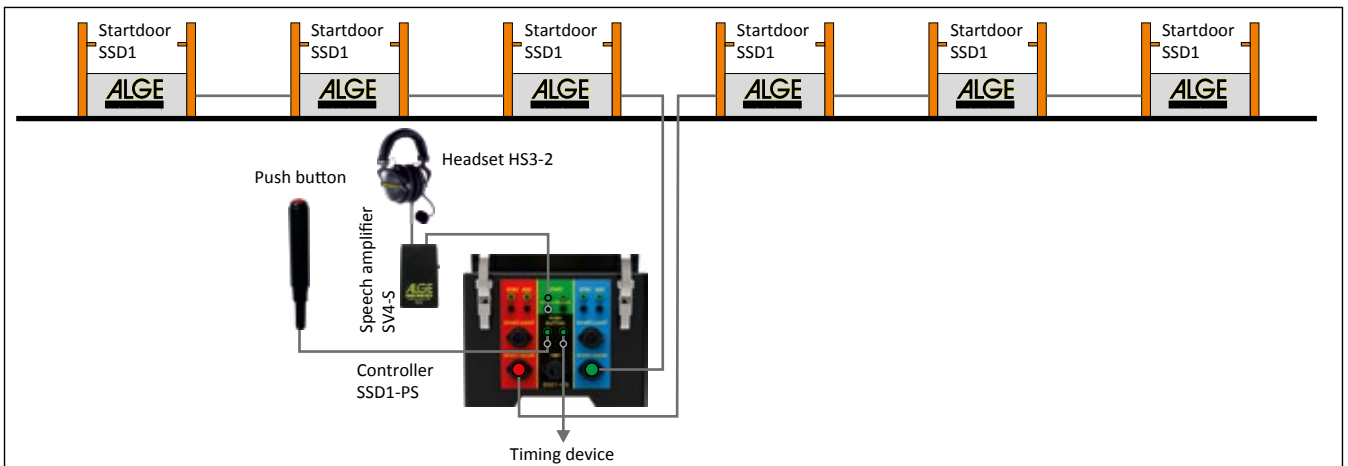



IMPULSE DEVICES

Photocell PR1a and PR1aW

The photocell PR1a is a masterpiece of precision and can be used universally as a reflection photocell, as a transmitter photocell or a receiver photocell.

The photocell emits a modulated light beam in the infrared range, which is monitored by the receiver for interruptions. If the receiver detects an interrupt, it triggers an impulse.

If both, the transmitter and receiver are in the same housing, it is called a reflection photocell. The infrared beam is directed from the transmitter to a reflector. The reflector functions like a mirror and reflects the light beam back to the receiver.

Should longer distances be necessary, one can use a photocell as transmitter-, and another as a receiver photocell.

Photocell PR1a

- impulse accuracy 1/10,000 s
- variety of types:
 - reflection photocell
 - through-beam photocell for long distances
- wide photocell range: over 150 m possible
- variable power supply of the photocell:
 - battery operation
 - power supply from the ALGE-TIMING timing device
 - external power supply from 4 to 18 VDC
- battery status indication with LED (green, yellow, red)
- indicates photocell status with LED (green, yellow, red)
- synchronization of two photocells (main and backup), in order to avoid interference
- setting of the delay time (approx. 20 ms to 2 s/factory setting = 20 ms)
- very long operating time

Photocells PR1aW

The PR1aW photocell has an integrated radio module (2.4 GHz), in addition to all characteristics of the PR1a. The impulse transmission can be carried out by radio and is compatible with the WTN series. 15 different radio-teams and 5 different impulse channels can be set. If required, the PR1aW can also be connected to a timing device via cable.

Additional Functions

- integrated radio module for wireless impulse-transmission
- impulse transmission also possible by cable
- up to 38 hours of operating time with battery

Technical Data

| | |
|-----------------|---|
| Range: | 0.5 to over 25 meters (with reflector) 0 to over 150 meters (transmitter and receiver) |
| Impulse length: | 20 to 2,000 ms can be set |
| Output: | NPN transistor, open collector, active low |
| Dimensions: | approx. 118 x 87 x 44mm |
| Weight: | approx. 0.3 kg |
| Operating time: | approx. 77 hours (PR1a) approx. 38 hours (PR1aW) |



IMPULSE DEVICES

Photocell PR1a and PR1aW



Photocell Sets

Reflection Photocell PR1a-R

Reflection photocell with mounting bracket BBG and 10 m photocell stop cable

Scope of delivery: 1 x PR1a, 1 x PR1a-REF, 2 x BBG, 1 x 001-10



Reflection Photocell PR1a-RT

Reflection photocell, with tripods and 30 m photocell stop cable

Scope of delivery: 1 x PR1a, 1 x PR1a-REF, 2 x TRI128, 1 x 001-30

Through-beam Photocell PR1a-d

Consists of separate transmitter and receiver. The photocell is directed by the transmitter directly at the receiver.

Scope of delivery: 2 x PR1a, 2 x BBG, 1 x 001-10 (10 m)



Through-beam Photocell PR1a-dT

Same as the PR1a-d through-beam photocell, but without the BBG mounting bracket and with tripods and 30 m long photocell stop cable

Scope of delivery: 2 x PR1a, 2 x TRI128, 1 x 001-30 (30 m)

Radio Photocell PR1aW-R (like PR1a-R but with radio)

Scope of delivery: 1 x PR1aW, 1 x PR1a-REF, 2 x BBG

Radio Photocell PR1aW-RT (same as PR1a-RT, but with radio)

Scope of delivery: 1 x PR1aW, 1 x PR1a-Ref, 2 x TRI128

Radio Photocell PR1aW-dT (same as PR1a-dT, but with radio)

Scope of delivery: 1 x PR1aW, 1 x PR1a, 2 x TRI128





IMPULSE DEVICES

Photocell

The RLS3c Triple Photocell

The triple photocell has a range of 2 to 15 m and consists of three photocells, which are built into one housing. It is equipped with a complete transceiver unit, a reflector, 2 tripods and a 30 m cable.

Switchable between the following functions:

Photocell area: Application for athletics; only if all three photocells are triggered an impulse will be generated. This prevents the triggering by arms or legs and the unofficial time of the photocell time corresponds with the “official winner’s time”. This photocell should be used when the time is shown on a display board.

Single photocells: All three photocells operate independently, i.e. if one of the three photocells is triggered, an impulse is generated (e.g. for canine sports agility).



Technical Data

| | |
|-----------------|--|
| Range: | 5 to 15 m (distances under 5 m on request) |
| Output: | NPN transistor, open collector, active low |
| Impulse length: | 20 to 1400 ms can be set |
| Dimensions: | 200 x 370 x 120 mm |
| Weight: | 2 kg (RLS3c with reflector) |



Photocell Adapter LA5

Ideal for photocells which are connected far from the timing device (e.g. intermediate time).

- internal batteries for the photocell supply
- integrated speech amplifier to communicate with the timing operator
- various operating modes, for example, to activate the photocell via a manual push button, when many non-participants pass through the photocell



Mounting Bracket B-P40

Mounting bracket that can be mounted on poles with a diameter of up to 40 mm using screws, in order to mount the photocell or the reflector



Case KS-PR1

For photocells PR1a and PR1aW



Reflectors

Reflector PR1a-REF

Standard reflector for photocells PR1a and PR1aW



Reflector REF-L

Simple reflector, which is used for training



Reflector REF-3

Standard reflector for photocell RLS3c



Reflector REF-C

Reflector for photocell with long distances



Mounting Bracket BBG

Chain holder for fixing the photocells to posts



Mounting Bracket B-S1

Screw-on mounting bracket for mounting the photocell or the reflector



Tripod TRI128

Stable, high-quality tripod with max. height of 128 cm



Tripod TRI-S5

Simple tripod with max. height of 106.5 cm



Cables for Photocells

Start cable with power supply:

002-01, 002-10, 002-30

Stop cable with power supply:

001-01, 001-10, 001-30

Banana cable:

000-01, 000-02, 000-05, 000-10



Synchronization Cable 163-5

To synchronize two photocells PR1a and / or PR1aW



Case KL-RLS3c

For the RLS3c photocell with TRI128 tripods



IMPULSE DEVICES

Accessories

Contact Mat CM40x30 and CM60x43

The contact mats CM40x30 and CM60x43 are impulse devices for timing. It is possible to measure the jump off and the landing on the mat (e.g. the time difference between both).

The contact mats have a normally open contact, i.e. when stepping on it an impulse is triggered. If the jump impulse should be measured, an impulse inverter or a timing device with adjustable impulse input signal (e.g. Timy3) is required.

The contact mat is made from plastic and adhered to an aluminum mat. Their dimensions are 400 x 300 mm or 600 x 430 mm. The complete mats are active except for the edges of about 10 mm.

| | |
|-------------------|--|
| Contact: | closing contact on stepping on the mat - opening contact at jump off |
| Connector: | banana plug (red and black) with 3 m cable |
| Dimensions: | plastic mat: 400 x 300 mm - about 7.5 mm thick aluminum plate: 440 x 340 mm - 3 mm thick plastic mat: 600 x 430 mm – about 7.5 mm thick aluminum plate: 640 x 470 mm – 3 mm thick |
| Plastic mat: | black PVC with 1.6mm support and approx. 4 mm surface, glued to an aluminum plate (3 mm with 4 mounting holes) |
| Voltage: | switch contact area for max. 24 V and 150 mA |
| Protection class: | IP65 |
| Temperature: | -20 °C to +50 °C |

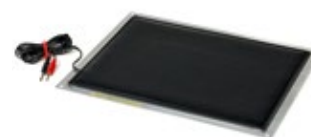

Tape Switch ATS

The tape switch triggers a timing impulse when someone passes over it. For example, if a cyclist passes over the tape switch, the timing device is started or stopped. The tape switch has a closing contact. It has banana plugs with connecting sleeves at the cable. It is available in different lengths:

- tape switch ATS3: 3 m tape switch
- tape switch ATS6: 6 m tape switch
- tape switch ATS7: 7 m tape switch
- tape switch ATS9: 9 m tape switch

Other tape switch lengths on request.



Foot Operated Switch FKS

In training, one foot is placed on the contact feather of the foot-operated switch. When the foot leaves the contact feather, the timing is triggered by the internal NO contact. The foot switch is very heavy, so that it does not slip.

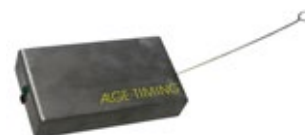

Potential-free Impulse Transformer 029

The adapter 029 is connected to the ALGE-TIMING timing device. It is possible to connect an impulse device (e.g. photocell). You can alternatively use this input contact as NOC or NCC. It is ideal to connect impulse devices from other companies. The adapter 029 is powered by an internal 9 V battery.



IMPULSE DEVICES

Accessories



Manual Push Button 023-XX

The manual push button for start and stop impulses is available in two models: with 2 m cable length as 023-02 or with 10 m cable length as 023-10, each with banana plugs.



FLASH XL

The starting flash light FLASH XL is an optical start device that can additionally be used with acoustic starting devices such as a start gun. It is mainly used for running or swimming competitions. The FLASH XL is triggered by an external impulse generator, for example via a start gun or a manual push button. If another impulse occurs within five seconds, it will show 5 flashes as false start signal.

The FLASH XL has 80 LEDs (light-emitting diodes), which are installed in a plastic housing. These LEDs are extra bright so that the flash is visible even in sunlight. There are different connection sockets for the start impulse. The power is supplied by internal batteries (4 x AA) or directly from the timing device.



Start-stop Switch 300-01

This device is used to change the input impulse for the timing device. You can make a start impulse, stop impulse or deactivate the impulse.





CABLES & ADAPTERS

A LGE-TIMING devices can be equipped with a wide range of suitable accessories, which are used to support the functions and considerably extend the range of applications.



Headset HS3-2

Headset with double-sided earphones and one microphone; recommended for outdoor and/or for high surrounding sound level



GPS Receiver GPS-A

GPS receiver for precise synchronization of the timing devices (e.g. for the Timy3 or the ASC3 Startclock)



Headset HS2-1

Headset with single-sided earphones and one microphone; recommended for outdoor and/or for high surrounding sound level



Adapter USB RS232I

The USB-RS232I is an adapter which takes care of optimal isolation between the timing device and the PC. It is used when disturbing noise is heard in the speech connection, when a PC is connected. In addition, the adapter allows a timing device with RS232 interface to connect to a USB interface of the PC.



Speech Amplifier SV4-S

With two connections for two-core connection wire (banana plugs), connection for headset, volume control and switch and/or push button for microphone



Adapter USB-WTN

The USB-WTN is an universal adapter with mini-USB cable, which acts as interface converter for many ALGE-TIMING devices. Originally, the adapter was developed in order to connect the WTN radio system to the PC via a USB cable



Speech Amplifier SV4/SM

With connection for two-core connection wire (banana plugs), connection for headset, connection for start microphone, volume control and switch and/or push button for microphone



Multichannel MC9

Channel expansion for the Timy3 with 9 pairs of banana jacks (impulse channel 0, 1, 2, 3, 4, 5, 6, 7 and 8) and RS232/RS485 socket



Printer P5

The P5 is a fast and quiet thermal printer with a wide temperature range (-20 °C to +50 °C). It is available with different plugs, e.g. for TimeManager, Timy3 W or Startclock ASC3. The power is supplied by the timing device or the PS12A.



Timy Docking Station TIDO

Extension for the Timy3 with integrated speech amplifier and the following connections:

- 4 x DIN sockets for photocells
- 1 x multi-port socket
- 2 x DIN socket for RS232
- 1 x DIN socket for the headset
- 9 x pairs of banana sockets (impulse channel 0, 1, 2, 3, 4, 5, 6, 7 and 8)



Power Supply

The range includes various mains chargers, suitable for every timing devices, for example:

- PS12 power supply with DIN plug
- PS12A power supply with DC plug



Cables

A wide selection of cables for different use in various lengths is available for ALGE-TIMING devices.



Cable Reels

Various cable reels with different cable lengths are available for the ALGE-TIMING devices, for example for the start line or data cable for display boards with two-wire steel cable (extra strong military quality).

- KT150: 150 m field telephone line
- KT300: 300 m field telephone line
- KT500: 500 m field telephone line



Tripods

Tripods of various heights and with different load carrying capacities

- tripod TRIMAN: professional tripod for camera (maximum height 2.4 m)
- tripod TRI128: professional tripod (maximum height 1.28 m, see picture)
- tripod TRI-S5: simple tripod (maximum height 1.065 m)



Case KL

The case KL is used for transporting timing devices and accessories. The interior life of the cases can be equipped with many different foam inserts.



Timing Backpack ATBP

The ATBP is a high-quality backpack with special compartments for storing the timing accessories. It is ideal to transport the equipment, for example, on the ski slope. It has a well padded back section and straps.



Carrying Bag for Display Boards

Carrying Bags for GAZ5 and D-LINE display boards

- carrying Bag GTT15: for display boards with a digit height of 15 cm and a 6-digit housing
- carrying bag GTT25: for display boards with a digit height of 25 cm and 6-digit housing



RADIO DEVICES

Teledata TED400

The ALGE-TIMING Teledata TED technology makes radio transmission absolutely safe. The start and stop impulses are converted by the radio transmitter TED-TX into a data packet, supplemented with a security code and sent to the radio receiver TED-RX. After checking the safety code, the receiver provides the impulse with a precise and reproducible delay of 0.1 seconds to the timing device.

The Safety Package of the Radio System ALGE-TIMING Teledata TED

A special software in the TED-RX receiver sorts out incorrect protocols and by this, avoids false impulses. The radio range is up to five kilometers. It is possible to set up as many as 16 different addresses. A system cannot receive impulses from a differently addressed system, for example, if different TED systems are used in the same area.

The Teledata TED400 guarantees data transmission with high security. The data are transmitted with a security code from the transmitter TED-TX to the receiver TED-RX, which supplies the data packet to the receiver device. In addition, the last data record is always stored in the transmitter TED-TX.

Impulse Transmission

A timing impulse is transmitted wireless from an impulse device (e.g. photocell) by the TED-TX to the TED-RX that is connected to the timing device.

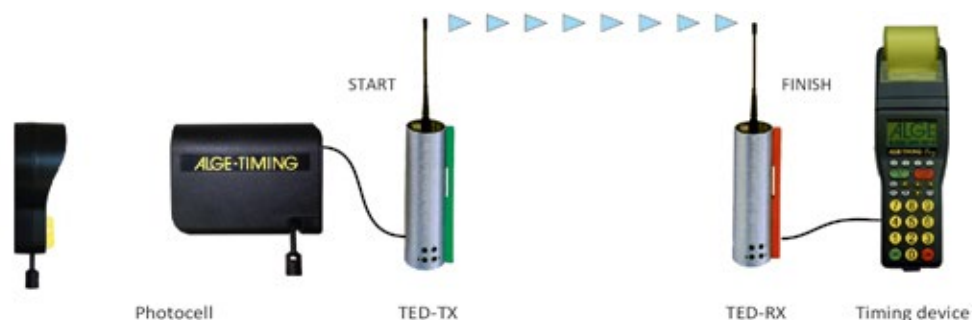

ALGE Impulse Device

- photocell PR1a
- photocell RLS3c
- start microphone SM8
- startclock ASC2/3
- startbeep STB1
- tape switch ATS
- touchpad TP
- manual push button
- closing contact

ALGE impulse receiver

- TdC8001
- TIMER S4
- Timy
- Photo finish OPTIc2n/3
- Startclock ASC2/3

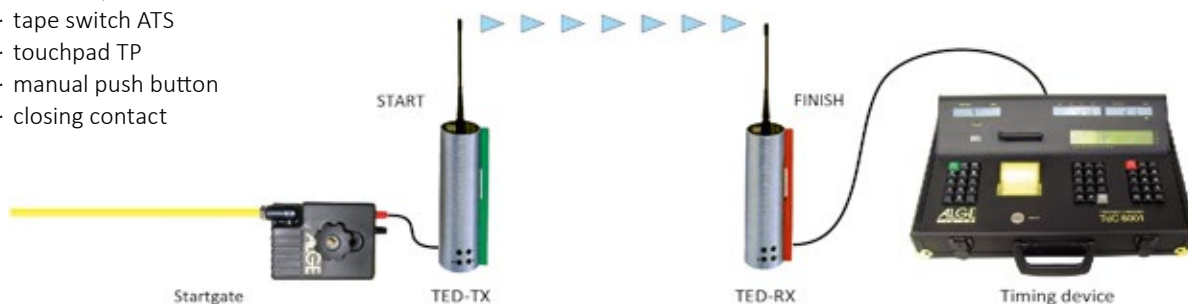

RADIO DEVICES

Teledata TED400



The Standard Version

The standard version of the TED-RX can receive two different timing channels. With the addition of RX-C10, up to 10 different channels are possible; with the corresponding software in the timing device, 9 channels.

Data Transmission

Each data set from an ALGE-TIMING timing device is transferred once.

Each 1/10 of a second, one data set can be sent:

- from the timer to the display board
- from the timer to the printer
- from the Timy on a soccer display board

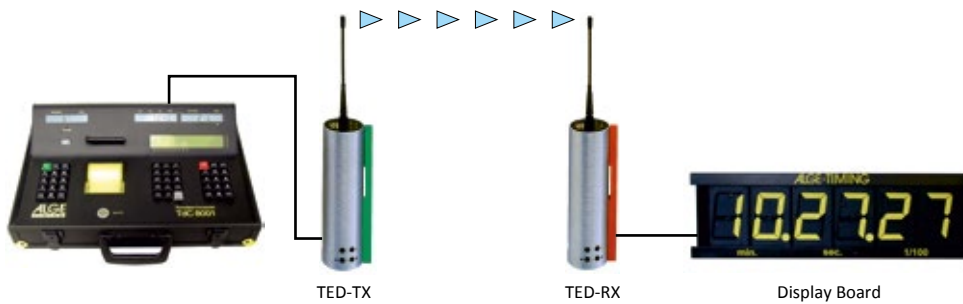

Free Data Transmission

Any kind of data format can be transferred. A data set is sent every 1/10 second.

Fields of Application:

- timing device to PC
- PC to PC
- PC to display board

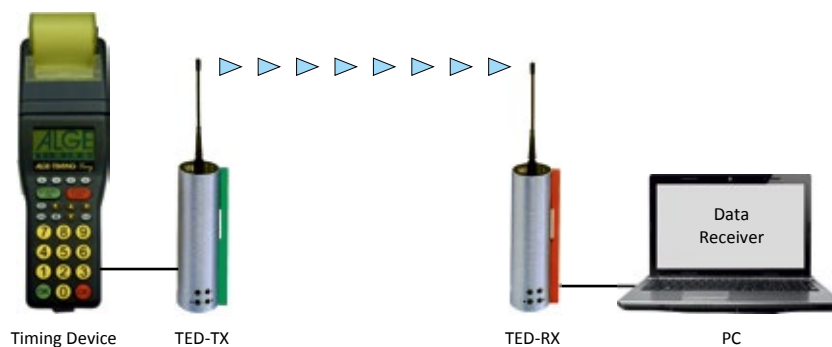



RADIO DEVICES

Teledata TED400

Technical Data

Transmission performance: 400 mW
 Range: up to approx. 5 km
 Frequency: 433.800 MHz (standard frequency)
 alternatively, upon request: 434.650 MHz, 433.200 MHz, 433.650 MHz
 Interfaces: TED-TX400: RS232 (input)
 TED-RX400: RS232 (output)
 Power consumption: TED-TX400: 270 hours at one impulse per minute
 TED-RX400: 54 hours at one impulse per minute
 Antenna: short, robust, flexible, BNC connector
 Connections: compatible with all ALGE-TIMING products and almost all other products
 · banana socket for data and start impulses
 · DIN socket with connection for start, stop impulse, data and external power supply
 Input signal: closing contact, active low, at least 10 ms
 Output signal: transistor, open collector, active low, 100 ms
 LED: for battery indication (TED-TX and TED-RX), additionally for field strength display in the TED-RX
 Loudspeakers: in the TED-RX for field strength information and for interference indication, warning tone for weak batteries
 Power supply: internal: 6 x AA alkaline batteries or 6 x AA NiMH rechargeable batteries
 external: charger PS12 or timing device
 Operating temperature: -20 °C to +50 °C
 Dimensions: 198 x 72 x 72 mm (without antenna)
 Fastening: velcro fastening for mounting on a pole, thread for tripod
 Accessories:
 · case with foam insert
 · battery pack with 6 x NiMH rechargeable batteries for TED
 · LG6AA Charger for NiMH rechargeable batteries
 · channel expansion RX-C10
 · bracket for mounting with photocell and tripod or mounting bracket



Attention

The laws for radio systems are very different worldwide. Please check the local laws before commissioning a radio system. Depending on the country, such a radio system may be prohibited or subject to registration.

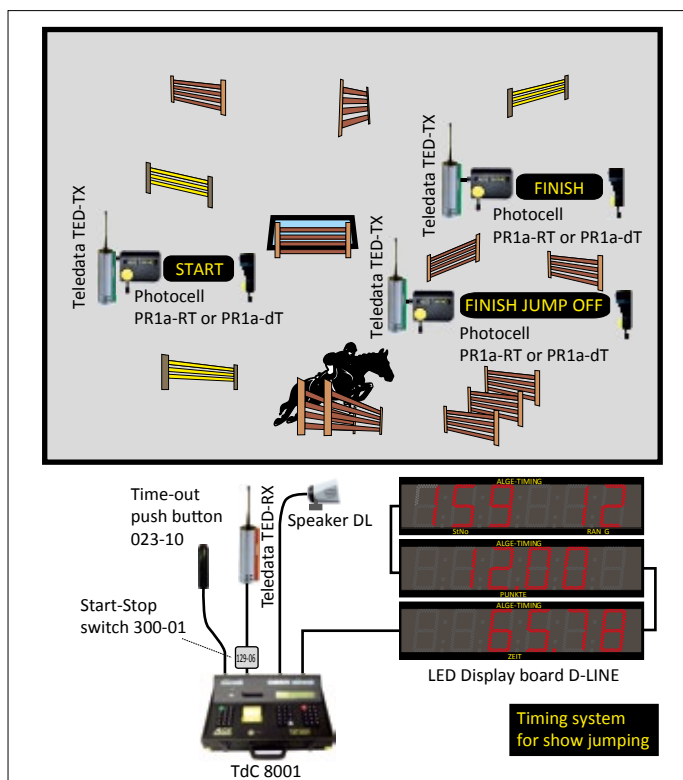
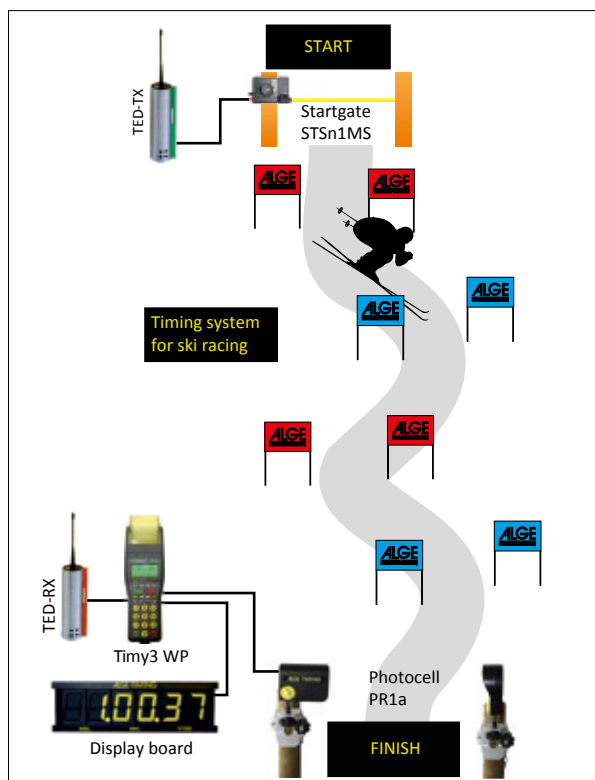

RADIO DEVICES

Wireless Timing Network WTN



The “Wireless Timing Network WTN” is a radio network for timing, in which different timing devices communicate with each other via radio, in the 2.4 GHz band. The constant dialogue of the devices ensures a high degree of security, i.e. if a device can no longer be found in the network, this is reported immediately.

The WTN allows for a wireless communication of the timing device with peripheral devices such as photocells, display boards or the evaluation PC. The photocell, for example, sends the impulse by radio to the timing device, which transmits the data by radio to the display board and to the PC with evaluation software.

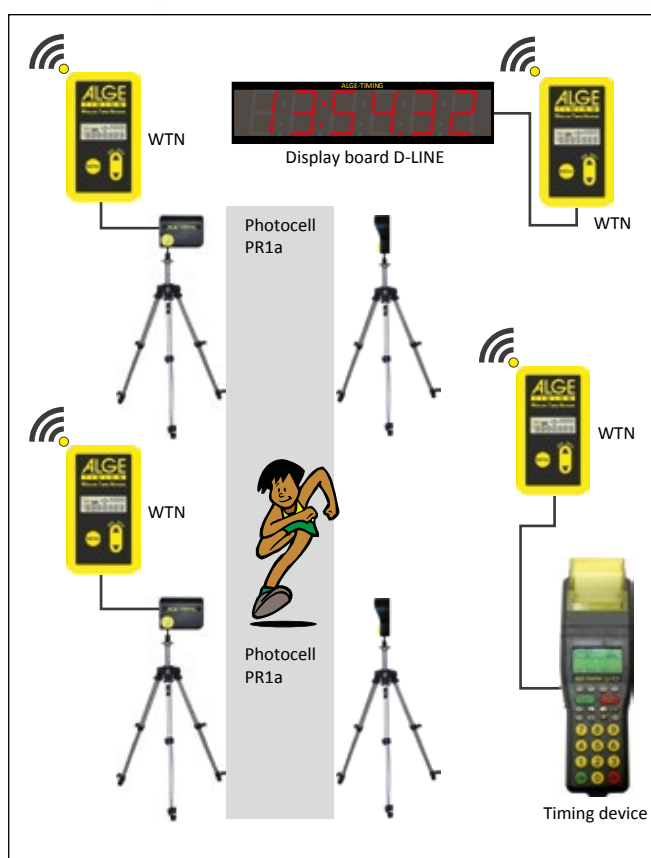

The bidirectional radio network WTN replaces the cables for the timing with 15 adjustable teams, in the 2.4 GHz band. All devices communicate with each other in the same network and simultaneously transmit data and impulses during indoor and outdoor use.

The universal genius WTN can be connected to almost any timing device, impulse device or display board from ALGE-TIMING. Perfectly suited even for data transfer to a PC.

This variety of applications is supported by a LCD display with keyboard for setting the required application purpose, the universal connections (timing channels, RS232, RS485) and internal batteries.

During development of this unique wireless timing network ALGE-TIMING paid particular attention to ease of use, reliability and robust design.

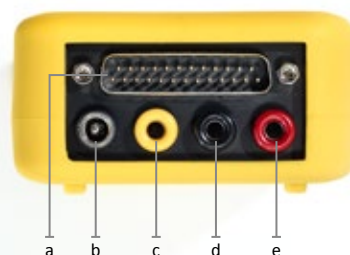

- a - ALGE-TIMING Multiport
- b - DC Power Supply
- c - banana socket yellow: data output or data input for GAZ or D-LINE
- d - banana socket: ground
- e - banana socket: timing channel - input



RADIO DEVICES

Wireless Timing Network WTN

Timy3 with integrated Wireless Timing Network WTN

The integrated radio modem WTN makes it possible to connect the Timy3 by radio with all devices of the WTN series in a network. For example, one can receive start impulses, intermediate time- and finish impulses, control a display board, and send data to a PC with an evaluation program.

Technical Data of the WTN

Frequency: 2.4 GHz band, 15 adjustable teams
 Transmission performance: 10 mW - 100 mW (adjustable)
 Time measuring channels: 5 different time measuring channels adjustable C0 (start), C1 (finish), C2, C3, C4
 Range: approx. 350 m with clear view, each WTN device serves as a repeater. Thus, the range can be extended.
 Display board: RS232 interface - 2,400 to 19,200 baud
 interface: yellow/black banana sockets
 RS232 interface: RS232 interface - 2,400 to 115,200 baud via multi-port connector
 Battery: 3 x AA battery (alkaline or NiMH rechargeable battery)
 Housing: plastic housing with elastic yellow rubber jacket to protect the unit in all weather conditions

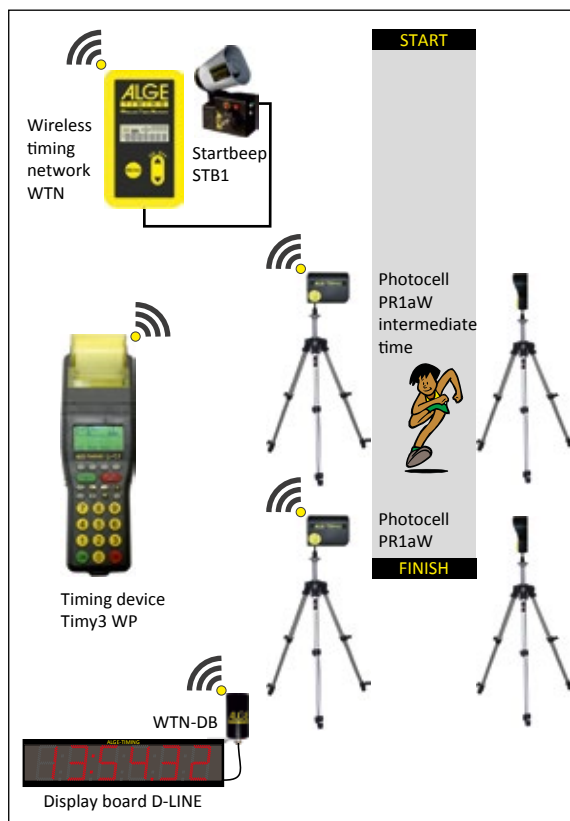

Photocell PR1aW

The PR1aW has an integrated WTN radio module. The impulse can be transmitted by radio and it is compatible with the complete WTN series. If required, the PR1aW can also be connected to the timing device via cable.

Wireless Timing Network manual push button WTN-PB

The WTN-PB is a manual push button with integrated WTN module. The team and the time measuring channel are adjustable.

Time measuring channels: C0 (start channel), C1 (destination channel), C2, C3 or C4
 LED: 2 x LED for status display (e.g. battery status)
 Power supply: internal C-battery (for approx. 50 hours)



Area of Use

- impulse transmission
- timing during show jumping
- training in the stadium or in the hall
- display board control for D-LINE or GAZ
- data transfer to PC

Accessories

- holder with Velcro strip SPB1
- cable 280-03: to the Timy or TdC8000/8001 (25-pin D-Sub)
- cable 283-02: to the PC (25-pin to 9-pin - D-Sub)
- cable 284-02: to the display board (25-pin D-Sub on Amphenol - 4-pin)



Wireless Timing Network WTN-DB for Scoreboards

The WTN-DB receives the data from the display panel from the WTN network and transmits it via the serial interface. The power supply and data transmission takes place through the display panel via the 4-pin Amphenol connector.

PHOTO FINISH

OPTic3



The photo finish system OPTic3 takes over the technical leadership in the photo finish market. It has a recording rate of up to 30,000 lines per second (fps), with up to 2016 vertical pixels. This makes it the perfect timing device for every kind of sport, which must rely on good photo finish images for precise results.

Features such as 2-D images, autofocus, and automatic iris control make the system user-friendly. The VoIP enables communication with the starter, without the timing operator having to use a headset.



Standard Network

A simple data connection with almost every PC is possible via Ethernet or WLAN.

Autofocus

With the motor zoom of ALGE-TIMNG, one can access practical functions like autofocus and automatic iris adjustment.

LiveView

The camera image can be displayed and set via WLAN, on a mobile phone or tablet. Through this, one can adjust an OP-

Tic3 camera which is set up far away from the PC and has no motor zoom, in a simple, fast and accurate manner.

2-D Image Adjustment

With the new 2-D image setting (max. 2,016 x 360 pixels), the camera can be aligned with the finish line, in the shortest possible time

High-speed Camera with 2-D Images

With its 100 Hz 2-D time-measuring full-screen mode, the OPTic3 is ideal for

sports such as swimming and rowing. Since the OPTic3 has a built-in timing device, exactly synchronized 100 images per second can be guaranteed.

PC Software

The modern, powerful OPTic3 NET software enables a quick and easy evaluation of the photo finish picture. The following operating systems are supported: Windows 7/Windows 8/Windows 10





PHOTO FINISH

OPTIc3

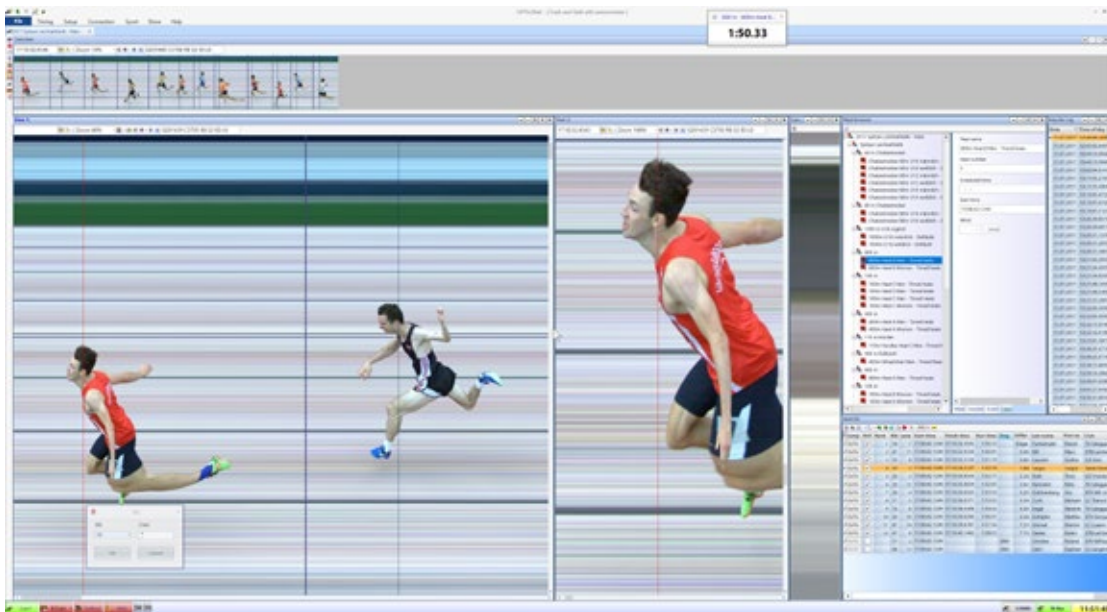

The OPTIc3 photo finish system is available in two versions:

OPTIc3 Basic System

Photo finish system with a recording rate of 3,000 lines per second and 1,360 pixels, for the small budget. The features listed in the OPTIc3-PRO are not included in the basic system, but one may upgrade it with all the features of the OPTIc3-PRO.

OPTIc3-PRO

Professional photo finish system that leaves nothing to be desired. The following additional features are integrated:

- high-speed recording: up to 30,000 fps
- high resolution: 2,016 pixels vertical resolution (48 % more than OPTIc2)
- extremLuX: various technologies for image improvement, under bad light conditions
- motion detection: automatic recording with motion detection
- integrated WTN: wireless impulse- and data-transmission
- high-speed camera: It is possible to record 100 images per second in 2-D mode, with 1,024 x 768 or 360 x 2,016 pixels. The proven IDCam software is available for this function
- VoIP: Voice-over IP allows communication with the starter without the need for the PC operator to use a headset.



PHOTO FINISH OPTIc3

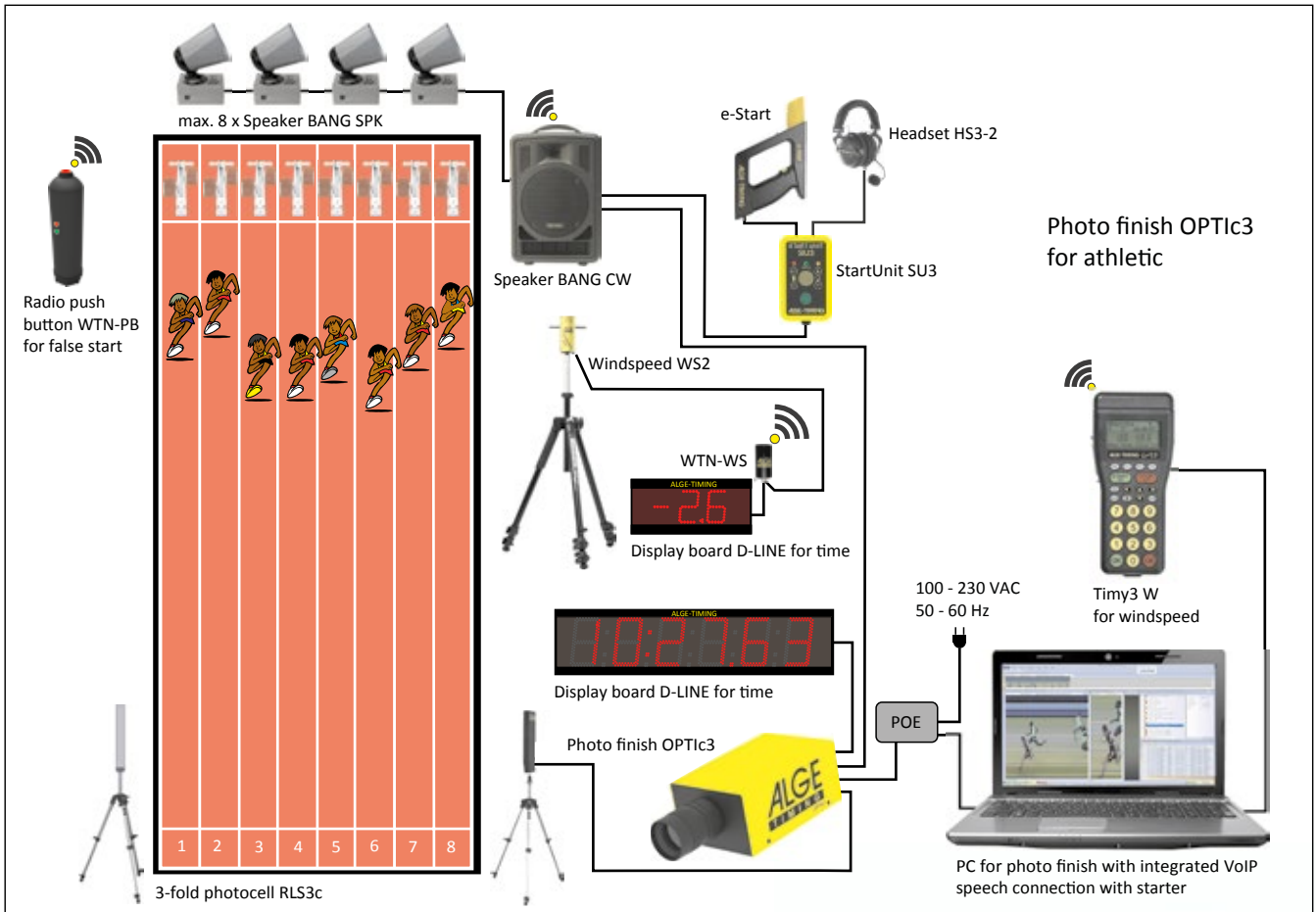



PHOTO FINISH

OPTIC3



Technical Data

Vertical resolution: up to 2,016 pixels
 Scan rate (fps): up to 30,000 frames per second
 Recording time: unlimited, depending on PC hardware
 Timing: temperature-compensated quartz oscillator TCXO,
 +/- 0.06 ppm at 25 °C (0.0002 s/h)
 Power supply: PoE for 9 - 13.4 VDC
 Temperature range: -20 °C - 50 °C



Connections

- 2 x start input (banana socket)
- 1 x finish input (banana socket)
- 2 x channel input (3 input channels/DIN socket)
- 1 x display board RS232 (banana socket)
- 1 x display board RS485 (banana socket)
- 1 x motor zoom
- 1 x gear head
- 2 x USB (e.g. for WLAN)
- 1 x RJ45 (Gigabit Ethernet)
- 1 x power supply (9 - 13.4 VDC)

Type of Sport

- athletics
- cycling
- horse racing
- dog racing
- rowing
- canoeing
- motor sports
- inline skating
- cross-country
- biathlon
- ski cross
- snowboard cross
- speed skating
- short track
- backup for any sport



PHOTO FINISH

OPTIc3 Accessories



The OPTIc3 photo finish system can be expanded as required with practical accessories or can be equipped for specific requirements of sporting events. In addition to the standard accessories, there are also unique special solutions, which can be customized.

Zoom Lens Z75

manual zoom lens
C-Mount $\frac{3}{8}$ ", 12.5 - 75 mm / F1.2



TRIMAN Tripod

standard TRIMAN tripod with a maximum height of 2.4 m



Motor-Zoom MZ75C

focus-, zoom- and brightness-control from the PC
C-Mount $\frac{3}{8}$ ", 12.5 - 75 mm / F1.2



Battery Backup BB1

battery power supply for camera (integrated 12 VDC battery with power supply)



Motor-Zoom MZ160-R

focus-, zoom- and brightness-control from the PC.
C-Mount $\frac{3}{8}$ ", 16 - 160 mm / F1.8



Cable Reel KT-RJ45G90

cable reel with 90 m CAT6 Ethernet cable for the OPTIc3 (the camera can also be powered by the POE)



Wide Angle Lens L8.5

C-Mount $\frac{3}{8}$ ", 8.5 mm / F1.3



Transport Case KL-OPTIc3

case with foam insert for protective storage and transportation of an OPTIc3 system



Tripod STATIV6

tripod with a maximum height of 3.66 m



Ethernet Cable K-RJ45G03

CAT6 patch cable with 3 m



Radial Polarization Filter PF55

(on request) polarization filters available, for attenuating reflections (e.g. from the water)



Ethernet Cable K-RJ45G10

CAT6 patch cable with 10 m



Weather Protection Cover WPC3-75

for OPTIc3 camera with the lenses Z75, MZ75C and L8.5



Power over Ethernet POE

for feeding the OPTIc3 camera via the Ethernet cable (POE is included with the OPTIc3 camera - supply 90 - 240 VDC)



Gear Head 410

three-dimensional, mechanical gear head, for the exact adjustment of the camera to the finish line



Gigabit Switch POE

Gigabit switch with 8 RJ45 sockets and integrated power over Ethernet



Gear Head 410-E3

electronically controlled by the PC three-dimensional geared motor (no further wiring required)





MONITORING OF THE FINISH LINE

IDCam

The IDCam is a reliable and simple way to monitor the finish line. When an athlete crosses the finish line a series of high resolution pictures is taken and stored on the PC with the time of the day for each image.

The IDCam can be connected to an ALGE-TIMING timing device. The photocell at the finish line starts the recording of the images by the IDCam. The images are automatically sorted with the correct ID-number if the number is entered in the timing device in advance.

The recorded images help determine the arrival order of the athletes at the finish line, correct the missing finish line arrivals and add the bib numbers, which can be read from the pictures.

The IDCam is the ideal addition to any ALGE-TIMING timing devices.

- Number of images: up to 30 frames per second
- Picture resolution: 3072 x 1728 px (5 MP)
- Connections: camera IDCam to PC: Ethernet CAT5 cable up to 100 m length
timing device with PC: RS232 or USB
- Recording time: endless, depending on the capacity of the PC's hard disk
- PC operating system: Windows Vista, 7, 8, 10
- Power supply: POE: 90 - 280 VAC

Scope of Delivery

- 5 Megapixel Network Camera
- zoom lens 4 - 8 mm for camera
- 3 m CAT5 cable K-RJ45G03
- 20 m CAT5 cable K-RJ45G20
- POE Power supply
- PC Software

Optional Accessories

- weather Protection WP-IDCam
- tripod TRI128 or TRIMAN
- ball joint 482
- cable reel KT-RJ45G90

Supported Timers

- TdC8001, TdC8000, and TdC4000
- Timy3, Timy2 and Timy
- Comet
- Timer S4
- Photo Finish OPTIc2 and OPTIc3
- OPTIc3 in 2-D mode
- manual recording mode via PC keyboard



IDCam with lens



CAT5 cable with 20 m and 3 m



POE



weather Protection WP-IDCam



tripod TRI128



ball joint 482

MONITORING OF THE FINISH LINE

IDCam



Setup

IDCam with 20 m long Ethernet cable (can be up to 100 m long) with power supply POE. Connect the POE to the PC using a 3 m Ethernet cable. Connect the ALGE-TIMING timing device to the PC via RS232 or USB cable.

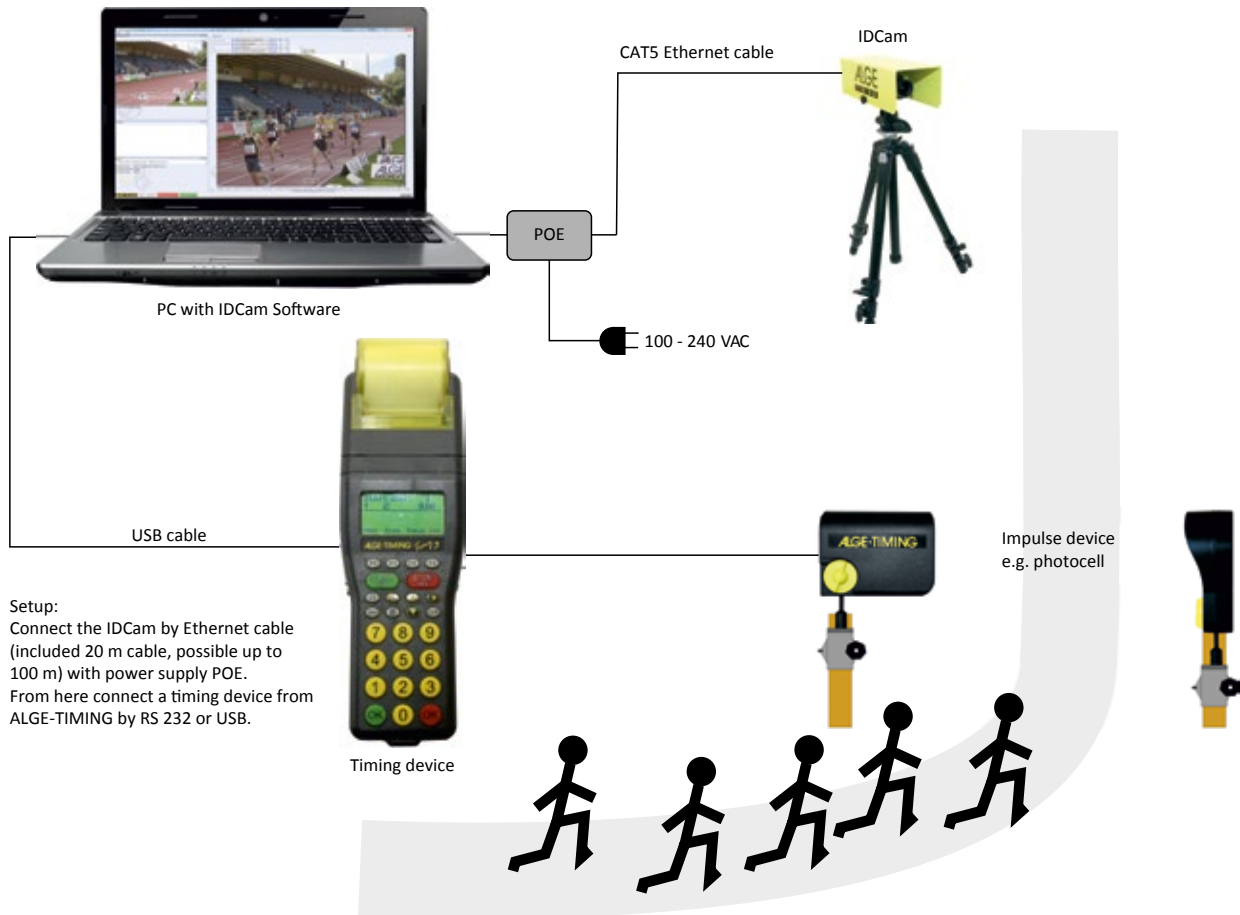

Setup:
Connect the IDCam by Ethernet cable (included 20 m cable, possible up to 100 m) with power supply POE.
From here connect a timing device from ALGE-TIMING by RS 232 or USB.



MONITORING OF THE FINISH LINE

IDCam

Example of cooperation between IDCam and Photo Finish OPTic3 in cycling

The IDCam is the ideal complementary device to the photo finish OPTic3, because it controls the finish line recording, and helps determine the bib numbers, from the finish line arrivals, in case these were not readable in the photo finish picture.

The example of a cycling finish arrival shows that together with IDCam and ALGE-TIMING photo finish

OPTic3, you have the ideal tool for evaluating the finish quickly and independently of the finish arrival judge.

The IDCam can be controlled via the OPTic3.NET software running on the same PC as the photo finish software OPTic3.NET, but it can also be installed on another PC on the same network.

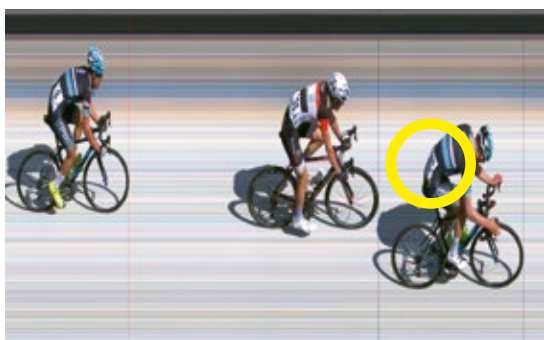

Photo finish image from OPTic3-PRO



Picture of a competitors reaching the finish line, by the IDCam (complete picture)

The cyclist with ID-number 10 can not be identified in the photo finish picture. In the picture taken by the IDCam, the starting number 10 is, however, clearly recognizable (see image below).



Enlarged picture of competitors reaching the finish line, by the IDCam

MONITORING OF THE FINISH LINE

IDCam



Example of cooperation between IDCam and Photo Finish OPTic3 in athletics

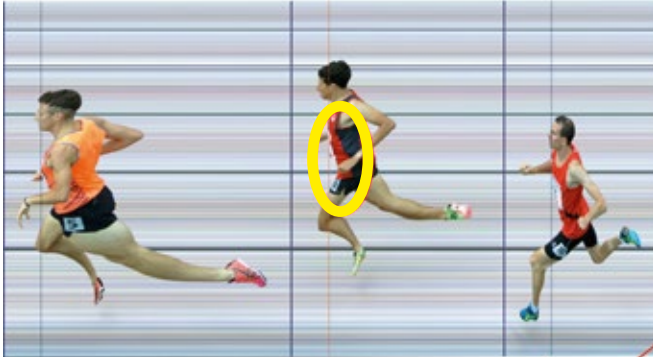

Photo Finish Picture of OPTic3-PRO



Photo of the finish line by the IDCam (complete picture)

ID-number 180 and side number 6 is not readable on the photo finish picture, but in the picture of the ID-Cam the ID-number 180 and side number 6 is clear visible (see image below).



Enlarged photo of the finish line by the IDCam



DISPLAY BOARD

GAZ5

With the GAZ5 display board, it is possible to read numeric data even in the distance and in direct sunlight. The ALGE-TIMING display boards with 15 or 25 cm high digits are robust and also proven for outdoor use.



The new generation GAZ5 is characterized by the following features and advantages

- direct control by all ALGE-TIMING timing devices via a two-wire data cable or radio
- manual entry with the terminal ALGE-Timing Timy3 (e.g. points or ratings)
- counting system in conjunction with ALGE timing Timy3 (e.g. person counting via turnstile)
- universal use due to the control via RS232 or RS485 interface (e.g. from the PC as an electronic scale)
- The display board can be used during charging (model with rechargeable battery).
- switch for three different display configurations in timing:
 - start number and rank
 - minutes, seconds, hundredths of a second
 - hours, minutes, seconds
- selector switch for addressing and special functions
- Two displays can be combined to show bib number, rank, and time.
- Up to 10 lines can be linked together to a ranking board.
- Integrated electronic clock enables autonomous use as a daytime or stopwatch.
- countdown clock to the display of game times (entry of the game time and time-out with the push button)
- optimal readability even in direct sunlight
- long life due to the use of bistable seven segment displays in a robust coated aluminum housing with plexiglass front
- best operational safety, thanks to CMOS technology and quality of ALGE-TIMING
- low power consumption: energy is needed only at the moment of the information exchange
- there are three variants of the power supply:
 - with 11 to 20 V DC voltage (e.g. car battery)
 - from power mains with integrated power supply PS5
 - internal battery (or mains) with integrated power-pack PP5

DISPLAY BOARD

GAZ5

00:00:00

Technical Data

| | |
|-----------------------------------|---|
| Electronics: | μ-process technology in CMOS technology with watchdog |
| Indicators: | bistable seven segment displays, yellow on black ground (best reading contrast), low power consumption, great operating safety |
| Housing: | aluminum housing, plastic-coated (black) with a pane of plexiglass, suitable for outdoor use, 4 hanging loops |
| Interface: | RS232 and RS485 |
| Temperature range of application: | -25 °C to +50 °C |
| Power supply: | <ul style="list-style-type: none"> · direct supply: 11 to 20 V DC/2.5 A · power supply PS5: integrated power supply, 90 - 132 VAC and 187 - 264 VAC/50 Hz or 60 Hz · power-pack PP5: integrated rechargeable battery (NiMh battery) with mains charger, 90 - 132 VAC and 187 - 264 VAC/50 Hz or 60 Hz, charging time: approx. 14 hours |

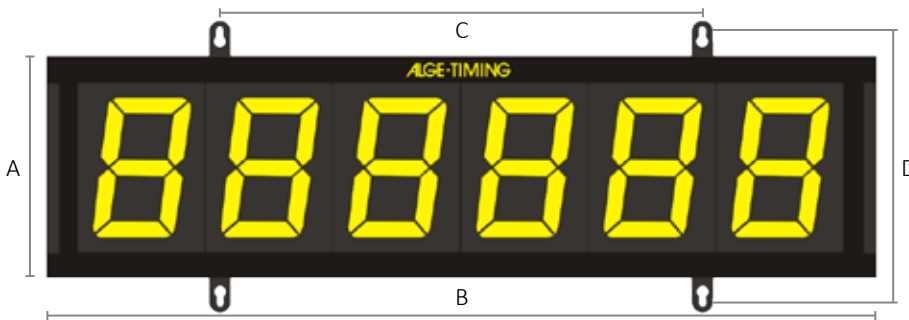

| Standard models | Weight | A | B | C | D | Depth | Max. reading distance * | Operating time ** |
|-----------------|--------|--------|----------|----------|--------|--------|-------------------------|-------------------|
| GAZ5 515 | 12 kg | 290 mm | 956 mm | 556 mm | 352 mm | 100 mm | 75 m | 60 h |
| GAZ5 615 | 13 kg | 290 mm | 956 mm | 556 mm | 352 mm | 100 mm | 75 m | 60 h |
| GAZ5 525 | 21 kg | 393 mm | 1.493 mm | 1.093 mm | 455 mm | 100 mm | 125 m | 20 h |
| GAZ5 625 | 22 kg | 393 mm | 1.493 mm | 1.093 mm | 455 mm | 100 mm | 125 m | 20 h |
| GAZ5 545 | 45 kg | 664 mm | 2.490 mm | 2.090 mm | 726 mm | 120 mm | 225 m | 11 h |
| GAZ5 645 | 48 kg | 664 mm | 2.490 mm | 2.090 mm | 726 mm | 120 mm | 225 m | 11 h |

Standard configuration - other configurations available upon request

* max. reading distance according to DIN 1450

** operating duration: operation of the clock in second mode (power-pack PP5 at 20 °C)



Example of the Order Code

GAZ5 645 PP5

| | |
|--|--|
| | power supply (e.g. PP5 or PS5) |
| | · PP5 power-pack (integrated mains charger and rechargeable battery) |
| | · PS5 power supply (built-in power supply) |
| | digit heights |
| | number of digits |
| | scoreboard type |



DISPLAY BOARD

D-LINE

The Multi-functional LED Display Board

The ALGE-TIMING D-LINE is an universally usable, numeric LED display board which can be directly controlled by ALGE-TIMING timing devices and can also display data from other devices via the RS232 interface.

The integrated clock can be used in the stopwatch or count-down mode or to display the exact time of day. If it is equipped with the option DCF, GPS and/or temperature photocell, the temperature can be displayed in addition to the exact time of day, even if no timing device is connected.

The difference between in- and outdoor-models is mainly with the used LEDs. In the case of outdoor models, much lighter LEDs are used, which make the displayed information readable even in direct sunlight.

By default, the display board has six digits, but other configurations are possible.

Advantages of the LED display board against other display systems (electromagnetic display boards) are the low-cost acquisition and low weight. The brightness of the LED display board comes into play when the display board is placed in dark areas.

The power can be supplied directly from the mains (100 - 240 VAC) or from an external 12 V battery (e.g. car battery).

Display boards can display the following numeric data:

- times
- bib numbers
- rank
- speed
- widths
- heights
- remarks
- points
- weights
- prices
- temperatures
- departure times
- stock Quotes
- etc.

Possible Extensions:

- DCF radio receiver
- GPS radio receiver
- temperature sensor (max. two sensors)
- humidity sensor
- Ethernet connection (for time synchronization via Ethernet)



Technical Data

- LED seven-segment digits with three dots between digits
- internal clock
- internal push button
- RS232 and RS485 interface
- connections:
 - banana socket for data (RS232)
 - banana socket for data (RS485)
 - banana socket for external manual push button
 - amphenol socket (four-pin) for data or power supply (12 VDC)
- integrated power supply (100 - 240 VAC, 50 - 60 Hz)
- fastening:
 - 4 hangers
 - 3/4" thread for tripod
- black aluminum case with red front plexiglass
- operating temperature: -20 °C to +60 °C

DISPLAY BOARD

D-LINE



| | Digit number | Figure height | Height | Width | Depth | Hanging loops-spacing | Weight | Power consumption | Maximum reading distance |
|-----------------------|--------------|---------------|----------|----------|-------|-----------------------|--------|-------------------|--------------------------|
| Indoor models | | | | | | | | | |
| D-LINE57-I-6-E0 | 6 | 57 mm | 130 mm | 500 mm | 60 mm | 200 mm | 2 kg | 13 W | 28 m |
| D-LINE100-I-6-E0 | 6 | 100 mm | 180 mm | 800 mm | 60 mm | 500 mm | 4 kg | 13 W | 50 m |
| Outdoor models | | | | | | | | | |
| D-LINE80-O-6-E0 | 6 | 80 mm | 150 mm | 600 mm | 60 mm | 300 mm | 3 kg | 13 W | 40 m |
| D-LINE150-O-6-E0 | 6 | 150 mm | 250 mm | 956 mm | 60 mm | 556 mm | 6 kg | 14 W | 75 m |
| D-LINE250-O-6-E0 | 6 | 250 mm | 350 mm | 1,493 mm | 60 mm | 1,093 mm | 11 kg | 34 W | 125 m |
| D-LINE450-O-6-E0 | 6 | 450 mm | 600 mm | 2,490 mm | 80 mm | 2,090 mm | 28 kg | 88 W | 225 m |
| D-LINE600-O-6-E0 | 6 | 600 mm | 800 mm | 3,400 mm | 70 mm | 3,000 mm | 44 kg | 133 W | 300 m |
| D-LINE800-O-6-E0 | 6 | 800 mm | 1,000 mm | 4,800 mm | 70 mm | 4,400 mm | 86 kg | 180 W | 400 m |
| D-LINE1000-O-6-E0 | 6 | 1,000 mm | 1,400 mm | 5,700 mm | 70 mm | 5,300 mm | 144 kg | 270 W | 500 m |
| D-LINE1500-O-6-E0 | 6 | 1,500 mm | 2,000 mm | 8,500 mm | 70 mm | 8,100 mm | 290 kg | 510 W | 750 m |

Possible Digit Heights

Indoor:

57 mm
100 mm



digit with 57 mm digit height



digit with 80 mm digit height

Outdoor:

80 mm
150 mm
250 mm
450 mm
600 mm
800 mm
1,000 mm
1,500 mm



digit with 100 mm digit height



digit with 150 mm digit height



digit with 250 mm digit height



digit with 450 mm digit height

Other configurations than indicated above are possible on request.

Example of the order code

D-LINE57-I-6-E0

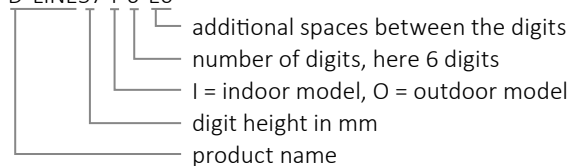



DISPLAY BOARD

LED Matrix D-RTNM

The D-RTNM is an universal, one-color scoreboard that is used to show information or advertising during timing. Even animated movies can be played on the D-RTNM. The display board is controlled online or by retrieving the data previously stored in the internal memory.

The lightweight, rugged aluminum housing allows easy transportation of the scoreboard. The outdoor version is easily read-

able even in direct sunlight. If it is used at night or on rainy days in difficult light conditions, the brightness can be adjusted in 100 levels.

The D-RTNM is controlled non-multiplexed. This increases the life of the LED, increases the brightness, and prevents the display from flickering during TV transmission.



two D-RTNM with small margins

- matrix display board with red LEDs
- models with 1, 3, 4 or 7 LEDs per pixel
- models for outdoor and indoor use
- standard models with a resolution of 16 or 24 pixels in height and 96 or 160 pixels in length
- universal with Ethernet, RS485 and RS232 interface
- internal memory of 4 MB for storing images, logos, animations or participant lists; control from internal memory possible
- possibility to control the display board directly from the terminal of the ALGE-TIMING multisport scoreboard
- possibility to control the bib number, time (also running time) and the rank directly from an ALGE-TIMING timing device; additionally, display of competitor data (e.g. name) from internal memory possible
- adjustment of brightness in 100 steps
- the non-multiplexed control of the LEDs ensures a longer service life and better brightness.
- integrated power supply (100 to 240 VAC)
- sturdy aluminum housing with red plexiglass front



D-RTNM controlled from TdC8001

Options

- customer-specific pixel resolutions
- small marginal widths to assemble several D-RTNMs
- special models with 7 LEDs per pixel
- various LED colors (yellow, green, blue or white)
- connection for temperature sensor
- connection for DCF or GPS synchronization (exact time signal)

Pixel Arrangements

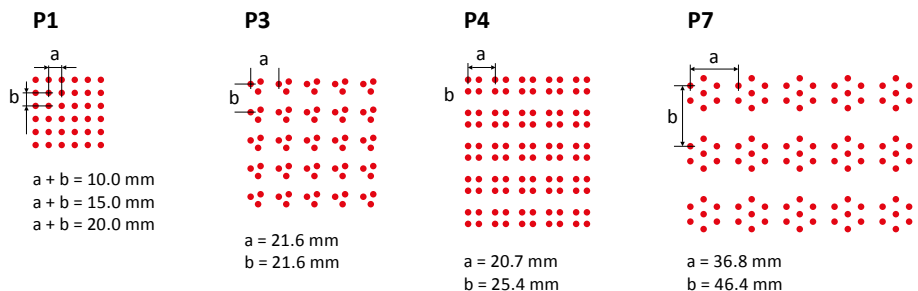

DISPLAY BOARD

LED Matrix D-RTNM

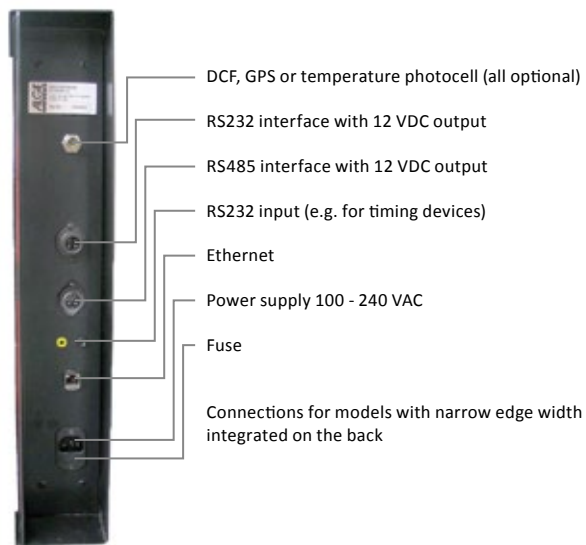

Example of the order code

D-RTNM-P3-16x96-I

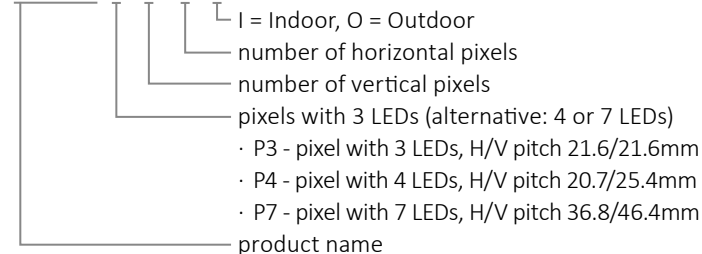

| Model | LEDs per pixel | Vertical pixels | Horizontal pixels | Vertical pixel pitch | Horizontal pixel pitch | Length | Height | Depth | Application |
|--------------------|----------------|-----------------|-------------------|----------------------|------------------------|----------|--------|-------|-------------|
| D-RTNM-P3-16x96-I | 3 | 16 px | 96 px | 21.6 mm | 21.6 mm | 2,300 mm | 400 mm | 97 mm | indoor |
| D-RTNM-P3-16x160-I | 3 | 16 px | 160 px | 21.6 mm | 21.6 mm | 3,700 mm | 400 mm | 97 mm | indoor |
| D-RTNM-P4-16x96-I | 4 | 16 px | 96 px | 20.7 mm | 25.4 mm | 2,200 mm | 500 mm | 97 mm | indoor |
| D-RTNM-P4-16x160-I | 4 | 16 px | 160 px | 20.7 mm | 25.4 mm | 3,500 mm | 500 mm | 97 mm | indoor |
| D-RTNM-P3-16x96-O | 3 | 16 px | 96 px | 21.6 mm | 21.6 mm | 2,300 mm | 400 mm | 97 mm | outdoor |
| D-RTNM-P3-16x160-O | 3 | 16 px | 160 px | 21.6 mm | 21.6 mm | 3,700 mm | 400 mm | 97 mm | outdoor |
| D-RTNM-P4-16x96-O | 4 | 16 px | 96 px | 20.7 mm | 25.4 mm | 2,200 mm | 500 mm | 97 mm | outdoor |
| D-RTNM-P4-16x160-O | 4 | 16 px | 160 px | 20.7 mm | 25.4 mm | 3,500 mm | 500 mm | 97 mm | indoor |

Examples of configurations, changes possible upon request.



Example of a D-RTNM-P3-24x96-O



DISPLAY BOARD

Video Wall

Video walls are used for sports events in stadiums, as stage displays at music events, trade fairs, fashion shows or for advertising. The size of video walls varies from one pixel pitch from 1.42 mm to 26.7 mm, and each version can be delivered

individually with video curtains or LED curtains or curved video walls for building facades. Video walls are available as perimeter display with soft top cushion and foot stand.

A video wall consists of individual modules that are assembled in any order. Depending on the model, maintenance is performed on the front or rear.

Due to the quick-release fasteners it is possible to build up the entire video wall in a few minutes.



Model CH-LITE II (Indoor Display Board)

Modular design with SMD LEDs (3 in 1 SMD LEDs) and very light modules (approx. 18 kg). The modules have the dimensions of 768 mm x 768 mm or 576 mm x 384 mm and are very slim with 92 mm. There are models that allow maintenance from the front rear. A quick-release system allows al quick setup. The power consumption is low. For the small modules, it can be up to 150 W; and for the large ones, up to 300 W. This makes it ideal for mobile use (e.g. for renting it out).

| Model | CH-L-1,4 | CH-L-3 | CH-L-6 | CH-L-8 | CH-L-10,6 | CH-L-12 |
|-------------|----------|--------|--------|--------|-----------|---------|
| Pixel pitch | 1.42 mm | 3 mm | 6 mm | 8 mm | 10.6 mm | 12 mm |



housing: 768 x 768 mm



housing: 576 x 384 mm

Model CH-EIII (Outdoor Display Board)

Modular design with SMD LEDs (3 in 1 SMD LEDs) and very light modules (approx. 20 kg).The module dimensions are 768 mm x 768 mm. The modules have a depth of 120 mm. Maintenance is carried out from the front. A quick-release system allows for rapid assembly. This makes it ideal for mobile use (e.g. for renting it out).

The combination of a specially developed mask and a lens plate with ball lens on the top of each pixel greatly reduces the reflection of sunlight and ensures the best contrast ratio. In addition, the lenses protect against being hit, for example, by balls.

The model with 72 x 72 pixels and a pixel pitch of 10.3 mm is suitable for 3 modules as a flexible display board, in combination with a timing device. We optionally offer a flight case for safe transport as well as stand and rubber protection for LED advertising boards.

| Model | CH-EIII-6.4 | CH-EIII-8 | CH-EIII-8.75 | CH-EIII-10.65 | CH-EIII-12S | CH-EIII-16S |
|-------------|-------------|-----------|--------------|---------------|-------------|-------------|
| Pixel pitch | 6.4 mm | 8 mm | 8.7 mm | 10.6 mm | 12 mm | 16 mm |



Model CH-EII (Outdoor Display Board)

Modular design with separate LEDs for each color of a pixel (red, green, blue). A standard module has the dimensions of 1,280 mm (H) x 640 mm (L) x 122 mm (T). There are models for which maintenance is possible on the front or rear. A quick-lock system ensures a quick setup. Larger blocks can also be supplied for fixed installations.

| Model | CH-EII-10 | CH-EII-13.3 | CH-EII-16 | CH-EII-20 | CH-EII-26.7 |
|-------------|-----------|-------------|-----------|-----------|-------------|
| Pixel pitch | 6.4 mm | 8 mm | 8.7 mm | 10.6 mm | 12 mm |
| Virtual | 5 mm | 6.7 mm | 8 mm | 10 mm | 13.35 mm |

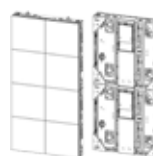

fixed installation 1,280 x 640 mm Installation from the front



fixed installation 1,280 x 640 mm Mounting from behind

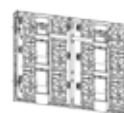

mobile use



E2L Series 960 x 1,536 mm

These modules can be used for fixed installation, rental systems, but also for gantry advertising. Modules are available for front or rear service.

DISPLAY BOARD

Video Wall

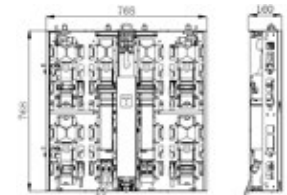
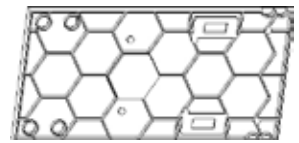

Honeycomb Structure Module

The module is a new type of composite back shell with excellent features, such as high intensity, low cost and outstanding heat dissipation. The module structure is simple and three-dimensional, and both sides of the bottom shell have reinforcing ribs.

Modules

Slim and compact modules for permanent installations and rental systems are offered. Both have the same measurements.

Setup

The modules are then locked with toggle clamps for quick assembly without tools.

Hanging Model

Optionally, there are special hanging beams for the modules with which you can hang up to 20 modules.

Flight Cases

Specially developed flight cases (optional) guarantee safe transport and protected storage of the modules.

Wiring of the Mobile Modules

A simple wiring between the modules with high-quality connectors ensures maximum reliability. Only two cables for the power supply and signal line must be connected from module to module.

Power Supply Hot Backup

The power supply is an essential component of a video wall and has direct influence on visibility. ALGE-TIMING uses a backup function for the power supply to avoid breakdowns of parts of the video signal due to defective power supply units. The modules are equipped with two power supplies. If one of them fails, the second power supply takes over and powers the module. A fault indication with LEDs indicates a defective power supply to the user. If the dynamic load is less than half the total power consumption of the module, the images will usually be displayed on the video wall. Otherwise, the brightness of the screen is automatically reduced by half.

Signal Hot Backup System

The signal hot backup system improves the reliability of a video signal. If automatic error detection is activated, data can be fed in from two sides. If a line fails, the other line takes over within milliseconds.

Maintenance

The modules are modular and maintenance is easy to carry out.





DISPLAY BOARD

Video Wall

The specifications for LED video walls vary widely, depending on the application. Here is an overview of the most important data:

Pixels

A pixel is the smallest unit on a video wall and consists of one or more LED.

Pixel Pitch

The pixel pitch is measured from the center of each pixel to the center of the next pixel. Attention: There is a physical pixel pitch and a pixel spacing that can be achieved by pixel sharing. It is always important to compare the physical pixel spacing, since the image quality is practically determined only by that.

Pixel Size

The filling level is responsible for the fact that the image does not lose sharpness at longer distances. The larger the single pixel compared to the pixel pitch, the better the fill level of the display board.

LED / Pixel

Depending on the design, one pixel consists of one or more LEDs. Especially for video ads, it is important to find the right balance of the colors. For this reason, four red, two green and two blue LEDs are used, for example, at a pixel spacing of 28 mm.

Resolution

The resolution is the sum of the physical pixels on the display board. The higher the resolution, the better the image quality.

Pixel Sharing or Virtual Resolution

In pixel sharing, individual LEDs are used by adjacent pixels to form virtual pixels. If a display board supports pixel sharing, its virtual resolution is four times as high as the physical. However, the image quality at the same physical resolution is much better.

Luminosity

The luminosity is expressed in cd/m^2 or in Nit. Especially for full-color systems, there are different ways to specify the brightness. If all three basic colors with the highest intensity, for example, reach a luminosity of $7,000 cd/m^2$, the same

brightness is present, but after white balance, is then indicated as $5,000 cd/m^2$. Accordingly, these two data are technically similar but misleading for the customer. For different display boards, a different brightness is required for outdoor applications.

Single color $3.000 cd/m^2$
Full color $5,000 cd/m^2$, white balance

Viewing Angle

This information is specified differently. Both the maximum viewing angle at which the display board darkens, as well as the angle at which the scoreboard still has 50 % of the nominal brightness (Half Center Brightness), are indicated. It is important to ensure that the viewing angle for the comparison of different video walls is also taken into account with the same specifications.

Refresh Rate

The higher the refresh rate, the better the quality of the display board.

Static or Multiplexing Driving

The control of a video wall should be done statically. This can be checked with any digital camera. If the picture flickers in the viewfinder, the control is multiplexed. If a TV camera is now shooting the display, the picture also flickers in the TV. Static control is technically much more complex and expensive, but also increases the life of the LEDs enormously.

Outdoor

The LEDs are cast with a special potting compound with a disc. High quality products are only shed, as each disc reflects.

Single Color

The display can only show one color. There are, however, still very big differ-



ences between the different video walls. In our systems, a color can also be divided into 256 or 4.096 brightness levels. Such a system can be used to display pictures or movies as on a black-and-white TV.

Video Display

One pixel consists of three different colored LEDs, red, green and blue. If these three colors are mixed, depending on the system, up to 10.73 trillion colors are obtained, the standard is 16.7 million, with ALGE-TIMING products with 68.719 million colors.

DISPLAY BOARD

Video Wall





DISPLAY BOARD

Lap Counter D-LC

The lap counter D-LC is available in different versions with two or three digits, which are 150 or 250 mm high. One has a choice of models with one, two or three sides. The lap counter is equipped with an integrated power-pack consisting of battery and charger, tripod, external push button and, if desired, a bell.

For outdoor use, a robust aluminum housing was been developed for the lap counters, in which the extra bright, red LEDs are easily readable, even in direct sunlight.

Operating Modes of the Lap Counter

Countdown Laps

The lap counter starts counting from a preset number of rounds towards zero, and then returns to the preset value.

Count up Laps

The number is counted up with each round being added to the number.



| Model | Digit height | Maximum reading distance | Number of digits | Number of pages | Bell |
|-------------|--------------|--------------------------|------------------|-----------------|------|
| D-LC2-15-1 | 150 mm | 70 m | 2 | 1 | no |
| D-LC2-15-2 | 150 mm | 70 m | 2 | 2 | no |
| D-LC2-15-3 | 150 mm | 70 m | 2 | 3 | no |
| D-LC2-25-1 | 250 mm | 120 m | 2 | 1 | no |
| D-LC2-25-2 | 250 mm | 120 m | 2 | 2 | no |
| D-LC2-25-3 | 250 mm | 120 m | 2 | 3 | no |
| D-LC3-15-1 | 150 mm | 70 m | 3 | 1 | no |
| D-LC3-15-2 | 150 mm | 70 m | 3 | 2 | no |
| D-LC3-15-3 | 150 mm | 70 m | 3 | 3 | no |
| D-LC3-25-1 | 250 mm | 120 m | 3 | 1 | no |
| D-LC3-25-2 | 250 mm | 120 m | 3 | 2 | no |
| D-LC3-25-3 | 250 mm | 120 m | 3 | 3 | no |
| D-LCB2-15-1 | 150 mm | 70 m | 2 | 1 | yes |
| D-LCB2-15-2 | 150 mm | 70 m | 2 | 2 | yes |
| D-LCB2-15-3 | 150 mm | 70 m | 2 | 3 | yes |
| D-LCB2-25-1 | 250 mm | 120 m | 2 | 1 | yes |
| D-LCB2-25-2 | 250 mm | 120 m | 2 | 2 | yes |
| D-LCB2-25-3 | 250 mm | 120 m | 2 | 3 | yes |
| D-LCB3-15-1 | 150 mm | 70 m | 3 | 1 | yes |
| D-LCB3-15-2 | 150 mm | 70 m | 3 | 2 | yes |
| D-LCB3-15-3 | 150 mm | 70 m | 3 | 3 | yes |
| D-LCB3-25-1 | 250 mm | 120 m | 3 | 1 | yes |
| D-LCB3-25-2 | 250 mm | 120 m | 3 | 2 | yes |
| D-LCB3-25-3 | 250 mm | 120 m | 3 | 3 | yes |

Other configurations are available on request.

Technical Data

- one-, two- or three-sided models available
- two or three digits
- red numeric seven-digit numbers
- connections:
 - banana socket for external buttons
 - power supply: internal battery or network mains (100 - 240 VAC)
- integrated power-pack (battery and charger)
- automatic power saving mode
- fastening: 3/8 inch thread for tripod
- black aluminum case with red plexiglass front
- tripod for the lap counter
- operating temperature: -20 °C to +60 °C
- external button with 10 m cable

Example of the Article Code

D-LCB2-25-2

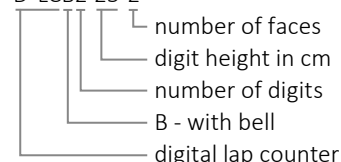

digit with 150 mm digit height



digit with 250 mm digit height

DISPLAY BOARD

Time Temperature Display Board D-SAT

0:00:00

The D-SAT series of the multi-functional display board is equipped with a precise and elegant time display and can be used very flexibly, thanks to extra bright LED digits.

- models with 57 and 100 mm digit height for indoor applications
- models with 80, 150, 250, 300, 450, 600, 800, 1,000 or 1,500 mm digits can also be used for outdoor applications.
- 4 or 6 digits (alternatively other configurations e.g. with extra temperature field)
- standard color for the digits: red (options: yellow, green, blue or white)
- in- or outdoor models (readable in direct sunlight)
- display of time, date and optional temperature or relative humidity
- 12 or 24 hour display format
- up to 64 alarm times (optional), relay contact 1A
- time setting with a key attached to the housing or via external synchronization with DCF, GPS, Ethernet
- precise time due to internal real-time clock, after power outages or network interruptions no time settings necessary; accuracy of ± 4 minutes per year at 25 °C
- automatic brightness control for outdoor use (option)
- automatic time changeover (summer time - winter time)
- network of several clocks with a master clock and auxiliary clocks
- with an average life of 100,000 hours, LED displays are durable and reliable.
- robust, black-coated aluminum housing for wall mounting with one-sided models, and ceiling mounting with double-sided models; optionally, also available with different color or other attachment
- 100 to 240 VAC 50/60 Hz



The clocks can communicate via RS485 or Ethernet. A digital clock is the master clock and controls all the auxiliary clocks. The master clock is synchronized via GPS, DCF, Internet or a PC.

The main clock can use one of the display boards of the system, or a control box, or a rack control box.

You can combine display boards for indoor and outdoor use.

| Model | Digit height | Readability | Outside dimensions with 4 digits | Outside dimensions with 6 digits | Depth SS/DS |
|-----------|--------------|-------------|----------------------------------|----------------------------------|-------------|
| D-SAT57 | 57 mm | 28 m | 400 x 130 mm | 500 x 130 mm | 60 / 110 |
| D-SAT80 | 80 mm | 40 m | 450 x 150 mm | 600 x 150 mm | 60 / 110 |
| D-SAT100 | 100 mm | 50 m | 650 x 180 mm | 750 x 180 mm | 60 / 110 |
| D-SAT150 | 150 mm | 75 m | 730 x 250 mm | 960 x 250 mm | 60 / 110 |
| D-SAT250 | 250 mm | 125 m | 1,100 x 350 mm | 1,500 x 350 mm | 60 / 110 |
| D-SAT300 | 300 mm | 150 m | 1,300 x 400 mm | 1,850 x 400 mm | 60 / 110 |
| D-SAT450 | 450 mm | 225 m | 1,900 x 600 mm | 2,490 x 600 mm | 80 / 110 |
| D-SAT600 | 600 mm | 300 m | 2,490 x 800 mm | 3,400 x 800 mm | 70 / 110 |
| D-SAT800 | 800 mm | 400 m | 3,300 x 1,000 mm | 4,800 x 1,000 mm | 70 / 110 |
| D-SAT1000 | 1,000 mm | 500 m | 3,900 x 1,400 mm | 5,700 x 1,400 mm | 70 / 110 |
| D-SAT1500 | 1,500 mm | 750 m | 5,800 x 2,000 mm | 8,500 x 2,000 mm | 70 / 110 |

SS - single-sided display board, DS - double-sided display board

Options

- GPS - GPS time synchronization
- ETH - Ethernet-LAN-time synchronization
- DCF - radio-time synchronization
- A - alarm output (up to 64 alarm times)
- T - temperature sensor
- RH - relative humidity sensor
- LS - light sensor for brightness control



Example of the Order Code

D-SAT250-6-SS-I-M-T-GPS-A

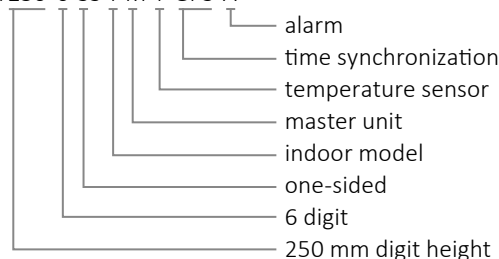



ATHLETICS



START



The various equipment required in athletics begins with simple training systems for the timing with photocells and goes up to the photo finish system, which is used in bigger events. For this purpose, there are all kinds of accessories, such as wind-gauges and lap counters, concentration clocks, distance meas-

uring devices (theodolites) and various display systems from ALGE-TIMING.

A complete athletic track with a corresponding timing system can be seen in the figure.

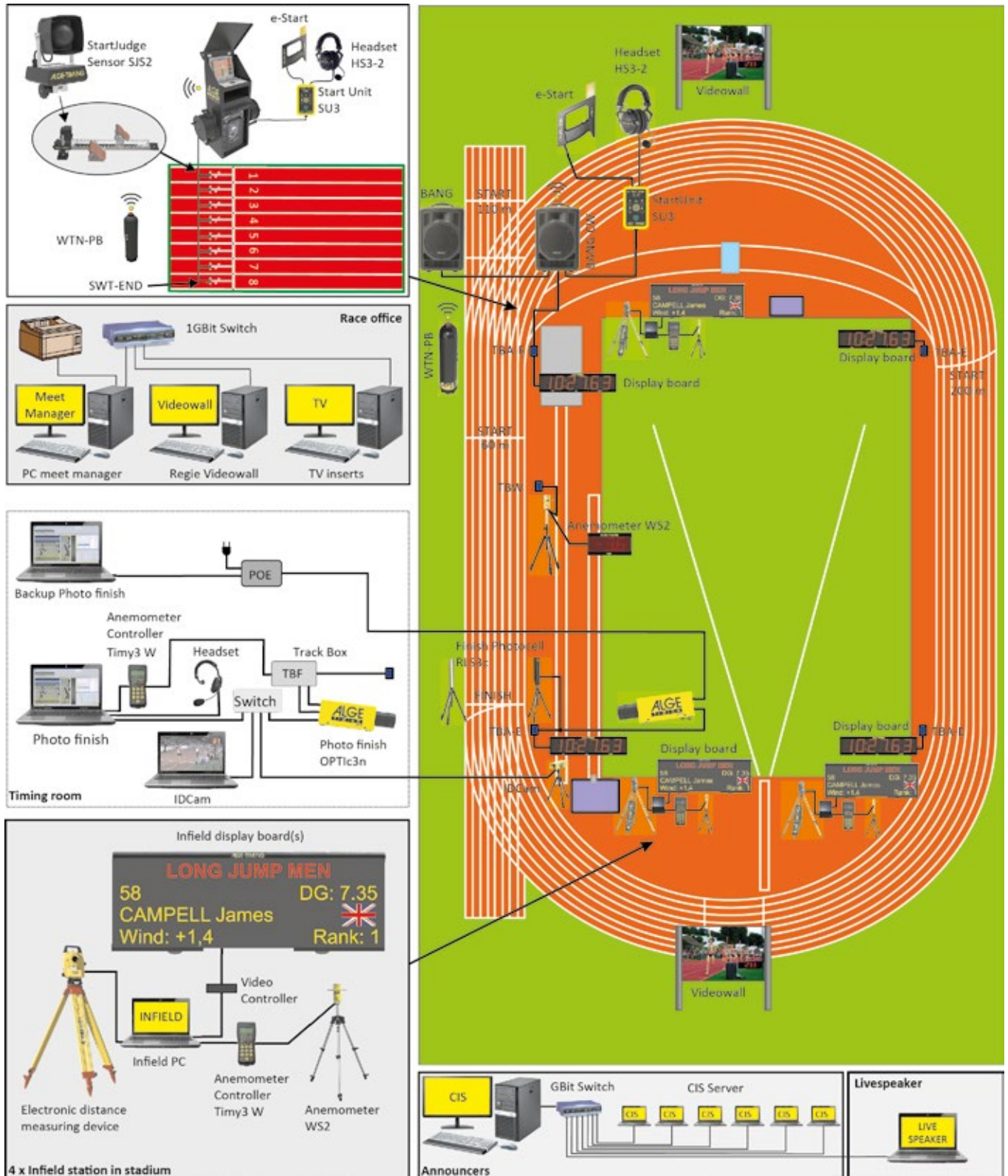

All computers in the illustrated system are connected in a network.



The ALGE-TIMING Windspeed WS2 works with a calorimetric mass flow sensor, which allows fast and accurate wind measurement.

The “miniaturized calorimetric mass flow sensor” has excellent dynamics. Based on the small involved masses of the sensors and the environment thermally influenced for the measurement, time constants in the range below 1 ms can be achieved without difficulty, depending on the type of media used.

The optimal design of the wind sensors and the fast response time for a measurement ensure that no wind changes can occur between the measurements and that measurements below 1 m/s are possible. For a measurement in track and field, up to 13 seconds are measured. The more measurements are made during this time, the more accurate the average value over this period will be.

The WS2 does not need any re-calibration since no mechanical parts are used. The components retain their characteristics over the entire service life, and there are no disturbances caused by humidity or temperature fluctuations.

The WS2 can be connected to the Timy3 W terminal via cable or radio. In the radio solution, the Timy3 W has a built-in radio and the Wireless Timing Network WTN-WS is required on the anemometer side. The WS2, as well as the scoreboard, can be connected here.



Anemometer WS2

for measuring the wind speed during running races and long jump



Wireless Network WTN-WS

With the WTN-WS, the anemometer and the wind display board can be operated via radio connection.



Cable Reel KT245Z10

100 m cable for connecting the anemometer WS2 with the Timy3 W terminal



Timy3 W Terminal

The Timy3 W can be used to operate the anemometer and to display the wind speed. It also allows one to connect the ALGE-TIMING photo finish OPTIc3 and operate the anemometer remotely. With the WTN-WS, the system can also be operated without cables.

In addition, the Timy3 W can also be used as a timing device for training purposes, or as a concentration clock.



Tripod TRI128

The anemometer is placed on the tripod and an intermediate adapter in order to reach the prescribed measuring height of 1.22 m.

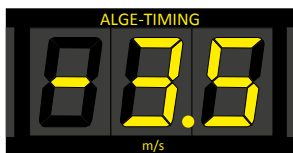
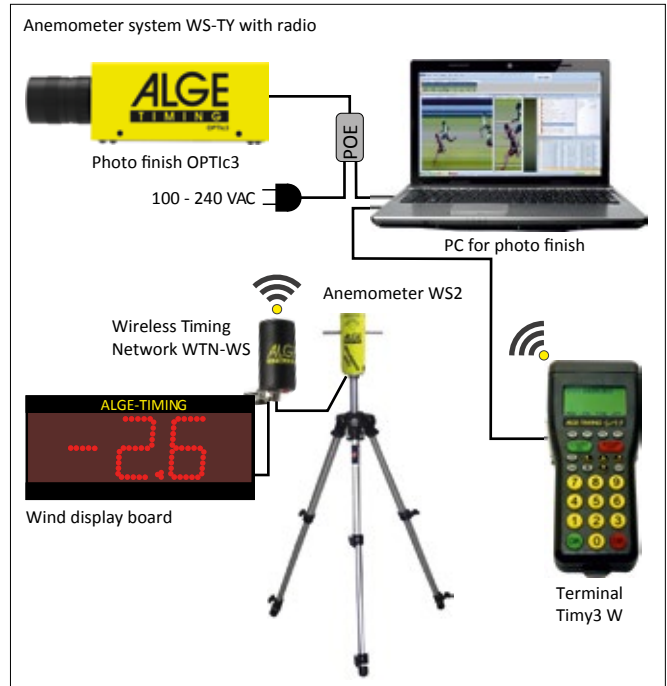
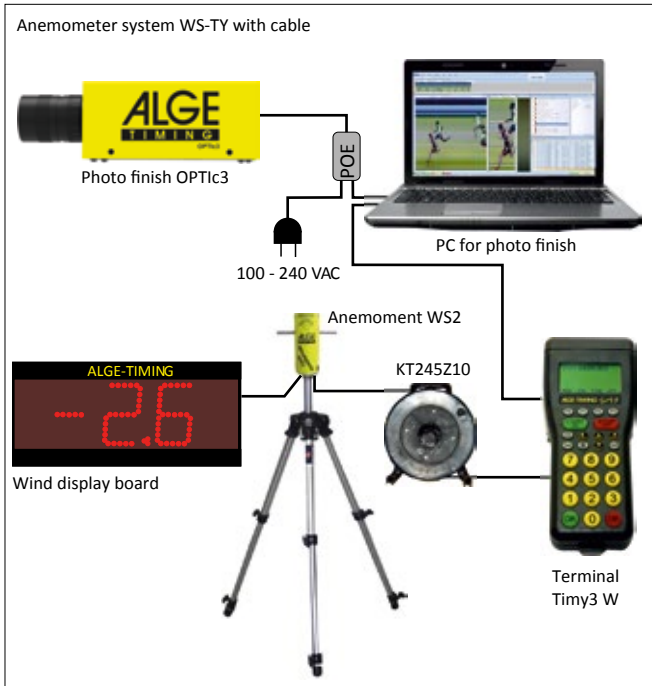

The display board makes the wind speed visible to the athletes and the audience. There are display boards with different technologies and digit heights.

Sets for the Anemometer

Anemometer WS2-TY

- anemometer WS2
- Timy3 W terminal
- tripod TRI128
- tripod adapter
- cable reel KT245Z10 (100 m cable)

Anemometer WS2-W

- anemometer WS2
- Timy3 W Terminal
- wireless Timing Network WTN-WS
- tripod TRI128
- tripod adapter

Optional accessories

- case with foam insert
- display board
- terminal Timy3 WP with printer



ATHLETICS

False Start System Start Judge SJ2

The Start Judge SJ2 is a false start system for track and field at sprint races (up to 400 m). The system consists of a Start Judge transport cart in which the controller and BANG are accommodated. The sensors SJS2 are mounted on each starting block. Integrated into the Start Judge is also a loudspeaker sys-

tem, which enables the starter to give oral start commands to the athletes. The start sound (simulated start shot) is emitted via the loudspeaker installed in the start sensor, and the BANG. This allows a fair start, due to all competitors hearing the start sound at the same time.



Start Judge sensor SJS



Start Judge sensor SJS2 attached to the start block STAMA



Start Judge cart with built-in controller, speaker, and battery



A Start Judge sensor is connected to each starting block. The sensor is triggered by movement. The system checks the start signal with each sensor impulse. If a sensor impulse occurs before or within 1/10 of a second after the start signal, a false start is triggered.

There are two ways to display a false start:

- automatic Start Judge SJ2 start sound that recalls the competitors (default setting)
- The false start tone is only heard in the headset of the starter and the false starter.

The force profile of each starter is recorded as a curve, which is then displayed on the connected PC or tablet. This allows the start judge to check every start at a later stage.

The Start Judge SJ2 works with cable or radio connection (proven ALGE-TIMING WTN system).

ATHLETICS

False Start System Start Judge SJ2

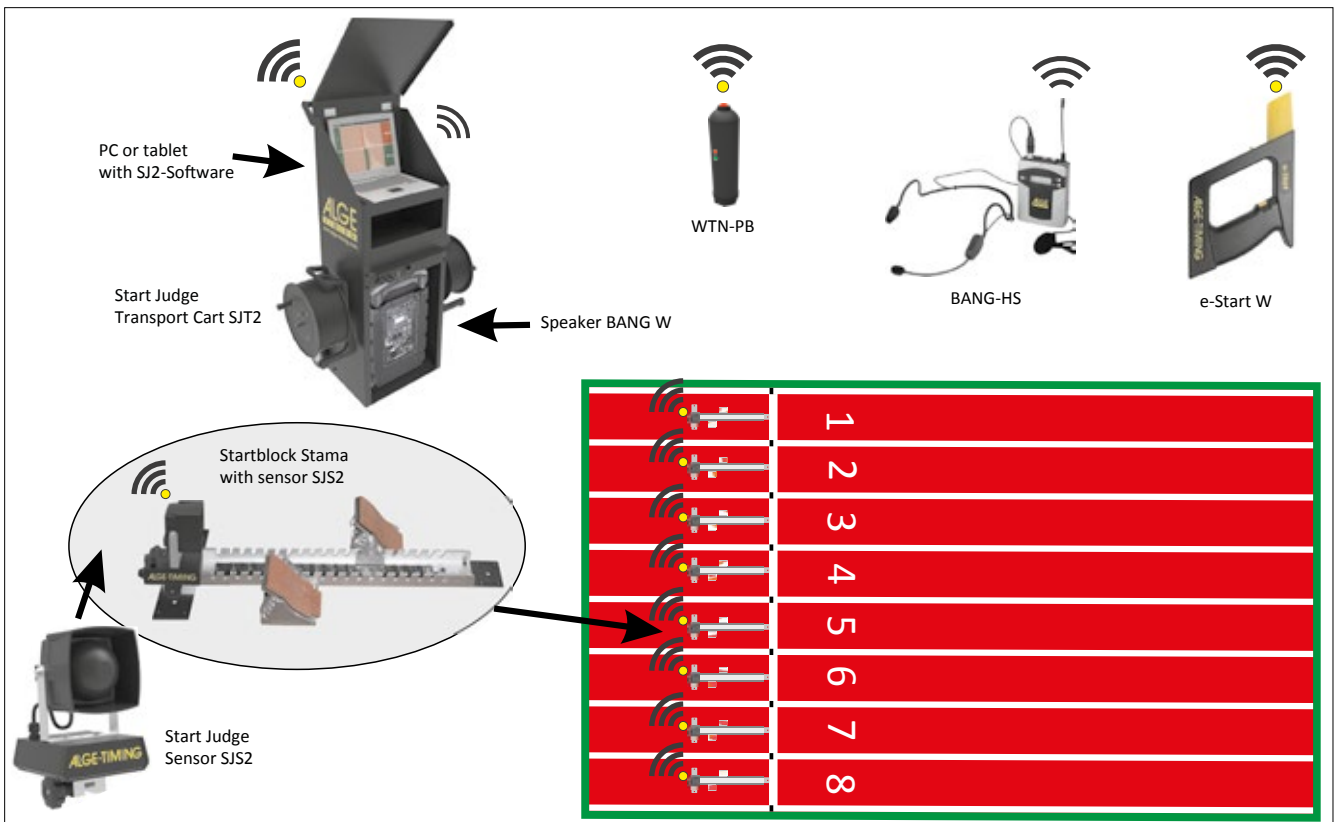
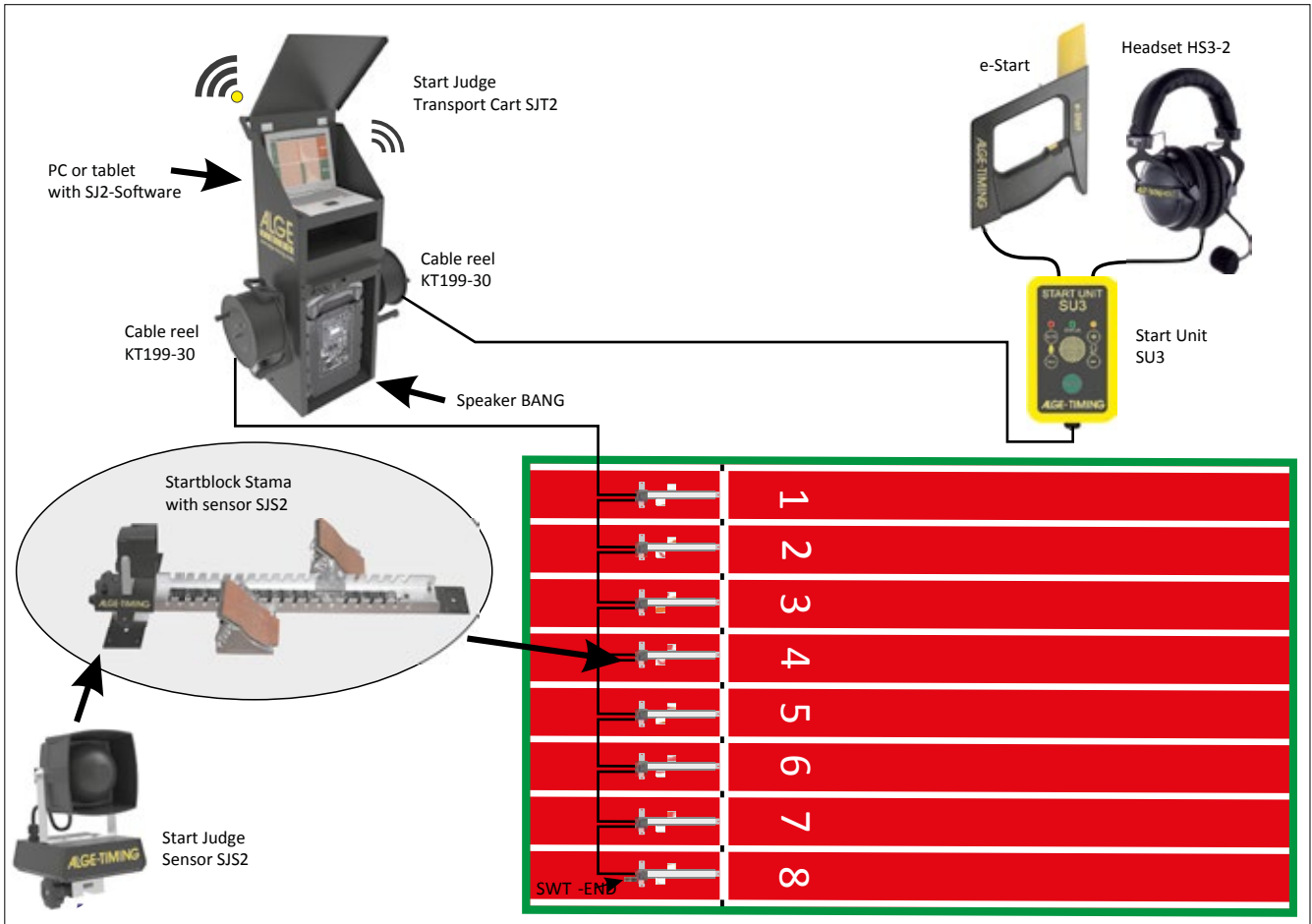



ATHLETICS

Infield Display Boards

The selection of a suitable infield display board plays an important role in the spectators' field of view. The display board should not obstruct the view and obscure television trans-

missions. ALGE-TIMING therefore has a wide selection of different infield display variations and custom designs with other pixel pitches or double-sided displays.

General Information

The greatest flexibility is achieved with individual display boards, which are built double- or triple-sided. In this case, the display board can also be used, for example, for advertising purposes with graphics and animations.

Optionally, the infield scoreboard has a rotary system for single or double-sided display boards.

To control the infield scoreboard, a PC with the Meet Manager software, is connected to the network. The software can also transfer data from other devices, e.g. distance measuring device or wind measuring device.



Red Matrix LED Infield Display Boards

D-RTNM-P1V4-24x96-O

- single-sided matrix display board
- suitable for outdoor use
- LED matrix area with 24 x 96 pixels
- 1 red LED per pixel, 20 mm pixel spacing
- active display area: 1,920 x 480 mm
- display board dimensions: 1,960 x 520 x 100 mm (L x H x D)

D-RTNM-P3-24x96-O

- single-sided matrix display board
- suitable for outdoor use
- LED matrix area with 24 x 96 pixels
- 3 red LEDs per pixel, 21.6 mm pixel spacing
- active display area: 2,073.6 x 523.2 mm
- display board dimensions: 2,115 x 565 x 100 mm (L x H x D)

Specifications (for all models D-RTNM)

interface: RS 232 or Ethernet

power supply: 100 to 240 VAC 50/60 Hz



ATHLETICS

Infield Display Boards



Example of a Video Wall Infield Display Board CH-EIII-10.6 - 72 x 216 Pixels

- 3 modules, pixel pitch = 10.6 mm, 72 x 72 pixels
- resolution of the entire display board: 216 x 72 pixels (L x W)
- active surface: 2,304 x 768 mm (L x W)
- On the floor, one stand can be installed per module (optional).
- A soft rubber protector can be mounted (optional).
- suitable for outdoor use

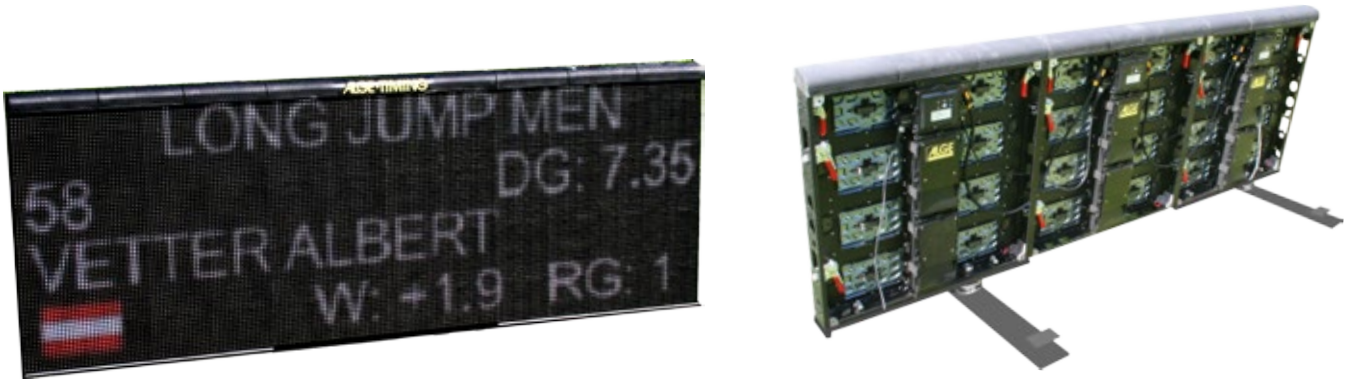

OUTDOOR SYSTEMS SMD

| Model | CH-EIII-6.4 | CH-EIII-8 | CH-EIII-8.7S | CH-EIII-10.6S | CH-EIII-12S | CH-EIII-16S |
|-------------|-------------|-----------|--------------|---------------|-------------|-------------|
| Pixel pitch | 6.4 mm | 8 mm | 8.7 mm | 10.6 mm | 12 mm | 16 mm |

OUTDOOR SYSTEMS DIP

| Model | CH-EII-10 | CH-EII-13.3 | CH-EII-16 | CH-EII-20 | CH-EII-26.7 |
|-------------|-----------|-------------|-----------|-----------|-------------|
| Pixel pitch | 10 mm | 13.3 mm | 16 mm | 20 mm | 26.7 mm |
| Virtual | 5 mm | 6.7 mm | 8 mm | 10 mm | 13.35 mm |





ATHLETICS

Concentration Clock CC

The concentration clock shows the countdown time which remains for an attempt of an athlete at infield disciplines. The countdown can be set quickly and easily at any competition.

The display board is offered with LED technology or with bistable electromagnetic elements, and is available with 15 or 25 cm digit height and three digits for displaying the minutes and seconds.

The concentration clock is controlled by the user-friendly terminal Timy3, which is connected via a 10 m long cable and operated from the judge's table.



Timy3 W

Components of the System

Timy3 W

The Timy3 W is the operator terminal for the display board, which sets the countdown time and restarts for each attempt.

Option 1: Display Board D-LINE150-O-3-E0

- 3 red LEDs
- digit height 15 cm (visibility up to approx. 70 m)
- time display until 9:99 (minutes and seconds)
- power supply via mains supply 100 - 240 VAC

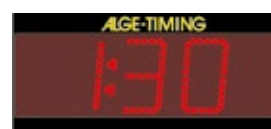

D-LINE150-O-3-E0

Option 2: Display Board D-LINE250-O-3-E0

- 3 red LEDs
- digit height 25 cm (visibility up to approx. 120 m)
- time display until 9:99 (minutes and seconds)
- power supply via mains supply 100 - 240 VAC

Option 3: Display Board GAZ5 315 PP5

- 3 yellow electromagnetic digits
- digit height 15 cm (visibility up to approx. 70 m)
- time display until 9:99 (minutes and seconds)
- power supply internal rechargeable battery or network mains supply 230 VAC



GAZ5 315 PP5

Option 4: Display Board GAZ5 325 PP5

- 3 yellow electromagnetic digits
- digit height 25 cm (visibility up to approx. 120 m)
- three digits for time display up to 9:99 (minutes and seconds)
- power supply internal rechargeable battery or network mains supply 230 VAC

ATHLETICS

Distance Measuring Devices (Theodolites)



The various models of the distance measuring devices (theodolites) differ primarily in the prism search, which is manually adjusted for simple theodolites, in order to subsequently calculate the width in the computer-assisted Infield Client.

More comfortable theodolite models search for the prism at the

push of a button independently and display the width on the display of the device.

All theodolites offered by ALGE-TIMING have an RS232 interface to transfer the measured distance to the PC with the Infield Client program.



How do theodolites with automatic prism search operate?

For devices with automatic search mode, the view finder rotates around the stationary axis and sends a vertical scanning laser beam. If the prism is found, the rotary search movement stops, and the prism is automatically scanned.

The theodolite is pivoted in the direction of the prism, and upon pressing on the push button, the distance or height is automatically displayed after a short time.

Software is available for the following disciplines

Throwing

- discus
- shot put
- hammer throw
- javelin

Jumping

- long jump
- triple jump
- high jump
- pole vault





CYCLING





With timing at cycling events, ALGE-TIMING has a long tradition and is very much appreciated by customers, from simple club to professional events. ALGE-TIMING timing devices are used worldwide for countless events in road racing, track racing or mountain biking.

The photo finish OPTic3 is the ideal device for determining the winner in almost every cycling event. For track events, devices specially developed for this purpose are available, for example,

the CycleStart or the start machine ST-BSM1. ALGE-TIMING has a wide range of timing devices and accessories for mountain biking which makes it much easier to pull off an event.





CYCLING - ROAD

Road Race

At a road or stage race, for example, the start is triggered with the electronic start gun and a lap counter determines the number of laps at the finish line. The display board D-LINE or GAZ5 is mounted at the roof of the support vehicle in order to make the results visible for viewers and participants. Two display boards, which can be seen from the front and from the rear, are even more effective.

At the finish line, a photocell stops the time and controls the recording of the photo finish and the IDCam. A display board with the run time and one with the time difference can be attached to the finish traverse.

If the start is only a few hundred meters from the finish, one can set up a voice connection between start and finish. In the case of stage races where the finish is separated by many kilometers from the start, the photo finish system can be synchronized separately via a timing device, such as the Timy3.



CYCLING - ROAD

Time Trail



The Startclock ASC3 belongs to the accessories in timed races as it helps to regulate the start sequence: The time is effectively started by a tape switch at the start, measured by the timing device TdC8001 and stopped in the finish by a photocell. When the start is near the finish, starter and timing operator can

communicate with a headset. A finish arrival announcer can tell the bib number of the arriving cyclists to the timing operator.

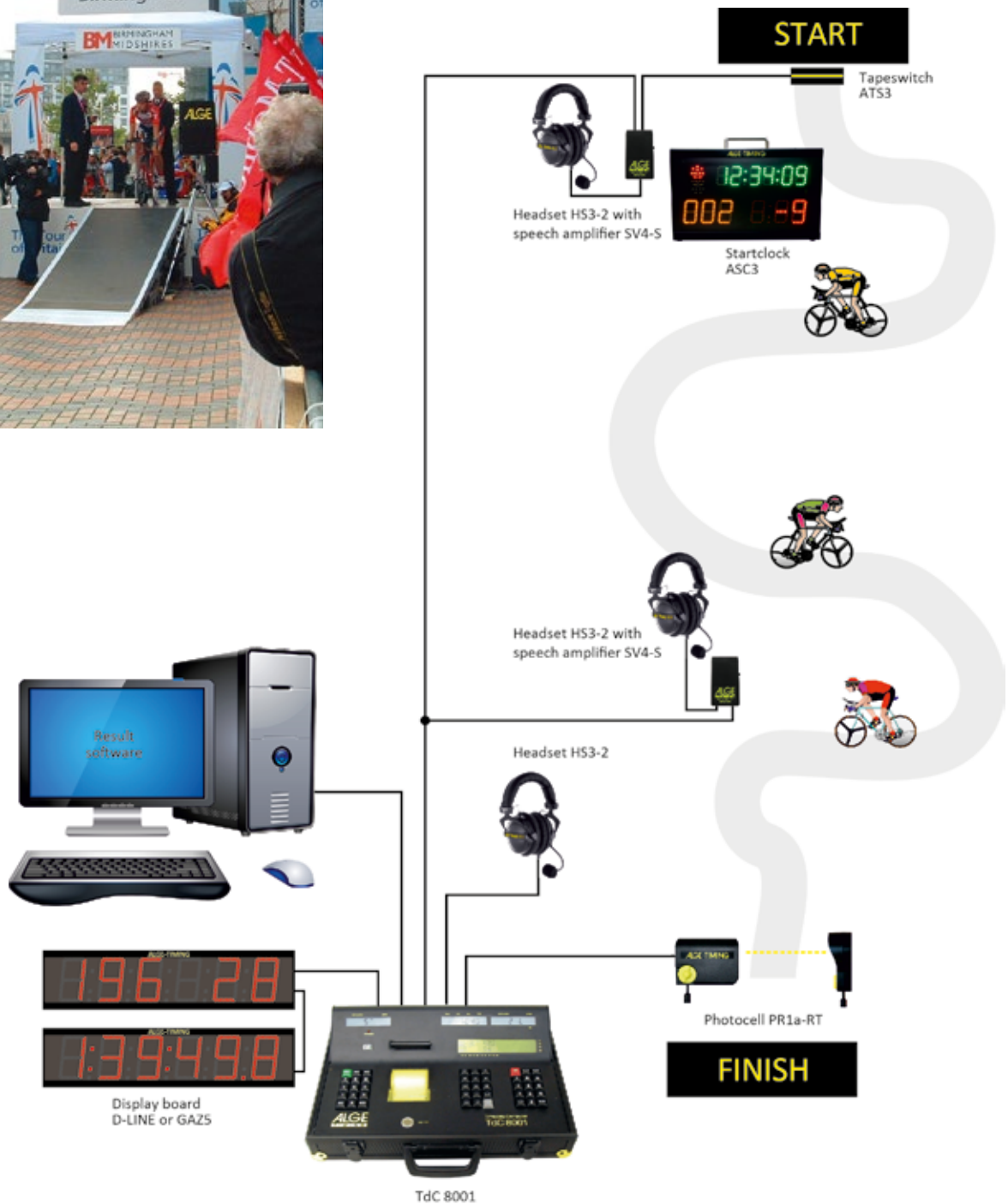

All computers in the illustrated system are connected in a network.



CYCLING - TRACK CYCLING

Timing System

ALGE-TIMING can offer the complete technical equipment for carrying out track cycling events may they be large or small. This ranges from simple training systems to complete systems for major events.

All accessories are also available e.g. starting machines, starting display boards with countdown and cabling solutions.



CYCLING - TRACK CYCLING

Timing System



The timing system of a complete track cycling system as shown below, can also be adapted to smaller tracks.

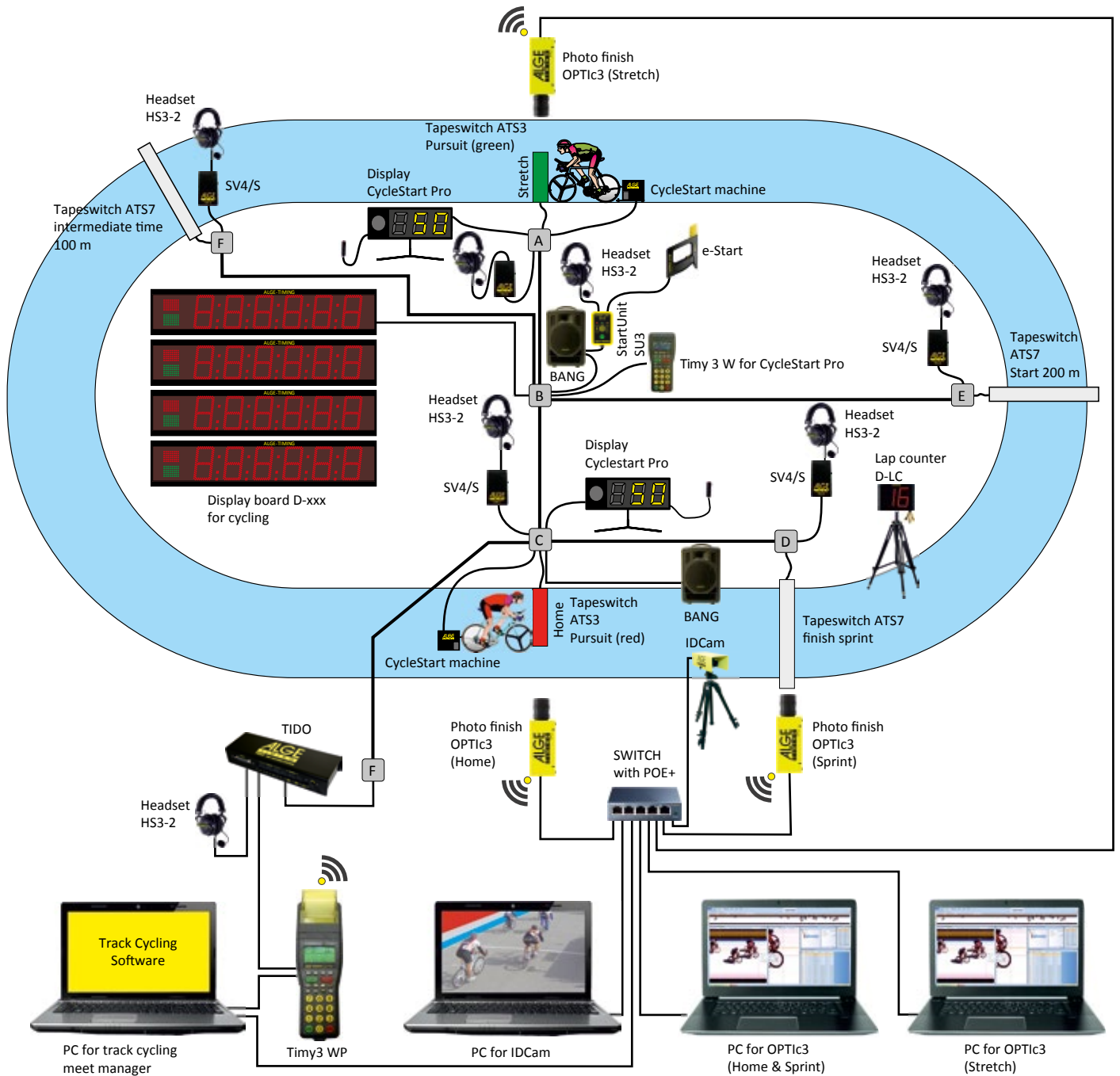

All computers in the illustrated system are connected in a network.



CYCLING - TRACK CYCLING

CycleStart

The CycleStart is a multi-purpose system specially developed for track cycling, which can be used at the start of all competitions with electronic countdown (e.g. pursuit). The loudspeaker integrated in the display board emits the interval- and start sound.

It includes all adapters for the cabling of the system. ALGE-TIMING offers fix or flexible cabling options that can be ordered as needed.

The CycleStart is used after the start as a lap counter and manual timing system.

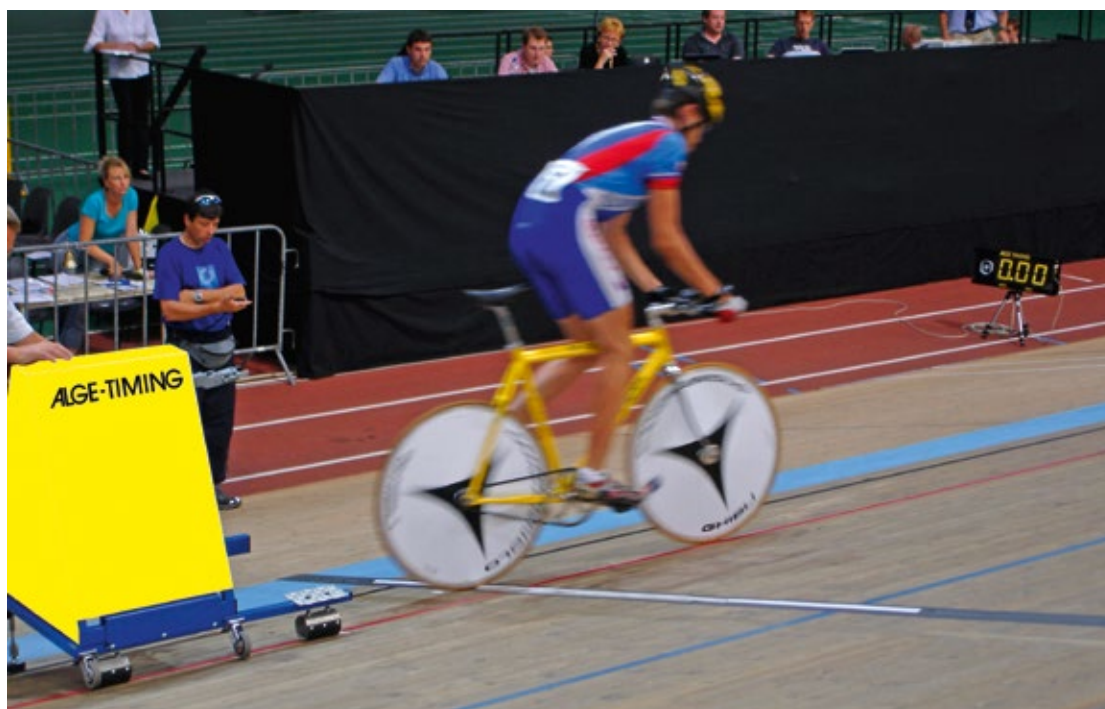

Mobile System - CycleStart M100

- 2 x CycleStart display board CS-DB
- 2 x tripod TRI128
- control unit Timy3 W
- power supply PS12A
- 2 x manual push button 023-02 for the lap counter
- distributor central VELO-MB
- distributor red VELO-MA
- distributor green VELO-MC
- distributor sprint VELO-MD
- distributor start 200 m VELO-ME
- distributor timing VELO-M-F
- distributor split time 100 m VELO-MG

Permanent System - CycleStart P100

- 2 x CycleStart display board CS-DB
- 2 x tripod TRI128
- control unit Timy3 W
- 2 x push button 023-02 for the lap counter
- distributor central with integrated charger VELO-PB
- distributor red VELO-PA
- distributor green VELO-PC
- distributor sprint VELO-MD
- distributor start 200 m VELO-ME
- distributor timing VELO-M-F
- distributor split time 100 m VELO-MG

The CycleStart does not include any cables.

CYCLING - TRACK CYCLING

CycleStart



Display Board CS-DB

three electromagnetic digits, yellow on black ground, red/green light for count-down and cycle identification, height 15 cm, max. reading distance approx. 70 m, including integrated countdown loud-speaker, power-pack (battery and charger)

Tripod TRI128

with a max. height of 128 cm



Control Unit Timy3 W

control unit for display board (count-down function and lap counter), as well as manual timing device



e.g. distributor VELO-M-A



e.g. distributor VELO-P-C

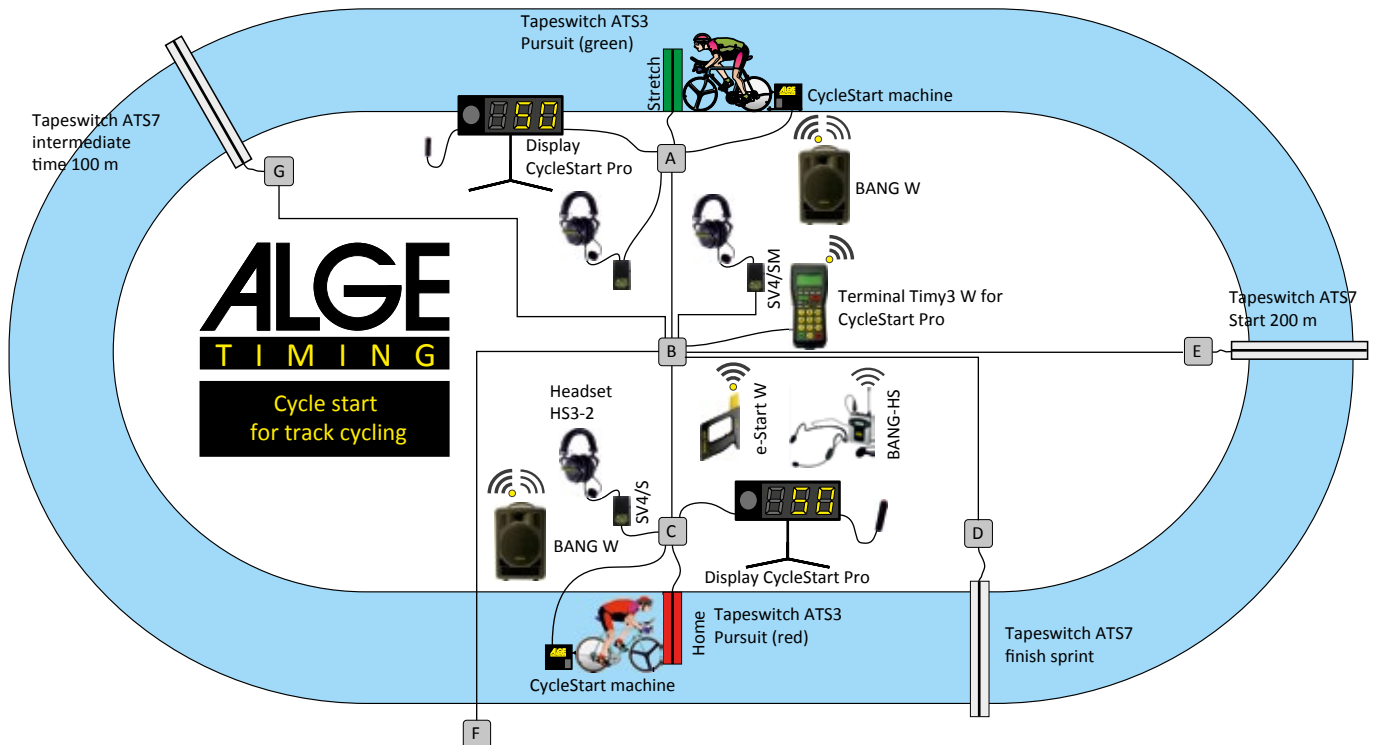



CYCLING - TRACK CYCLING

Track Cycling Startmachine ST-BSM1

The ST-BSM1 startmachine is particularly suitable for the start of pursuit races, as it releases the saddle bar holder of the cyclist on the impulse of the start device and simultaneously starts the timing system.

It is a variably adjustable pneumatic device with air compressor, which meets the most demanding requirements.

- start output (banana sockets)
- start input (banana sockets)
- connection for pressurized air compressor
- display instrument for pressurized air
- close button for the rear brake
- open button for the rear brake
- close button for the saddle holder
- open button for the saddle holder
- button for wheel support
- two operating switches
- brake for rear wheel
- brake for saddle
- wheel support for rear wheel (prevents slipping)
- internal 12V lead acid rechargeable battery
- adjustable inclination (angle of inclination)

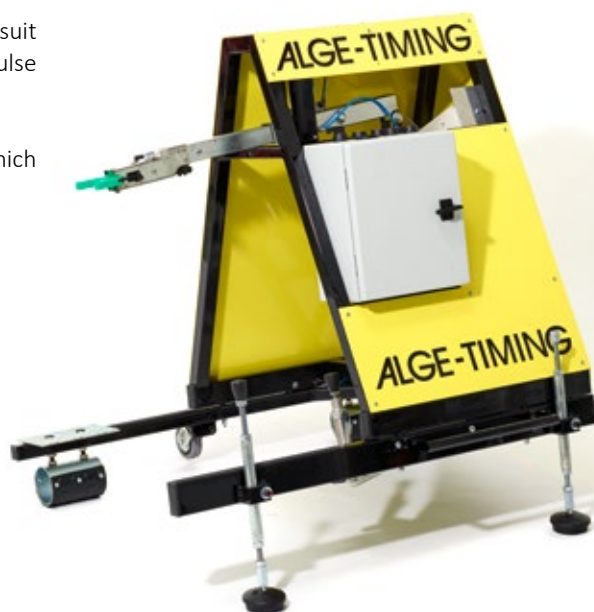

CYCLING - TRACK CYCLING

Track Cycling Startmachine ST-BSM1



control elements



saddle bar holder



pneumatic compressor



bicycle is held on the saddle and the rear wheel, as well as supported by the rear wheel





CYCLING - MOUNTAIN BIKE

Downhill

In the downhill, the start can be carried out using a Startclock ASC3 and a photocell or a tape switch. A photocell adapter LA5 is recommended for activating the photocell or the tape switch, and for communication with the timing operator.

In the finish, a photocell stops the time from the TdC8001 timer and simultaneously controls the scoreboard.

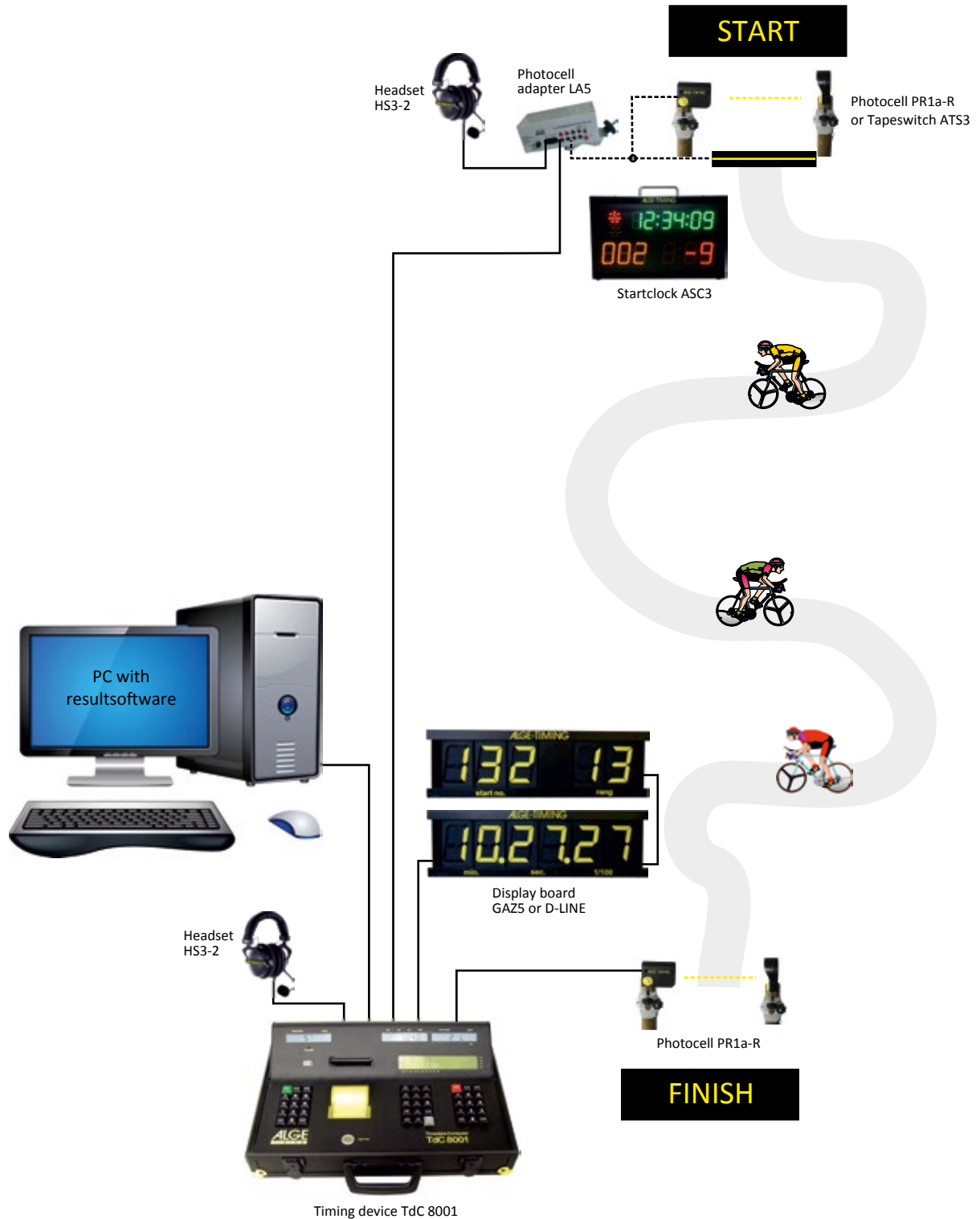

CYCLING - MOUNTAIN BIKE

Cross Country and Speed



Mountain Bike - Cross Country

The start signal is given with the electronic start gun e-Start and the laps are counted with a lap counter at the finish line.

A display board indicates the run time measured by the TdC8001. A photocell stops the time in the finish and controls the recording of the photo finish.

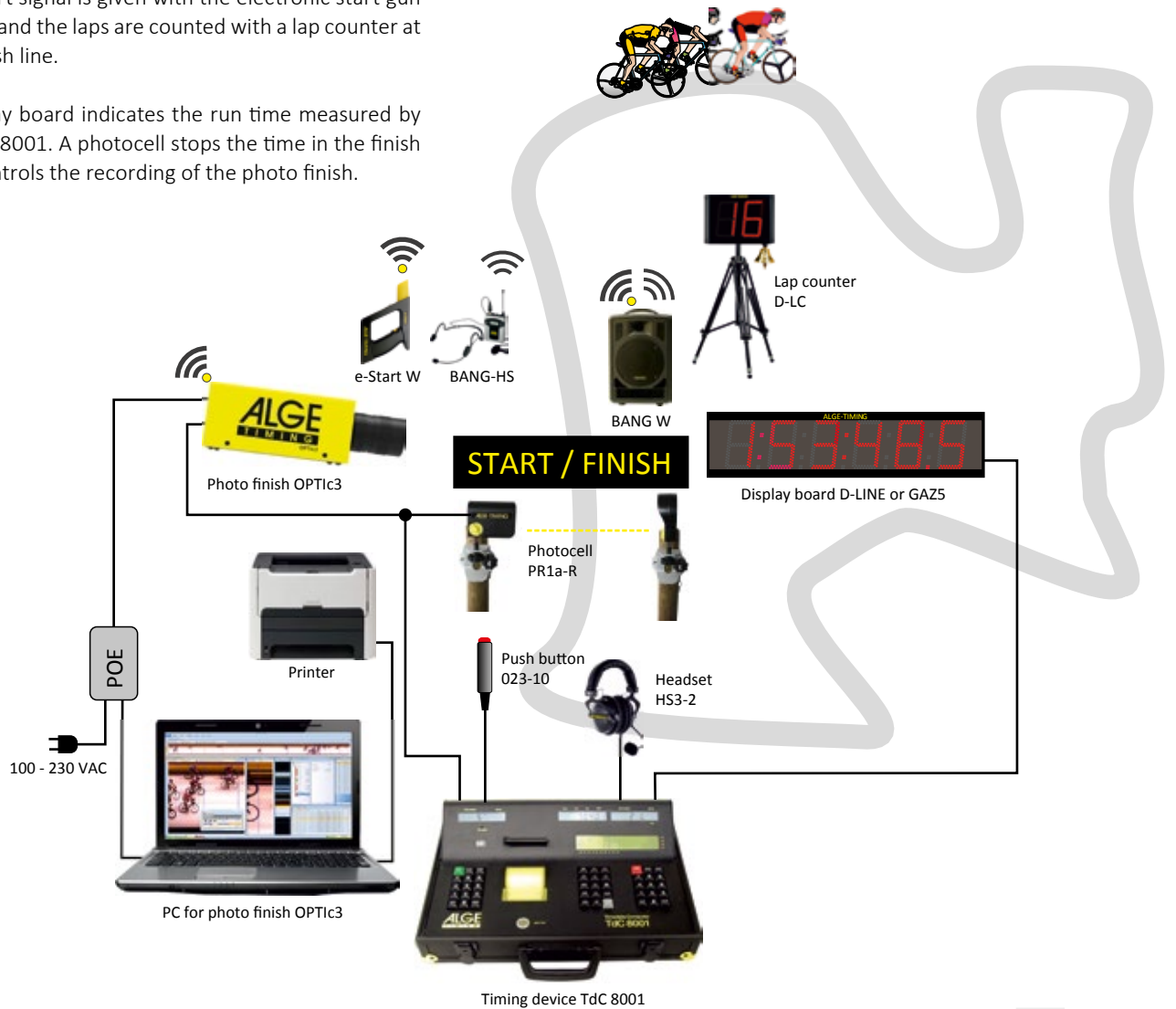

Mountain Bike - Speed

For the speed measurement, two photocells are required, which are set up exactly at a given distance. The TdC8001 or the Timy3 measure the exact speed and shows it on the display board.

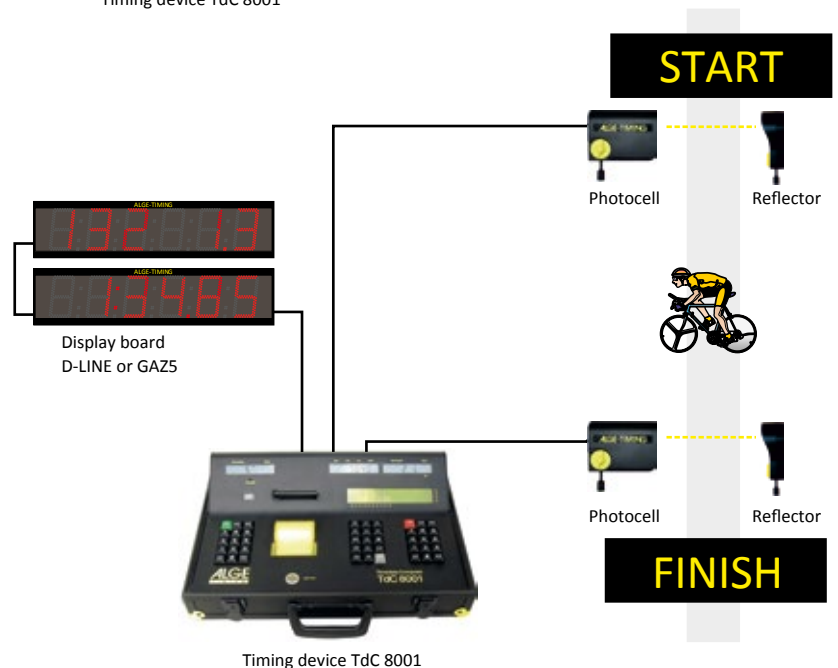



SHOW JUMPING



SHOW JUMPING



Timing systems are used in equestrian sports at events of all levels. For many years, ALGE-TIMING has been one of the world's leading manufacturers of timing systems certified by the FEI (International Equestrian Federation).

The new wireless system WTN (Wireless Timing Network) once again made a leap forward, since the systems without cable connections can be set up faster and is extremely reliable.



CERTIFICATE

This is to certify that the following timing devices manufactured by

ALGE-TIMING GmbH

have fulfilled the requirements established by the FEI for the homologation of timing systems and have therefore been approved for use at international Jumping events. This certificate is only valid for the models listed hereunder:

| Timers | Photocells | Wireless Transmission |
|-----------|------------|-----------------------|
| TdC 8001 | RLS 1n | TED-TX10 / RX10 |
| Timy PXE | RLS 1nnd | TED-TX400 / RX400 |
| Timer S4 | PR1a | WTN |
| Timy2 PXE | PR1aW | |
| Timy2 XE | | |
| TdC 8000 | | |
| Timy3 WP | | |

Fédération Equestre Internationale
HM King Hussein I Building
ch. de la Joliette 8
1006 Lausanne
Switzerland

John P. Roche
Director, FEI Jumping

FEI certified

At the international events of the Fédération Equestre Internationale (FEI), only certified timing systems are permitted. For this reason, all devices that ALGE-TIMING offers for equestrian are FEI certified.



SHOW JUMPING

Time Measuring System with TdC8001

Various timing systems are suitable to handle show jumping tournaments, which are adapted to the individual circumstances for tournaments of different levels.

Especially the timing system with the proven TdC8001 and radio system WTN is very popular and suitable for events of any level.

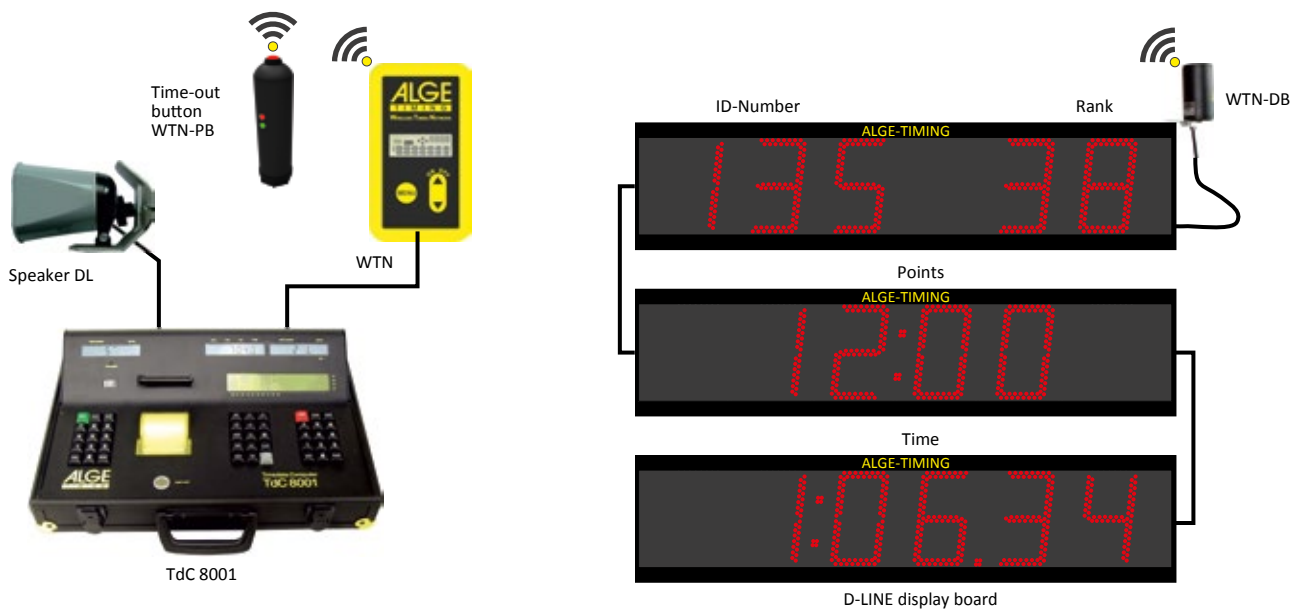
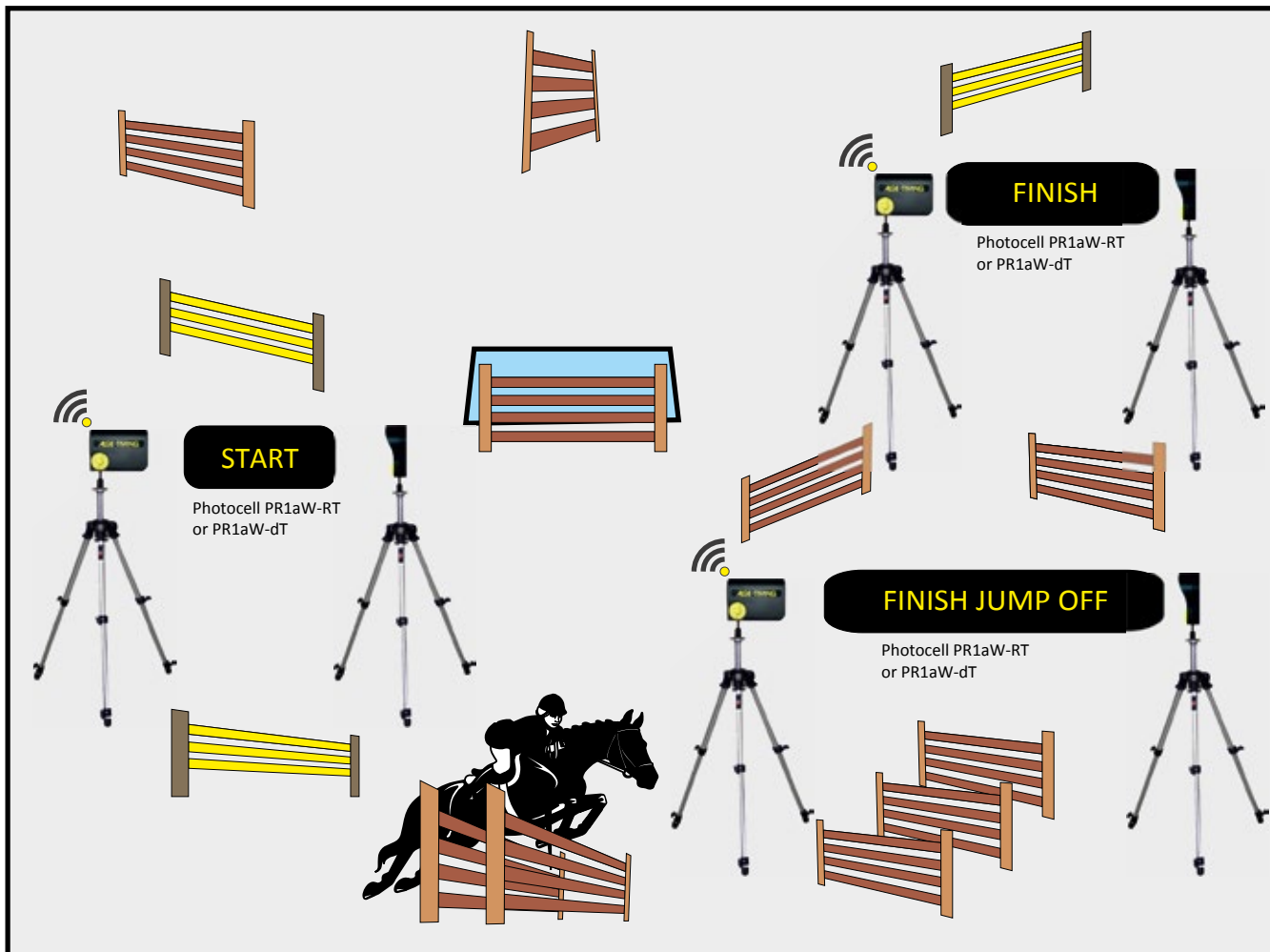

SHOW JUMPING

Timing System with Timy3



The radio system Wireless Timing Network WTN is built into the timing device Timy3 WP and photocell PR1aW. This allows to set up the timing system fast and easy.

The display boards are controlled via the WTN radio system and the timing via the PC with an evaluation software, which also makes it easy to print the competition lists, such as start and ranking lists.

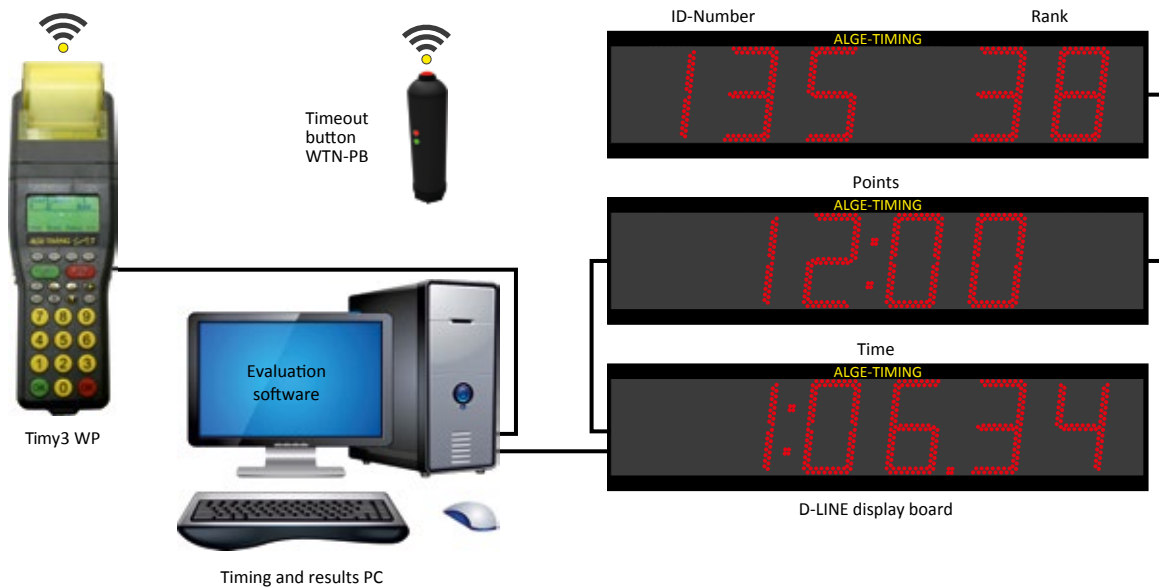
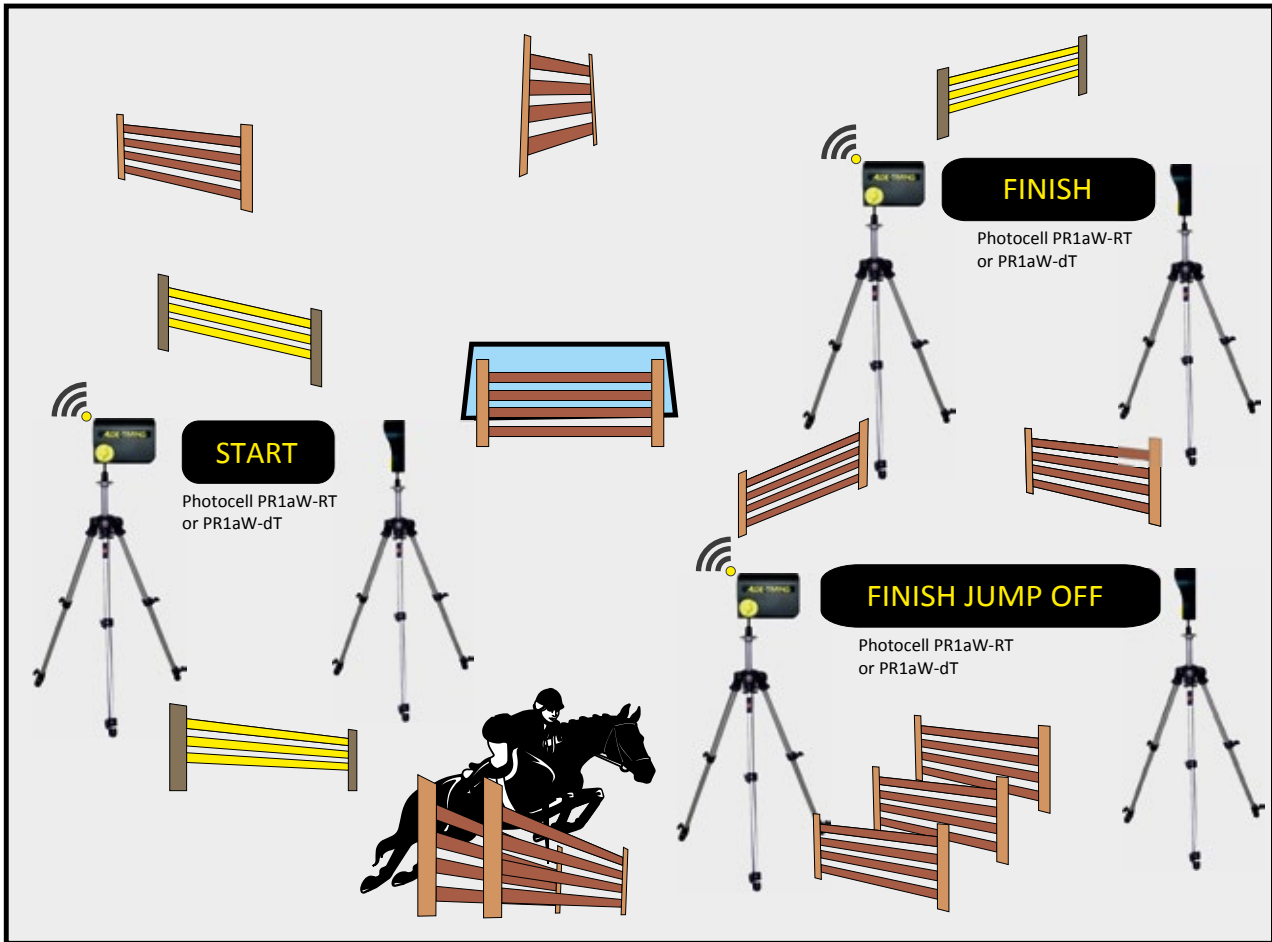



SHOW JUMPING

Components of the System



Time Data Computer TdC8001

The professional equipment with special programs for show jumping, with battery operation and integrated protocol printer, on which the entire show jumping is processed. Penalty points can be entered and time penalty points are automatically calculated.



Timy3 WP

Compact, timing device with the highest precision, which is ideally suited for working with a PC with evaluation software because it is equipped with a USB interface, an integrated protocol printer and an integrated wireless module WTN.



Wireless Timing Network WTN-WS

The WTN is a universal wireless network for wireless timing and data transmission to the PC or the display board.



Photocell PR1a-RT

photocell with combined transmitter-receiver unit and reflector, for distances up to approx. 25 m, with the integrated WTN wireless module



Photocell PR1a-dT

photocell with transmitter and receiver for long distances of up to 100 m, with integrated WTN wireless module



WTN-PB Wireless Push Button

The judge can use this radio push button to control the time-out. With the integrated WTN it is independent of cables and he can move freely.



Push Button 023-02

alternative with cable to trigger the time-outs



Loudspeaker

The TdC8001 outputs the timing signal in an acoustic way for start or countdown through this speaker.



Radio Receiver WTN-DB

radio receiver for display boards such as D-LINE or GAZ5 with integrated WTN



Display Board GAZ5

The GAZ5 is an electromagnetic seven-segment display boards that can display the time, points, ID-numbers, and rank with digit heights of 15 or 25 cm.



Display Board D-LINE

The D-LINE is a seven-segment LED display board that can display the time, points, ID-numbers, and the rank, with digit heights of 15, 25, 45, 60 or 100 cm.



Display Board D-RTNM

The D-RTNM is a matrix display with red LEDs in various sizes for displaying the name of the rider, horse, advertising, graphics, animations or a running text.



Matrix Display Board and Video Wall

Matrix display boards and video walls are available in all sizes, upon request.

SHOW JUMPING

Endurance



Likewise, for endurance competitions the timing device TdC8001 is perfect. We recommend the Startclock ASC3 for an orderly and exact starting procedure. If start and finish are close to one another, the timer can keep contact with the starter

by headset. In case of short starting intervals it is advantageous installing a further headset about 200 m before the finish in order to announce the horses about to finish.

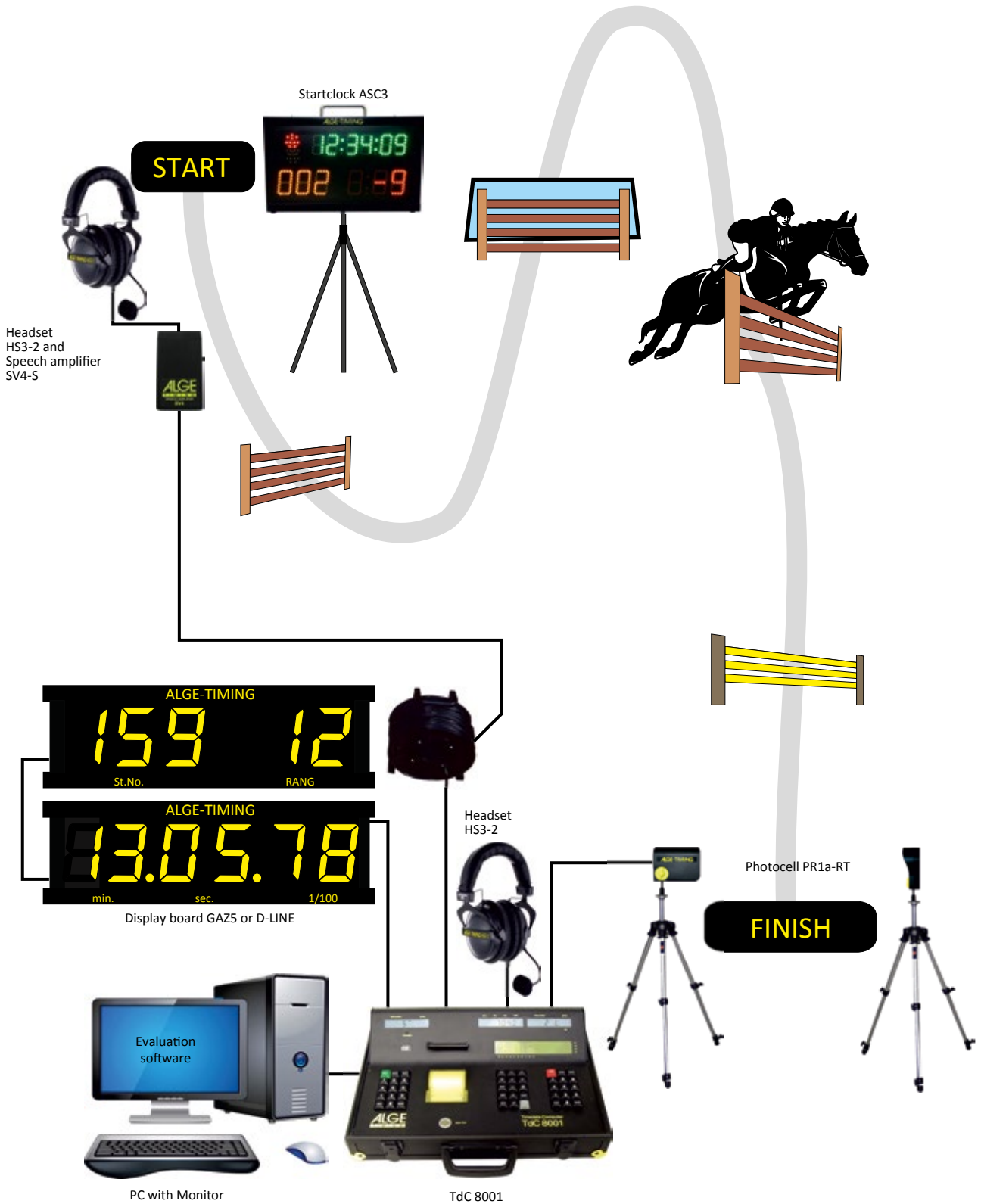



HORSE RACING

Horse race courses may have one or more tracks. When using only one OPTIC3 Photo Finish camera, it must be aligned to the particular finish line used. It is also possible to use one

camera per finish line. In addition, the tracks can be equipped with photocells, radio transmission, display boards and video broadcasts.



photo finish pictures from OPTIC3 (gallop)



photo finish pictures from OPTIC3 (trotting)

HORSE RACING

Timing Setup



Each horse race course has its own specific features and is shown in the example illustration with two tracks. The system can be customized to suit every horse race course.



Display board e.g. type D-HS300-21N-P7-8x144

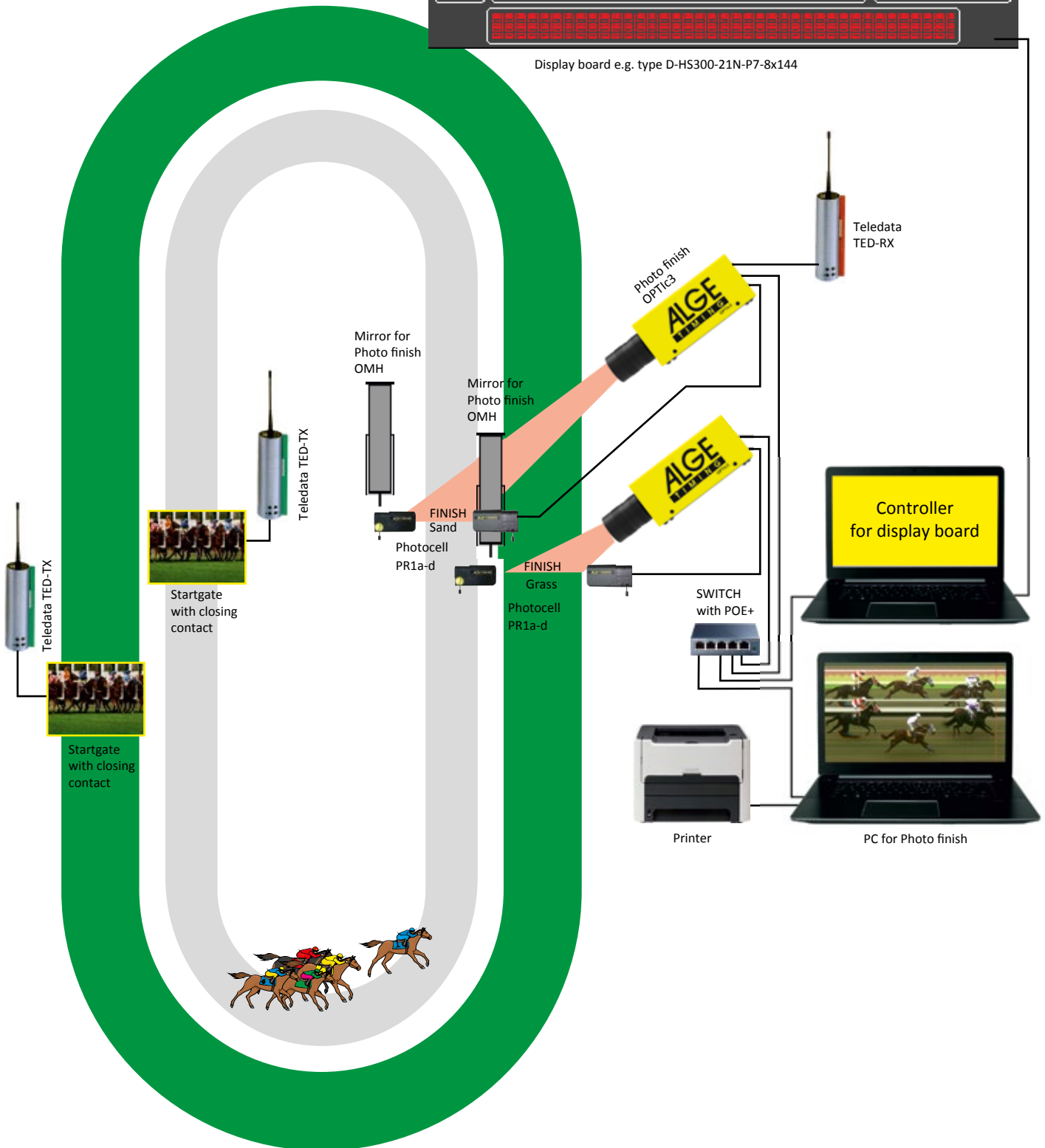



HORSE RACING

Accessories

Photocell PR1a-d

photocell with transmitter and receiver for long distances (up to 100 m)

Photocell Housing PB4

to protect the photocell from dirt, dust and weather influences

Heated Photocell Housing PB4H

An integrated heater protects the photocell from misting and icing. The integrated power supply feeds the photocell.

Radio Teledata TED400

For wireless transmission of the start signal to the timing device. This allows the start from any point of the horse track (distances up to 4.5 km with a clear view).

Photo Finish OPTic3

The photo finish camera records the finish arrival of the race and an evaluation of the order of the horses is possible.

Mirror for Photo Finish OMH

Through the mirror, you can see the opposite side on the photo finish, which gives the decisive result in the evaluation of hidden horses.

OMH: mirror without heating

OMH-H: mirror with heater for racing at cold temperatures



photocell PR1a-d



Teledata TED400



photo finish OPTic3



mirror for photo finish

HORSE RACING

Display Boards



Just as unique as any horse race course are the display boards that are used: The model shown below is a globally installed solution that convinces with simplicity and clarity. However, individual special solutions with full-matrix display boards are also very popular in the riding sports.

Display Board D-HS300-17N-P7-8x144

with interface for ALGE-TIMING timing devices. Control of the display boards via PC software or ALGE-TIMING console with PC keyboard including control console for "steward room".

Interfaces: RS485, RS232 and Ethernet

Digit height: 300 mm

1. Line: with 17 numeric digits (digit height = 300 mm) to display the race number (2 digits), horse number of the first 5 places (2 digits) and time (5 digits for minutes, seconds and 1/100)

2. Line: with a full matrix of 8 x 144 pixels (at least 25 characters), each pixel consists of 7 extra bright red LEDs, animated texts can be displayed (e.g., scrolling).

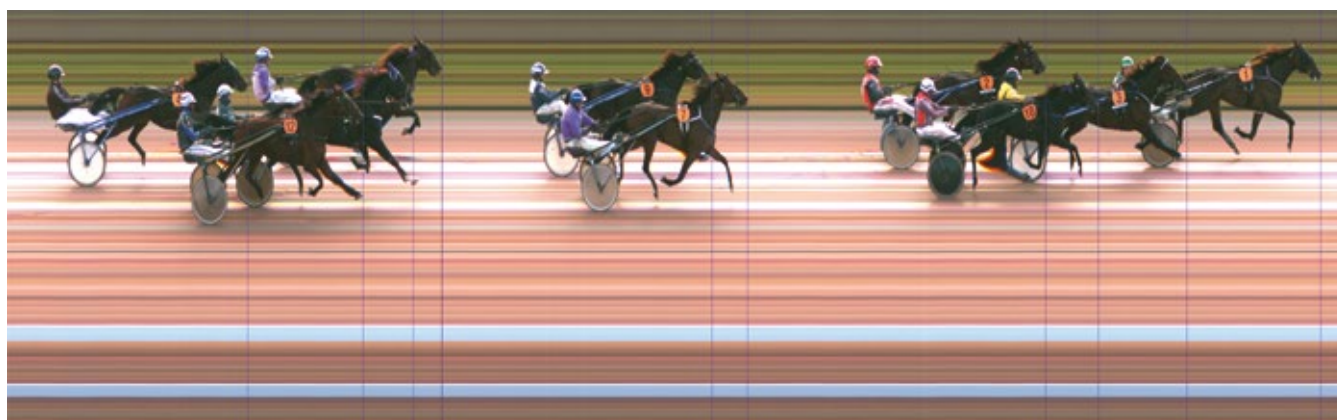



SWIMMING



SWIMMING



Based on years of experience in timing for different sports, ALGE-TIMING has developed exclusive solutions for timing at swimming competitions. Thanks to the robust construction

and the processing of high-quality materials, ALGE-TIMING guarantees reliable results and an above-average life span of the system.

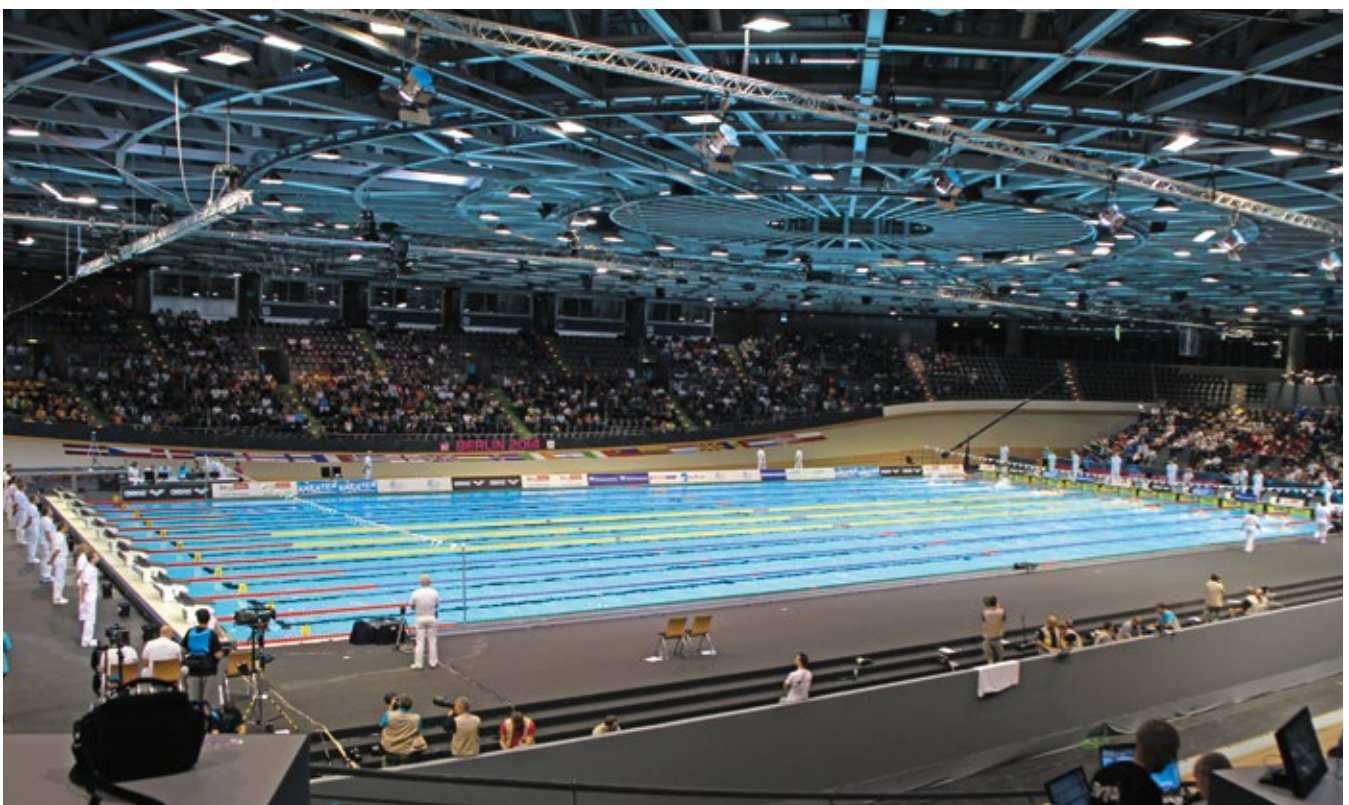



SWIMMING

Semi-Automatic Timing System

A semi-automatic timing system uses manual finish push buttons for each lane. The result of the timing, as well as the ranking of the participants, can be determined in real time and is printed on the spot.

The manual push button is connected via a special cable MC8-SWIM. The start signal is given, for example, via the loudspeaker SPP and the results can be tracked via various display boards connected to the Timy3 WP.

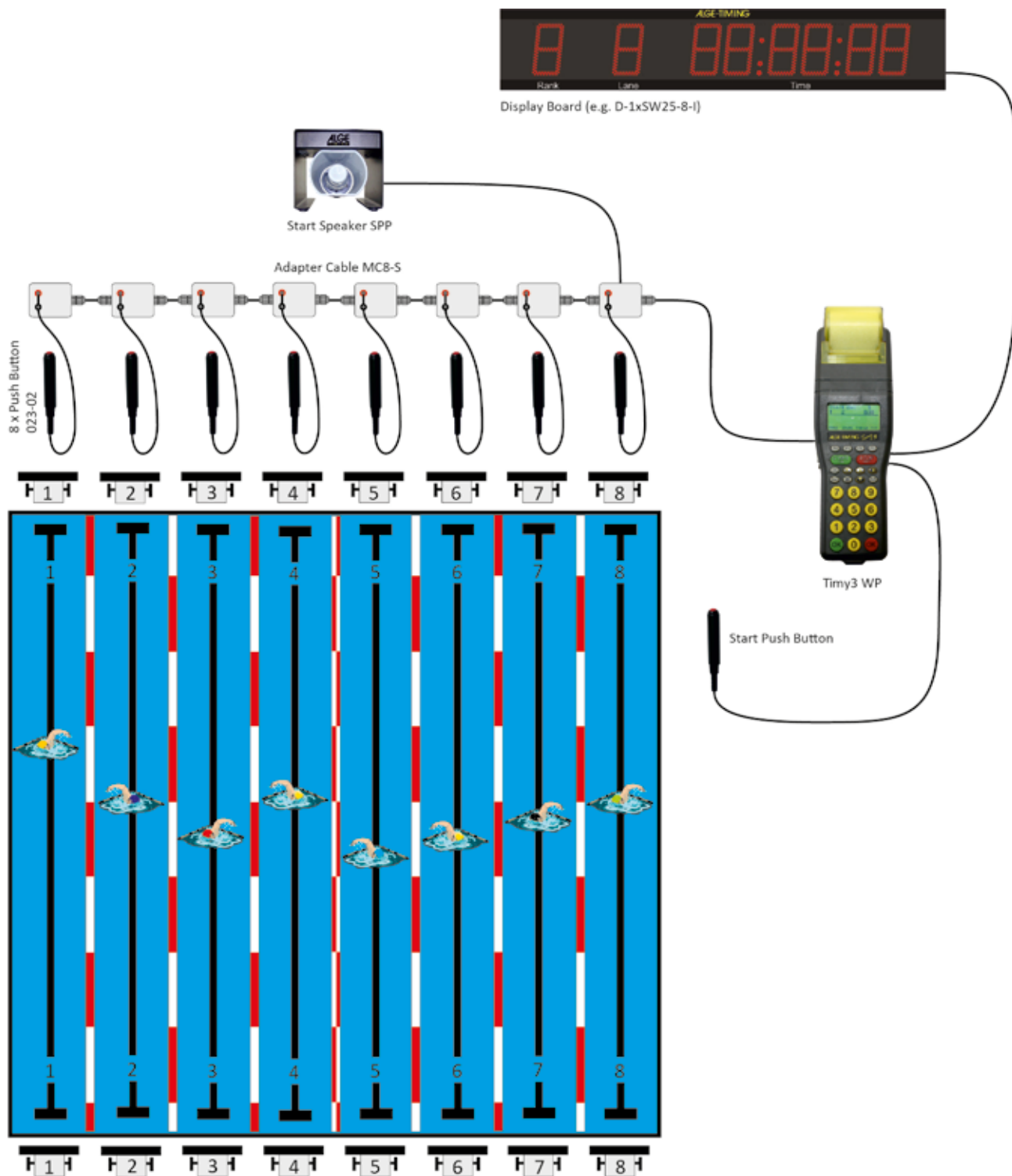

SWIMMING

Semi-Automatic Timing System with Radio



New in the swimming sport is the WTN radio system, which is very successful in other sports. ALGE-TIMING offers a semi-automatic radio system in which every lane has a radio push button WTN-PB with a separate timing channel.

timing for up to eight lanes. Several display boards can be connected to the Timy3 WP at the same time. The ranking list is created immediately and printed on the spot, when the swimmers arrive at the finish.

The WTN-PB manual push buttons are equipped with the ALGE-TIMING Wireless Timing Network, which allows a wireless

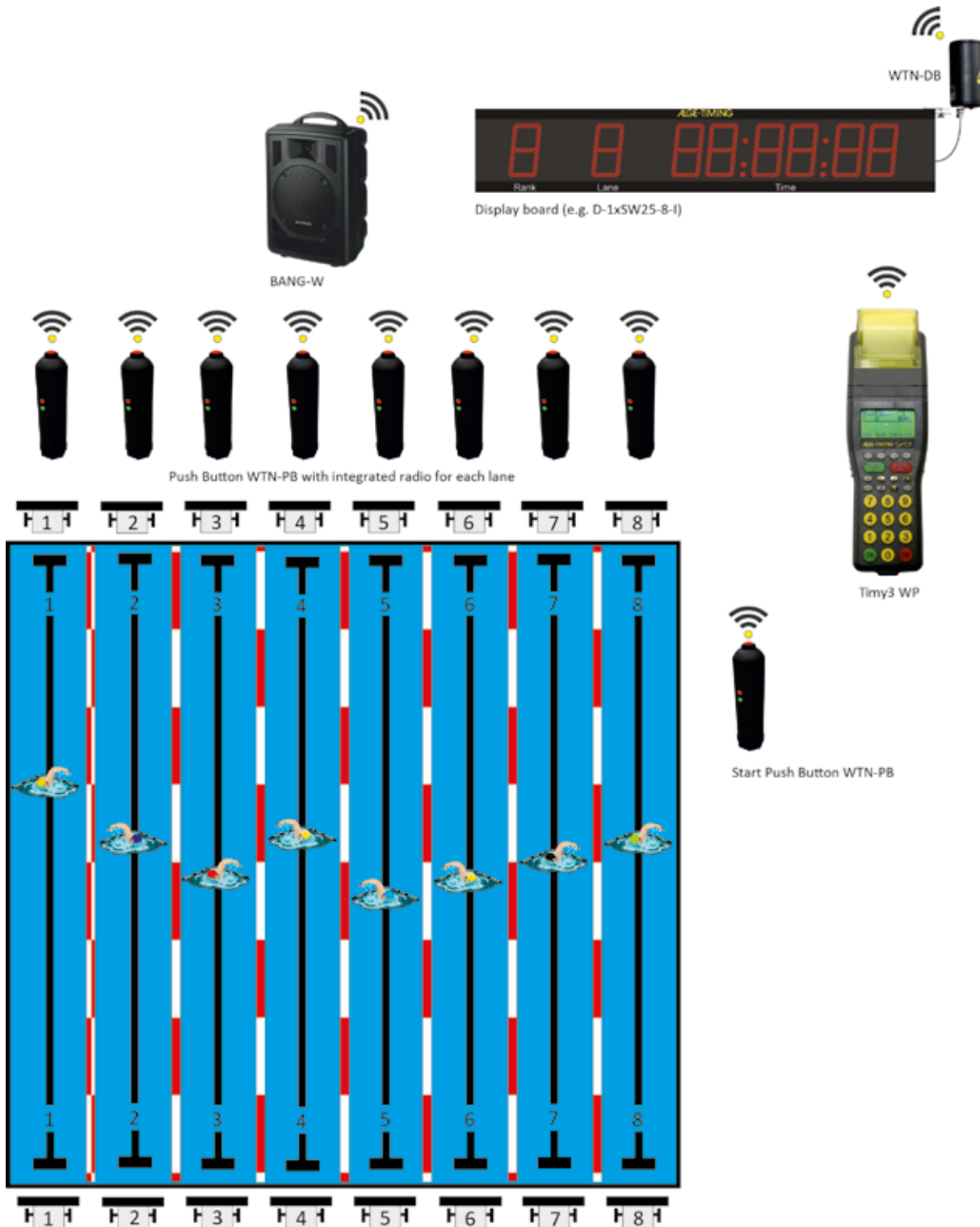



SWIMMING

Automatic Timing System

With a fully automatic timing system, the swimmer of each lane stops its time by pushing against a touchpad. In addition to the touchpad, it is possible to equip each lane with up to three manual push buttons. At the start each lane has a speaker to give oral comments to the swimmer and to output the start signal.

The fully automatic time measuring system can be easily extended for big events.

In addition, the new OPTic3 provides a very valuable video backup system with 100 pictures per second.

ALGE

TIMING

Swimming 10 lanes
with video backup and
video screen

| 400 M MEDLEY - MEN | | | | | | |
|----------------------------------|--|--------------------------|-----|-------|---------|---|
| HEAT 2 OF 4 | | | | | | |
| WR 4:03.84 CR 4:09.59 ER 4:06.16 | | | | | | |
| 1:40.5 | | | | | | |
| 0 | | Nikola DIMITROV | BUL | 34.30 | 1:36.71 | 7 |
| 1 | | Alexander KUDASHEV | RUS | 35.30 | 1:32.14 | 1 |
| 2 | | Alpkan ORNEK | TUR | 34.96 | 1:35.85 | 6 |
| 3 | | Jeremy Marc DESPLANCHES | SUI | 33.10 | 1:33.37 | 3 |
| 4 | | Christoph MEIER | LIE | 35.73 | 1:33.41 | 4 |
| 5 | | Diogo Filipe CARVALHOPOR | POR | | | |
| 6 | | Pavel JANECEK | CZE | 34.36 | 1:32.92 | 2 |
| 7 | | Bogdan KNEZEVIC | SRB | 35.43 | 1:34.83 | 5 |
| 8 | | Uladzimir ZHYHARAU | BLR | 36.79 | 1:37.37 | 9 |
| 9 | | Anton GONCHAROV | UKR | 36.32 | 1:37.24 | 8 |

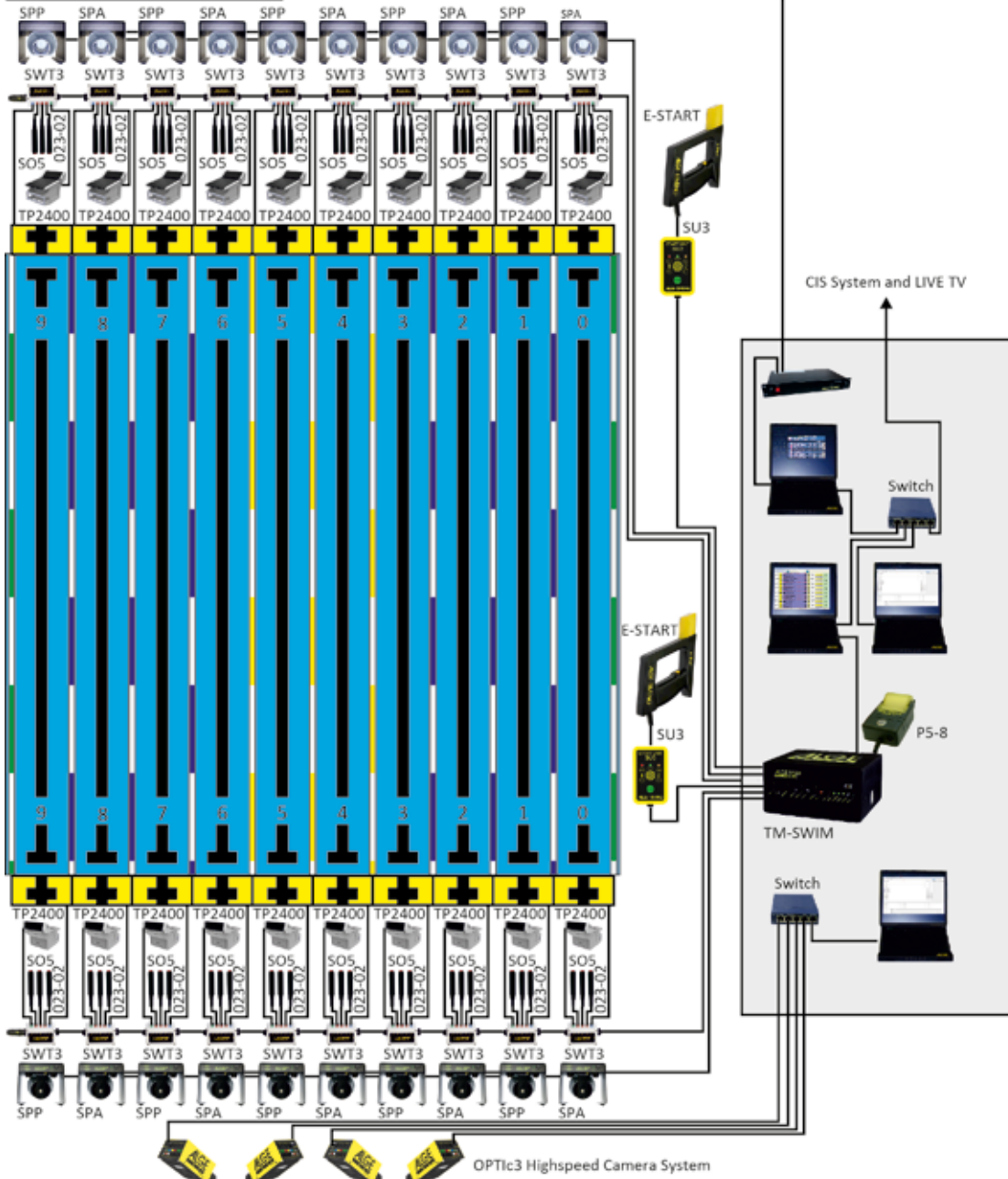

SWIMMING

Automatic Timing System



SwimTime with TimeManager TM-SWIM

New technologies make timing easy.

The TM-SWIM has been developed especially for the extreme requirements of swimming. The TM-SWIM is the first timing device for swimming that has a USB interface to meet the requirements of modern PCs. It has an integrated audio amplifier as well as backup batteries and combines know-how, state-of-the-art electronics and the sturdy design by ALGE-TIMING.

All timing functions are executed and stored directly in TM-SWIM. The PC is only needed to capture a competition in the system and is then used to visualize and control the TimeManager. The TM-SWIM runs the race fully automatically and sends the times simultaneously to the PC software SwimTime, so that the user can follow the competition on the clearly organized user interface.



Facts of the Timing System ALGE SwimTime

- PC-based timing system
- USB Interface
- user-friendly control
- possibility to control a maximum of 16 lanes on both sides
- optical and acoustic control over all lanes
- connection possibilities for 1 touchpad, 3 manual push buttons and 1 relay-start-pad per lane (5 independent timing channels per lane and side)
- integrated battery backup also works without a PC for 4 hours regardless of the network
- integrated loudspeaker system
- possibility of talking between the starter and the timing operator with headsets
- false start warning on the monitor
- warnings if the time difference between the touchpad and the manual impulse is too big
- warning for unregistered touches
- reliable and robust touchpad
- collection of statistical data such as: Reaction time, block-off time, pressure duration on the starting block and touchpad
- conformity: FINA, SSCH, AAU, NCAA and LEN



SWIMMING

Automatic Timing System

Technical Data

Range of measurement: 23 hours, 59 minutes, 59.9999 seconds
 Time reference: TCXO 10,000 MHz (temperature-compensated quartz oscillator)
 Accuracy: TCXO, +/- 0.1 ppm (+/- 0.00036 s/h)
 Temperature range: -25 °C to +50 °C
 Power supply: internal: 12 V gel cell battery
 external: 100 - 240 VAC, 50/60 Hz, optional 12 - 18 VDC
 Interfaces: USB interface for PC or video
 RS232 interface for PC or video
 2 x RS232 interface for protocol printer
 2 x RS232 interface for display board
 RS485 for display board
 Other connections: 2 x timing bus for start and turn side
 2 x speaker active
 2 x SU3 (start unit)/FLASH XL
 start (banana socket)
 audio line in
 audio line out
 Controller: microphone
 headset
 audio in
 total volume



SWIM Terminal SWT3

A swim terminal is required for each lane and side. All SWT3 are identical and have no internal numbering. When switched on, the TM-SWIM automatically determines how many lanes are connected to the system and numbers them, according to the specifications.



Each swim terminal has five independent channels:

- 1 x touchpad
- 3 x push button
- 1 x relay-start-pad

Protocol Printer P5-8

Online log of all impulses

- competition number and run number
- name of the heat
- times (start, start block, touchpad, manual push-button)
- times outside a run are printed in the time of day format
- printing speed: 5 lines per second



SWIMMING

Automatic Timing System



SwimTime with TimeManager TM-SWIM

PC Software

The ALGE-TIMING PC software SwimTime manages all times and has optimal interfaces to the most common evaluation software in swimming. By dividing the software into timing and evaluation programs (Meet Management software) one can measure the time on one PC, while using one or more other PCs to take care

of the tasks of the organizational work in the race office, e.g. run scheduling, printing lists, etc.

SwimTime is compatible with all current Microsoft Windows versions (Windows XP, Vista, Windows 7, Windows 8 or Windows 10).

Time Measuring Program

The screenshot shows the SwimTime V6.5.62 software interface. It features a menu bar at the top, a competition selection dropdown, and a list of participants with their names, clubs, and lane numbers. The interface displays lap times, total times, manual times, and stops for each participant. Annotations on the left side identify the menu bar, competition selection, participant data, blocking time of the start side, track number, and status bar. Annotations on the right side identify lap time, total time, manual time, stops, blocking time for the reverse side, lane with waiting swimmer (not started yet), and free lane.

| Track | Participant | Lap 1 | Lap 2 | Lap 3 | Lap 4 | Total | Manual | Stops |
|-------|--|----------|----------|-------|----------|----------|--------|-------|
| 1 | Andrea Bruder Schwimmclub Aarefisch Aarau, SUI | 00:34.34 | 02:11.62 | +0.79 | 02:11.73 | 04:56.46 | 4:00 | 0 |
| 2 | Maxime Bradley Renens-Natation, FRA | 00:32.14 | 02:04.12 | +0.80 | 02:04.20 | 4:40.26 | 4:00 | 0 |
| 3 | Elias Mehrdad Lausanne Natation, SUI | 00:32.01 | 02:00.33 | +0.81 | 02:00.49 | 4:33.33 | 4:00 | 0 |
| 4 | Jean-Baptiste Febo CN Plan-les-Ouates, SUI | 00:29.28 | 01:54.03 | +0.81 | 01:54.14 | 4:17.45 | 4:00 | 0 |
| 5 | Marc-Luca Ramsebner Schwimmklub Bern, SUI | 00:30.71 | 01:57.54 | +0.88 | 01:57.62 | 4:16.67 | 4:00 | 0 |
| 6 | Alexandre Haldemann Natation Sportive Genève, SUI | 00:32.26 | 02:00.63 | +0.88 | 02:00.64 | 4:33.54 | 4:00 | 0 |
| 7 | Jeremy Desplanches Genève Natation 1885, SUI | 00:00.00 | 00:00.00 | - | 00:00.00 | 00:00.00 | 0 | 0 |
| 8 | Free lane | 00:00.00 | 00:00.00 | - | 00:00.00 | 00:00.00 | 0 | 0 |



The timing software works with neatly organized, animated symbols. This simplifies the operation.

- adapted for easy cooperation with evaluation software
- optical representation
- easiest operation
- free software updates
- battery backups
- easy understandable protocols
- expandable up to 16 lanes
- participant data can also be seen at the timing software
- many helpful control functions





SWIMMING

Automatic Timing System Components



TimeManager TM-SWIM

The high-tech device TM-SWIM collects and stores all Flash ROM data. It has galvanically isolated interfaces, acoustic part and synchronous input and output.



SWIM Terminal SWT3

The terminals are connected by a cable. A terminating plug SWT-END must be used at the last terminal. There is no fixed numbering! Includes connections for 1 TP1890/2400 touchpad, 3 separate manual push buttons 023-02 and 1 starting block or 1 relay-start-pad.



Start Unit SU3

with integrated microphone and on/off switch for the microphone, volume control and start button



Speakers SPA and SPP

integrated gel-cell battery and speech amplifier. A SPA also controls an SPP.



LED Display Boards

are available in various technologies as a numeric seven-segment or matrix scoreboard.



Touchpad TP1890/2400

The touchpad is one of the main components in the timing system. The quality of this component determines the success of the entire system. The closed design of the touchpad (frame with backside of stainless steel 1.4404) offers maximum protection and reliability. The touchpads are available in various sizes:

- TP2400: 2,400 x 906 x 9.5mm
- TP1890: 1,890 x 906 x 9.5mm

Custom sizes are available upon request.



Manual Push Button 023-02

stable, water-proof construction, cable length 2 m.



Starting Block SO5

The SO5, made of plastic, is characterized by a modern design and an adjustable foot rest (chromium-reinforced).



Relay-Start-Pad SWR7

The solution for existing starting panels. Mobile use on most starting blocks without drilling or other mechanic changes.



Backstroke Start Aid BSA

for a perfect start when backstroke swimming. The ALGE-TIMING BSA fits all starting blocks.

All components are compliant with the rules of FINA, SSCH, AAU, NCAA and LEN.

SWIMMING

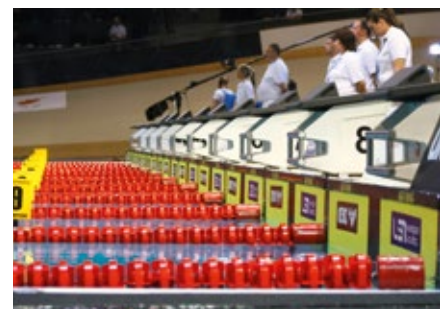
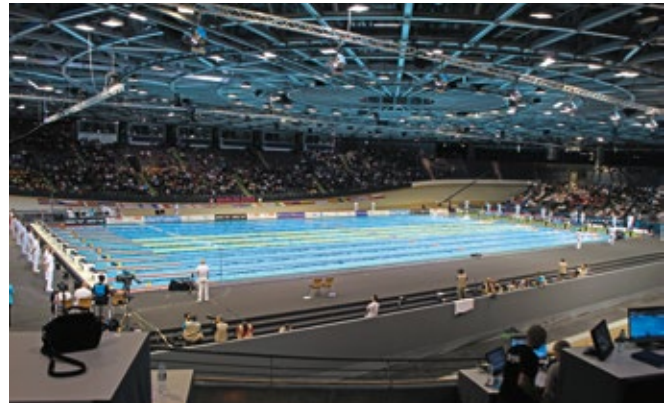



SWIMMING

Touchpad TP2400 / TP1800 / TP980

The touchpad TP is one of the key components for a successful swimming timing system. The closed construction of the stainless steel frame makes it rugged and protects the integrated tape switches. The stainless steel is of best quality and made for the use in swimming pools where you have aggressive chlorine water.

Four tape switches that cover the touchpad over the full length make sure that wherever the swimmers touch, the touchpad is sensitive for timing impulses at any spot.

The innovative and patented touchpad models have a surface with lamellas and an exemplary grip for the swimmers. Many experiments and tests were made with different materials to reach this goal. A lamella designed by ALGE-TIMING and produced for ALGE-TIMING with a special injection molding machine has small bumps to guarantee the optimal grip.

Furthermore, each touchpad has hundreds of small holes that allow the water to float through it. For the swimmer, this

means fair water flow conditions in overflow swimming pools for all lanes.

By using new materials and a stainless steel case with holes the complete touchpad is about 30% lighter than previous touchpads produced by ALGE-TIMING.



All the benefits at a glance:

- special anti-slip surface for optimum grip
- four tape switches for consistent sensitivity
- no false timing due to water splash or waves
- patented water flow during the competition for fair conditions
- stainless steel housing 1,404
- robust construction
- easy banana plug connection with the timing system
- compatibility with most timing systems (NO contact)
- three standard models (TP2400, TP1890, TP980)
- customer-specific dimensions available upon request
- special transport trolley for storing up to 12 touchpad



SWIMMING

Touchpad TP2400 / TP1800 / TP980



A stainless steel back plate protects the touchpad against damage (high-quality stainless steel quality for use in swimming pools).

The secret of the incomparable grip are the specially designed lamellas from ALGE-TIMING. They have a rough surface with thousands of very small bumps.

Unlike other touchpad, the water flows through the ALGE-TIMING touchpad and guarantees optimal flow conditions in overflow basins. Other touchpad block the water flow at the ends and cause cross flows. With the patented construction of the ALGE-TIMING touchpad, fair conditions prevail for all participating athletes.

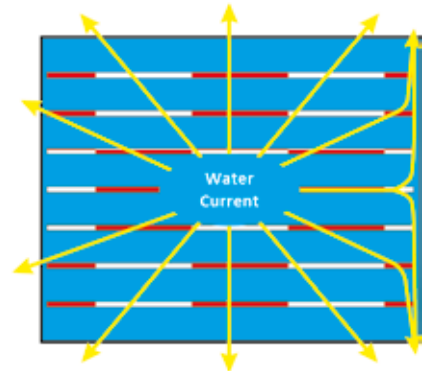
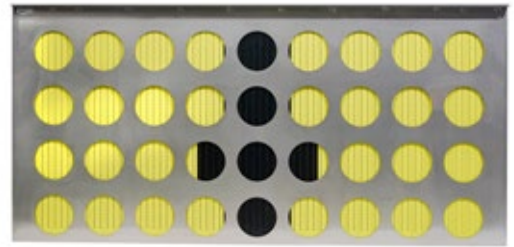

The water flow with the new ALGE-TIMING touchpad is shown on the left side of the sketch.

The right side shows the water flow with the touchpad closed.

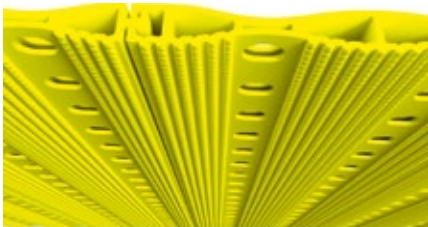

Touchpad Models

TP2400 for swimming pools with a lane width of 2.5 m

stainless steel housing with steel 1.4404 and PVC slats 2,400 x 906 mm, max. 9.5 mm thick in active area, 19 kg

TP1890 for swimming pool with a lane width of 2 m

stainless steel housing with steel 1.4404 and PVC slats 1,890 x 906 mm, max. 9.5 mm thick in active area, 14 kg



TP980 for training

stainless steel housing with steel 1.4404 and PVC lamellas 980 x 906 mm, max. 9.5 mm thick in active area, 8 kg

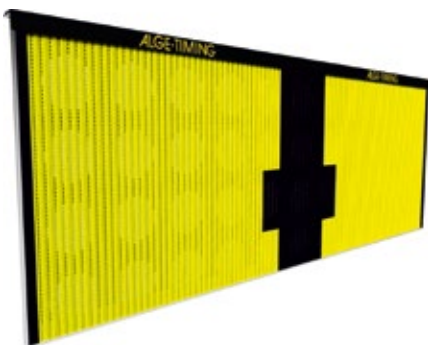



SWIMMING

Starting Block

The ALGE-TIMING starting block SO5 is made of easy-care plastic and has an integrated fault starting plate as well as an adjustable foot rest.

With the SO5, it can be checked whether the swimmer is jumping too early in a competition. In conjunction with the latest SWT3, it is even possible to measure the jump duration time.



Starting Block SO5

The SO5 is made of plastic (polyethylene) and supplies relay exchange times, block-off times and reaction times. The adjustable foot rest can be engaged by the swimmer in 6 positions, thus enabling an optimal step start. For public operation, the foot rest can be removed. The SO5 is designed for continuous use in indoor and outdoor swimming pools.

New: improved surface for optimum grip

Technical Data

Measuring system: integrated sensor for reaction time and jump duration
Foot rest: 6-stage adjustable, removable without tools
Made of: plastic, chrome-steel reinforced
Dimensions: 740 x 560 x 400 mm
Weight: 24 kg
Conformity: FINA, SSCH, AAU, NCAA and LEN rules



Relay-Take Off Sensor SWR7

The SWR7 is made of high-quality stainless steel 1.4404 and provides relay exchange times, block-off times and reaction times. The SWR6 must be adapted to the existing start base and fastened with screws to the base. On the model SWR7M, a tensioning strap can be used instead of the screws. The particularly slip-resistant surface developed by ALGE-TIMING is indestructible and does not change its properties even after many years. The adjustable foot rest can be adjusted easily by the swimmers.

Technical Data

Measuring system: integrated sensor for timing
Made of: stainless steel 1.4404, surface treated
Dimensions: 740 x 560 x 40 mm
Weight: 26 kg
Conformity: FINA, SSCH, AAU, NCAA and LEN rules



SWIMMING

Training



A LGE-TIMING developed, especially for training and swimming, a program for the Timy3 with special timing functions for two training lanes.

The following measured values are available:

Single Training

- Reaction time: time after which the swimmer pressure is applied to the starting block
- Pressure time: duration of the jump-off phase
- Block-Off Time: time after which the swimmer leaves the starting block
- Touch 1: first stop
- Turning time: time elapsed from stop to leaving the touchpad
- Touch 2: etc.

During the Relay Training

- Reaction time: time after which the swimmer pressure is applied to the starting block
- Block-Off Time: time after which the swimmer leaves the starting block.
- Touch 1: first stop
- Reaction time: time after which the swimmer pressure is applied to the starting block
- Block-Off Time: time after which the swimmer leaves the starting block.
- Touch 2: etc.

```

ID:      1/1
Freestyle
T:02 Touches
START EXT
15:42:04.380
L1 SB+0.17 0.45 +0.62
L2 SB+0.13 0.56 +0.69
L2 TP 001      27.35
L2 TP Turn Time 0.86
L1 TP 001      28.17
L1 TP Turn Time 0.64
L2 TP 002      1:00.14
L1 TP 002'     1:00.45

ID:      2/1
Freestyle Relay
T:04 Touches
START EXT
15:42:04.380
L1 SB+0.25 0.40 +0.65
L2 SB+0.28 0.44 +0.72
L2 TP 001      27.35
L2 SB-0.25 0.30 +0.05
L1 TP 001      28.17
L1 SB-0.15 0.25 +0.10
    
```

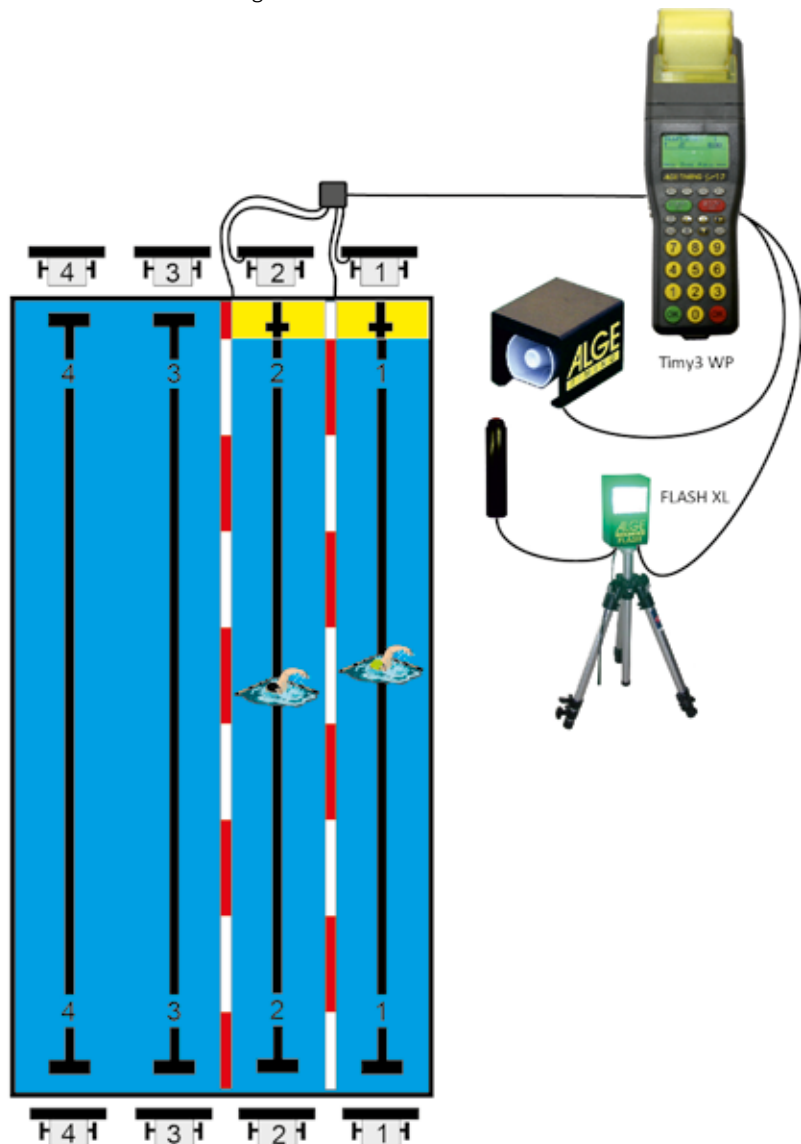



SWIMMING

Display Boards

ALGE-TIMING has the right display options for every application, which can be adapted to individual requirements, ranging from classic seven-segment display boards to video walls.

Numerical LED Display Systems

The seven-segment LED display boards are ideal for indoor and outdoor use.

LED Full Color Display Systems and Full Matrix Systems

ALGE-TIMING can offer LED large-area display systems and video walls designed for use in sports facilities (see video wall - LED-Matrix).

Seven Segment LED Display Board

The D-SWxxx series display boards are specially designed for indoor and outdoor applications. The timing is controlled by the TimeManager TM-SWIM, Timy3 or the multi-port console D-CKN. All LED display boards from ALGE-TIMING are equipped with extra bright LEDs with a lifetime of over 100,000 hours. The display boards are available with a height of 57 mm up to 600 mm.

Digits for indoor display systems: 57, 100, 150, and 250 mm

Digits for outdoor display systems: 80, 150, 250, 450 and 600 mm

D-SWxx-8- (IO)

One-line display to indicate rank, lane and time. The results of all swimmers can be displayed alternately. The optional water polo console can be used to display game time and goals (0 to 9).



seven-segment LED Scoreboard



example: D-SW25-8-0

D-xxxSWxx-7 (8) - (IO)

It is possible to display the time for each lane. Thus, there are multi-line display boards with different configurations that are individually selectable. With the optionally available water polo console, the game time, goals and penalties are displayed on the scoreboard.

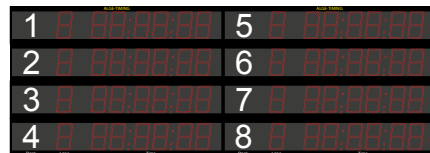

example: D-2x4xSW25-8-0

D-SWxx-5- (IO)

This additional display provides the spectators with a complete overview of the competition. It displays both the event name and the heat number. This option can be directly integrated into any display.



SWIMMING

Display Boards



D-RTNMxx-x- (IO) Info Display Systems

The D-RTNM full matrix display systems offer incredible display possibilities. In addition to the event name, heat number and the name of the swimmers, this board can also be used for advertising purposes: Graphic animations and scrolling texts can be called up at any time by a mouse click.

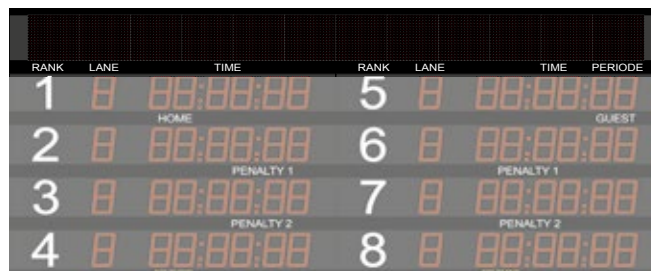

Personal Fouls for Water Polo

D-WPF10- (IO) (for D-4xSW10-x)

- LED diameter: 10 mm
- LED cluster diameter: 10 mm
- number of LEDs per point: 1
- dimensions: 350 x 900 x 70 mm per side
- weight: 6.5 kg per side

D-WPF15- (IO) (for D-4xSW15-x)

- LED diameter: 5 mm
- LED cluster diameter: 20 mm
- number of LEDs per point: 5
- dimensions: 400 x 1,100 x 70 mm per side
- weight: 10 kg each side

D-WPF25- (IO) (for D-4xSW25-x)

- LED diameter: 5 mm
- LED cluster diameter: 35 mm
- number of LEDs per point: 10
- dimensions: 500 x 1,400 x 70 mm per side
- weight: 15 kg per side

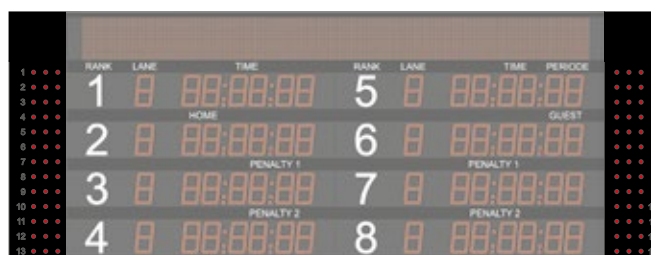

The above display boards are available as indoor and outdoor versions.



SWIMMING

OPTIc3 Video Backup

The photo finish system OPTIc3 from ALGE-TIMING can capture all movements in the start-finish area in 2-D mode with 100 images per second. These recording is an independent backup for the timing, or it may serve as evidence in case of a

protest. This can be very helpful, especially with relay. The images are stored on the hard disk of a PC and can be evaluated quickly and clearly with the IDCam software. A camera can record up to 4 tracks.



- Picture frequency: 100 frames per second
- Picture resolution: 360 x 2,016 or 1,024 x 768 pixels
- Admission: endless, depending on the hard disk capacity of the PC
- Synchronization: The system can be synchronized with the TimeManager.

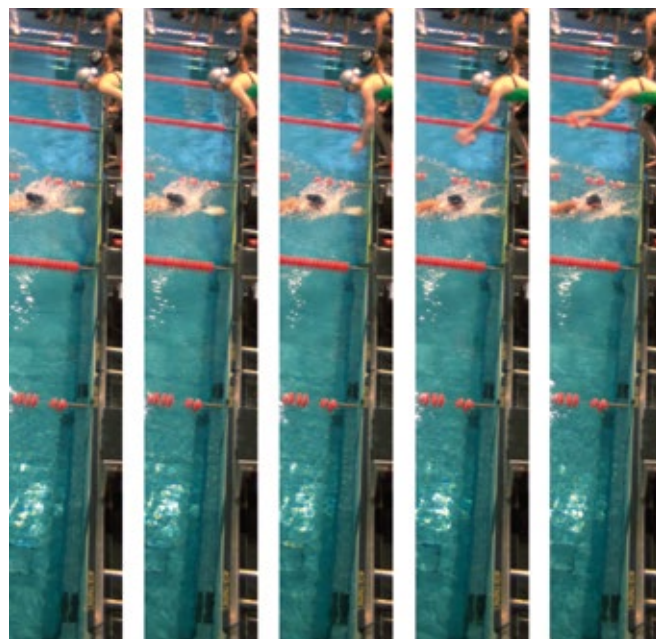

SWIMMING

Open Water



For open water competitions, a combination of several small touchpad and an IDCam is suitable, which creates several high-resolution images including the time of the day, on which the start numbers of the swimmers are easily recognizable.

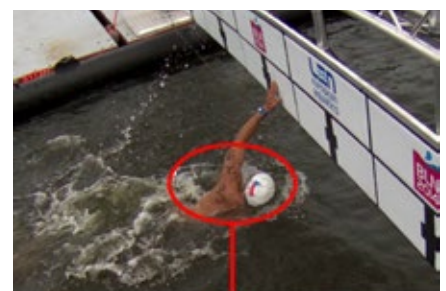
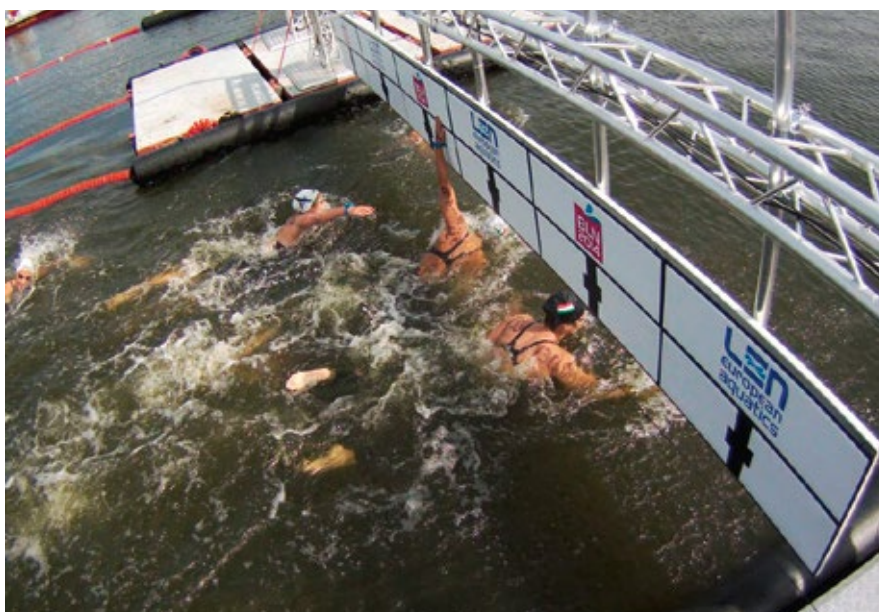
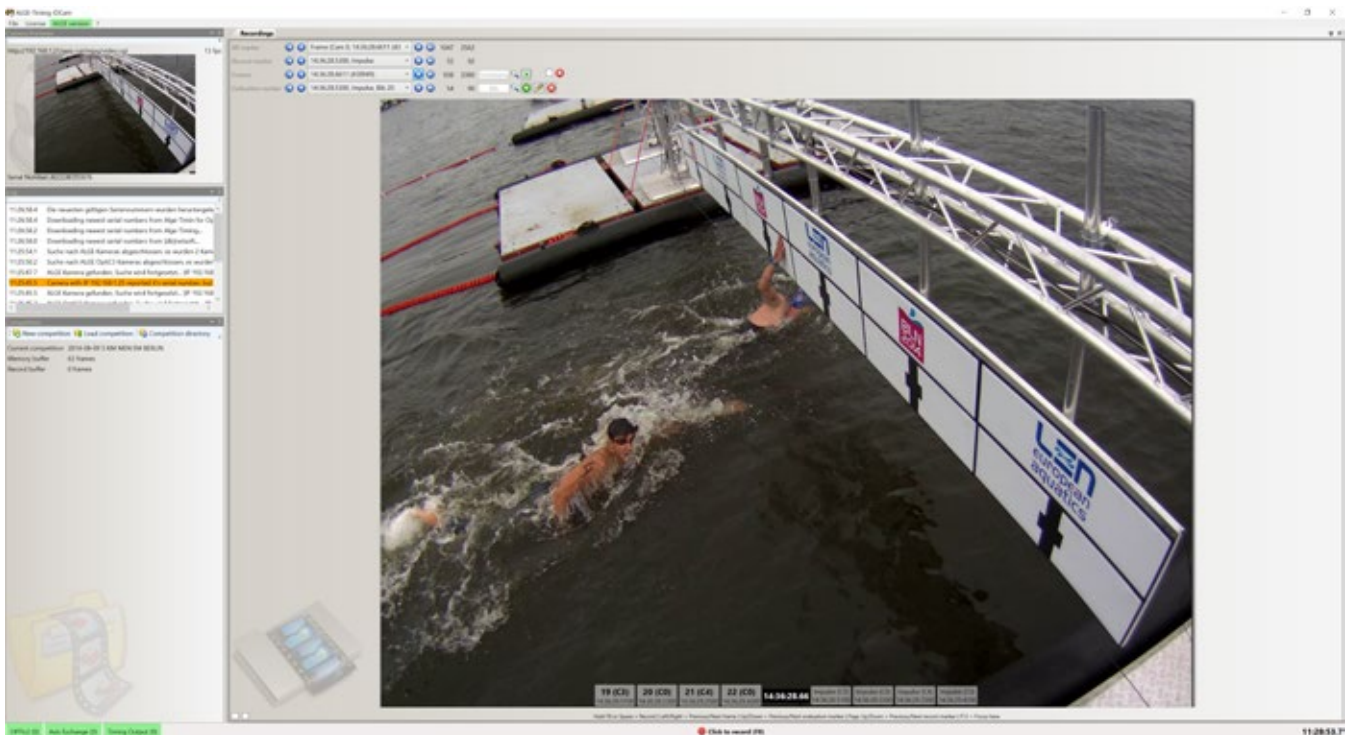



ARTISTIC SWIMMING

In artistic swimming, the use of ALGE-TIMING's unique Wireless Timing Network ensures secure data transmission and allows easy setup of the system.

The evaluation software complies with the requirements of the FINA and can control video walls and numerical displays of ALGE-TIMING.

| Artistic swimming TEAM TECHNICAL ROUTINE | |
|---|---|
|  RUSSIA | RUS 1 |
| Vlada CHIGIREVA | Execution 28.9000 Impression 28.5000 Elements 35.5268 92.9268 |
| Mikhaela KALANCHA | |
| Svetlana KOLESNICHENKO | |
| Lilia NIZAMOVA | |
| Elena PROKOFYEVA | |
| Alla SHISHKINA | |
| Maria SHUROCHKINA | |
| Gelena TOPILINA | |

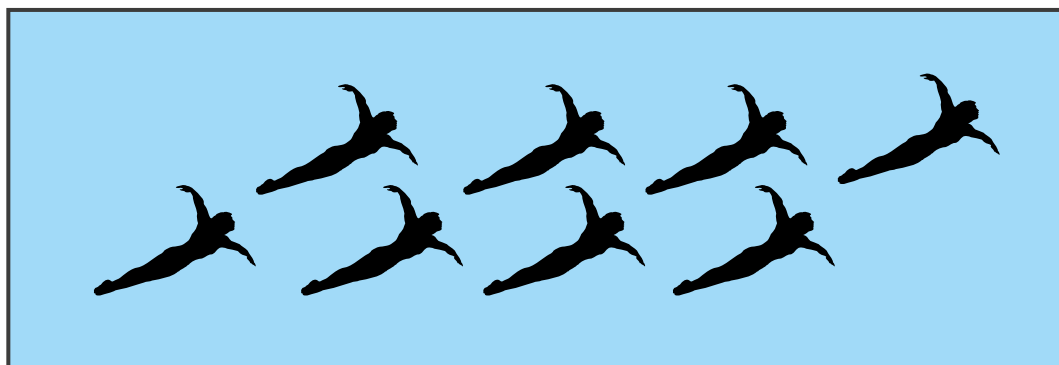

DIVING



The evaluation system is based on the unique Wireless Timing Network from ALGE-TIMING. This ensures a secure data transmission and a simple setup of the system.

The evaluation software complies with the requirements of the FINA and can control video walls and numerical displays of ALGE-TIMING.

| BLN 2014 | | Synchronized 3m - MEN FINAL | | |
|----------|--|---|-----|-----------------|
| 1 | | Ilya ZAKHAROV Evgenii KUZNETSOV | RUS | 464.64 |
| 2 | | Patrick HAUSDING Stephan FECK | GER | 438.15 26.49 |
| 3 | | Oleksandr GORSHKOVOZOV Illya KV ASHA | UKR | 433.98 30.66 |
| 4 | | Michele BENEDETTI Giovanni T OCCI | ITA | 400.59 64.05 |
| 5 | | Christopher MEARS Jack LAUGHER | GBR | 391.98 72.66 |

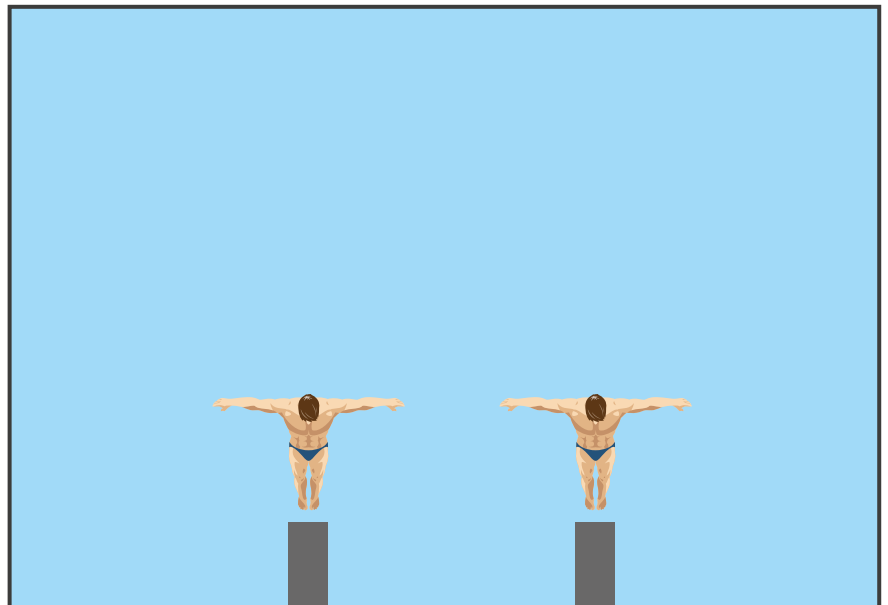



WATER POLO

Scoreboards

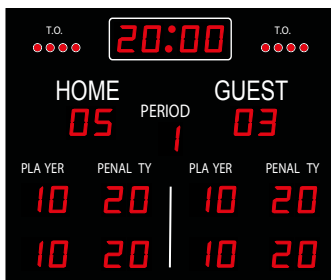

model D-S10BP2W



model D-S10-5W

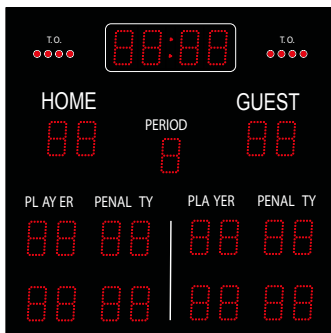

model D-S15BP2W



model D-S15-5W

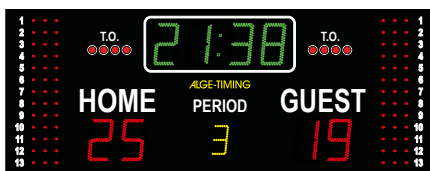

model D-M1SW

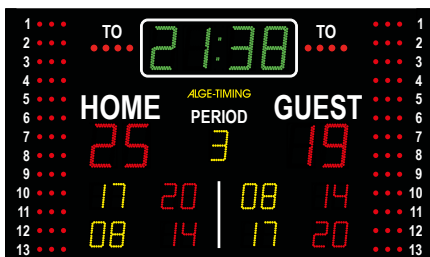

model D-M5SW

Model D-S10BP2W

- digit height: 100 mm
- dimensions: 1,200 x 1,000 x 70 mm
- weight: 25kg

Model D-S10-5W

- digit height: 100 mm
- dimensions: 2,000 x 1,200 x 70 mm
- weight: 45kg

Model D-S15BP2W

- digit height: 150 mm
- dimensions: 1,400 x 1,400 x 70 mm
- weight: 40 kg

Model D-S15-5W

- digit height: 150 mm
- dimensions: 2,000 x 1,400 x 70 mm
- weight: 55 kg

The following is displayed on the scoreboard:

- running time: 99:59 minutes up/down (green digits except on the S models - red digits). Last game minutes show the current tenth of a second.
- daytime can be displayed in the game time field
- goals: 0 to 99 on each side (red digits)
- period: 0 to 9 (yellow digits, except for the S models - red digits)
- time out: 4 red LED points for each team
- penalties: two penalty times for each team: 0 - 59 seconds (red digits)
- player ID: 0 to 99 (yellow digits, except for the S models - red digits)
- personal fouls: 39 red LED points for each team (models S10WL, S15WL and M6W)

Technical Data

- power supply: 110 - 220 V AC/50 Hz, shot clocks with 24 V DC directly from the main scoreboard
- horn
- D-CKN console with LCD display

Optional

Wireless data transmission only between console and main display possible, shot clocks need 12 V from the main display, for safety reasons.

All models, except D-S are also available in outdoor versions.

WATER POLO

Shot Clock



shot clock for water polo (beach ball)

D-SC15W-PH (Indoor) or D-SC15W-PH-O (Outdoor)

- attack time (2 digits): 15 cm
- dimensions: 34 x 25 x 7 cm
- weight: 1.5 kg per side

D-SC25W-PH (Indoor) or D-SC25W-PH-O (Outdoor)

- attack time (2 digits): 25 cm
- dimensions: 45 x 35 x 7 cm
- weight: 3 kg per side

D-SC25GT15W-PH (Indoor) or D-SC25GT15W-PH-O (Outdoor)

- game time (3 digits): 15 cm
- attack time (2 digits): 25 cm
- dimensions: 55 x 55 x 7 cm
- weight: 6 kg per side

D-SC45GT25W-PH (Indoor) or D-SC45GT25W-PH-O (Outdoor)

- game time (3 digits): 25 cm
- attack time (2 digits): 45 cm
- dimensions: 85 x 90 x 7 cm
- weight: 15 kg, per side

Technical Data

- The set consists of 2 shot clock displays each with horn.
- 15, 25 or 45 cm digit height, upon request, up to 100 cm possible
- models for indoor and outdoor, power supply with 24 V DC from main display
- works only with an ALGE-TIMING water polo scoreboard, with D-CKN console
- Cables must be ordered separately, 200-XX are utilized.
- Radio connection is not possible.





ROWING/CANOEING

Simple Timing System

Rowing and canoe events require different time measuring systems, such as a simple system with manual timing for each track and radio transmission.

As the name suggests, this timing system is simple and allows for mobile use. The start takes place by means of a manual push button, which emits a horn signal via the Startbeep STB1. One or more start beeps can be distributed along the lanes in the start area.

The Timy3 WP in the start area is required for reliable storage of the start time, i.e. as a backup.

The start impulse is transmitted via radio TED to the finish. A manual push button is available for each lane. On the timing device, up to eight lanes are recorded and printed (eight different timing channels).

It is also possible to connect to the Timy3 in the finish a display board showing the running time or the winner's time.

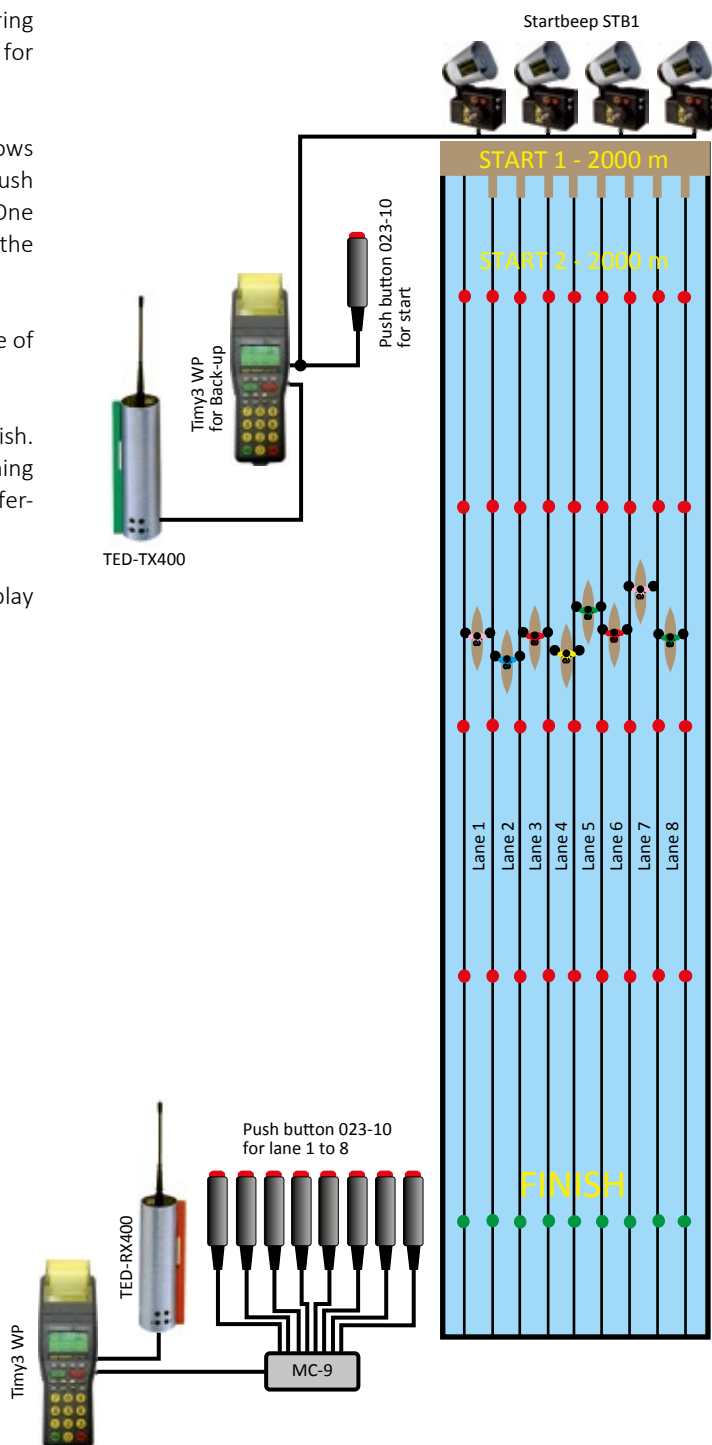

ROWING/CANOEING

Professional Timing System



The professional timing system with the TimeManager TM allows to output all channels for each lane with identification (interim time and finishing time). This means for a regatta course with nine lanes there is one start channel, three times nine interim times and nine finishing times, altogether 37 timing channels.

Via the TimeManager at the start the starter can announce starting commands as well as the starting signal by speakers to the rowers.

For each interim time and the finish there are manual push buttons with which each lane can be triggered separately.

The finish is recorded and analyzed by the photo finish system OPTic3.

The evaluation PC receives all data from the timing device and analyzes it. The complete race rankings are done by the evaluation PC as well as printing of the lists.

For communication between start, interim time and timing headsets are at disposal.

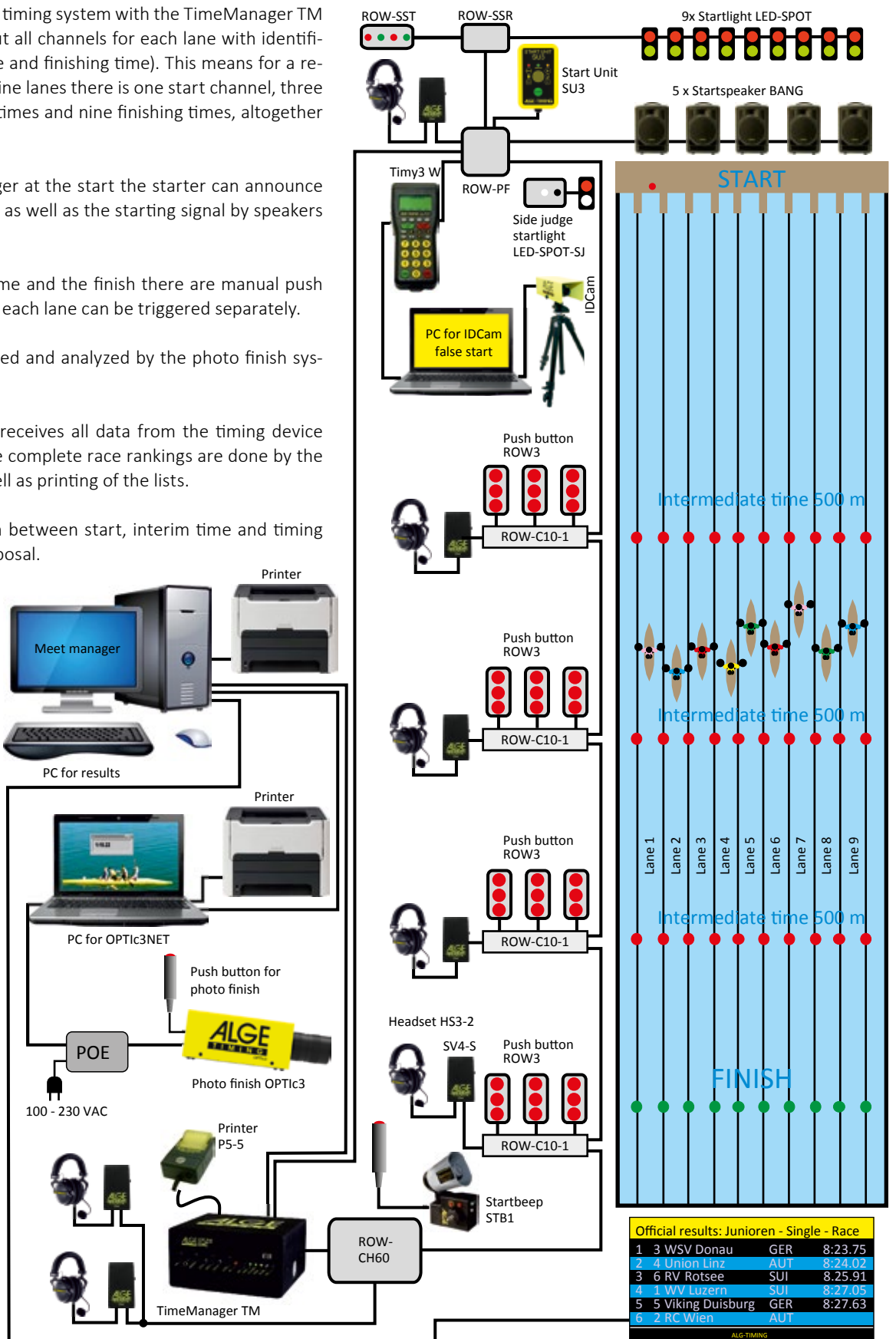

| Official results: Junioren - Single - Race | | | |
|--|---|-----------------|-------------|
| 1 | 3 | WSV Donau | GER 8:23.75 |
| 2 | 4 | Union Linz | AUT 8:24.02 |
| 3 | 6 | RV Rotsee | SUI 8:25.91 |
| 4 | 1 | WV Luzern | SUI 8:27.05 |
| 5 | 5 | Viking Duisburg | GER 8:27.63 |
| 6 | 2 | RC Wien | AUT |

All computers in the illustrated system are connected in a network.

Videowall



MOTOR SPORTS





Car Slalom / Mountain Racing

An example of a timing system used in motor sports is the system for car slalom or mountain racing (shown at the right).

The regular start intervals can be controlled via a Startclock ASC3. The timing is triggered by a photocell at the start. The starter and timing operator can communicate via headsets.

When triggered, the finish photocell stops the time of the TdC8001 or Timy3.

A display board can be controlled by the timing device.

If there is a large distance between the start and the finish, the Teledata TED400 can be used for impulse transmission.



The versatility of the motor sport requires a large selection of timing systems, which meet the challenges of different races. This is why ALGE-TIMING has developed individual timing systems and the appropriate accessories especially for motor sports.

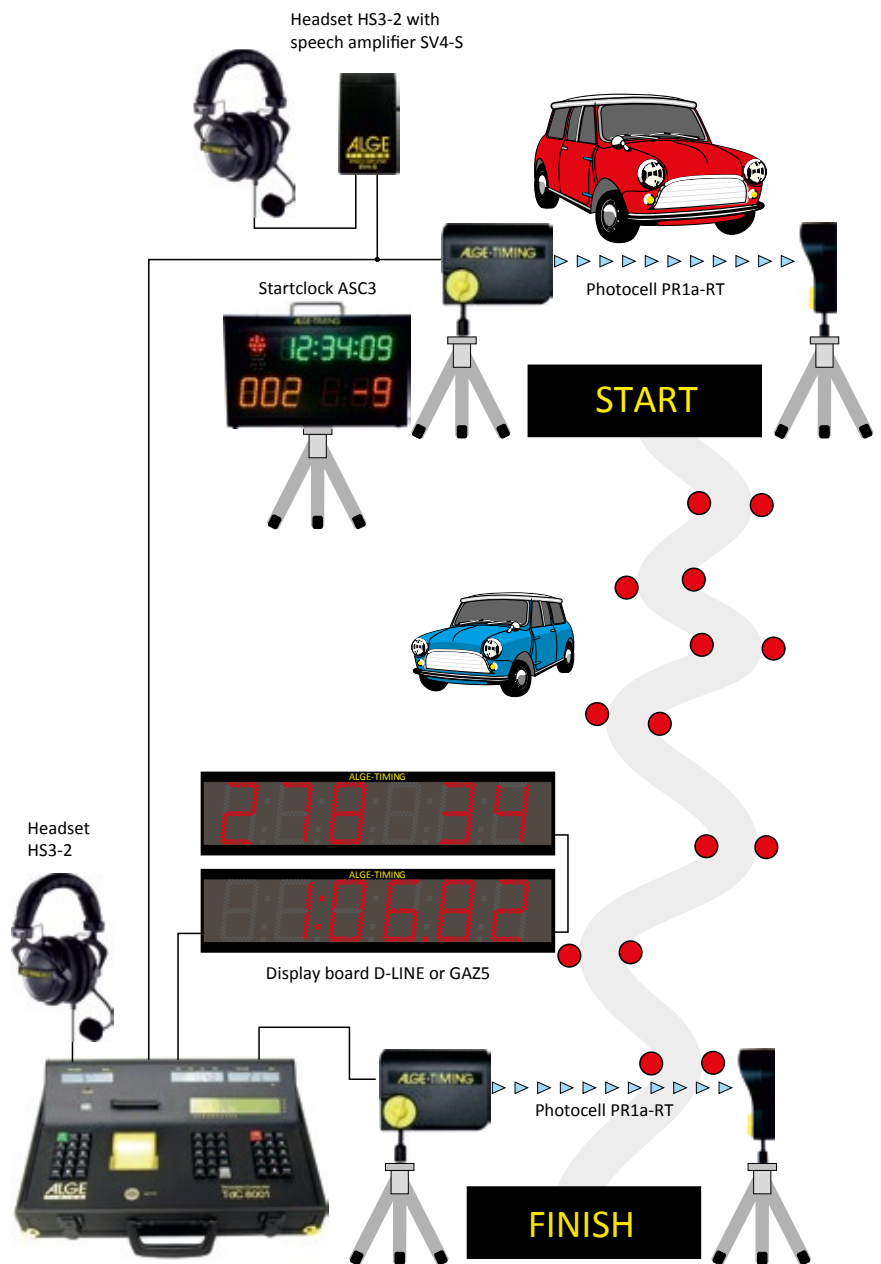



MOTOR SPORTS

Dragsters

For dragster races there are different ways to measure the times and record the results. For the sake of illustration, a simple system is presented, which can be customized according to the specific wishes of clients and the intended use. This means that, for example, the exact speed in the finish region can also be measured.

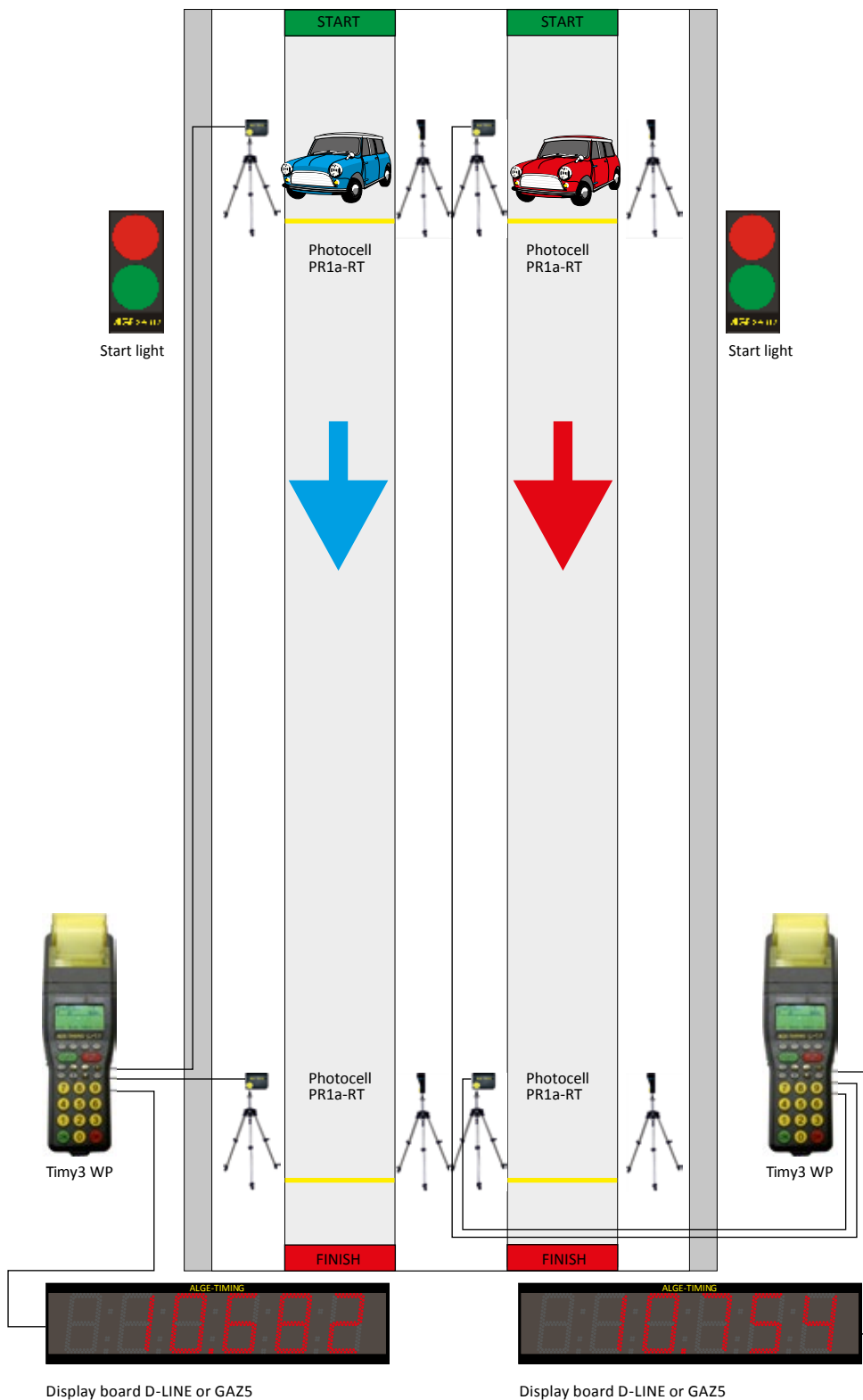



The timing for a rally consists of at least one timing system with two Timy3 WP and a manual push button. Of course, the system can be expanded with additional devices, which make a more precise timing possible.

In the figures, a timing device Timy3 WP and a photocell are used for a simple timing system for start and finish. The time of day is always measured. The timing operator enters the ID-number of the vehicle into the Timy3. The run time is calculated from the difference of start and finish time.

Simple rally timing system with cable

A Timy3 WP is connected to the photocell at the start, the other to the photocell in the finish. Both Timy3 are synchronized before the start of the race.

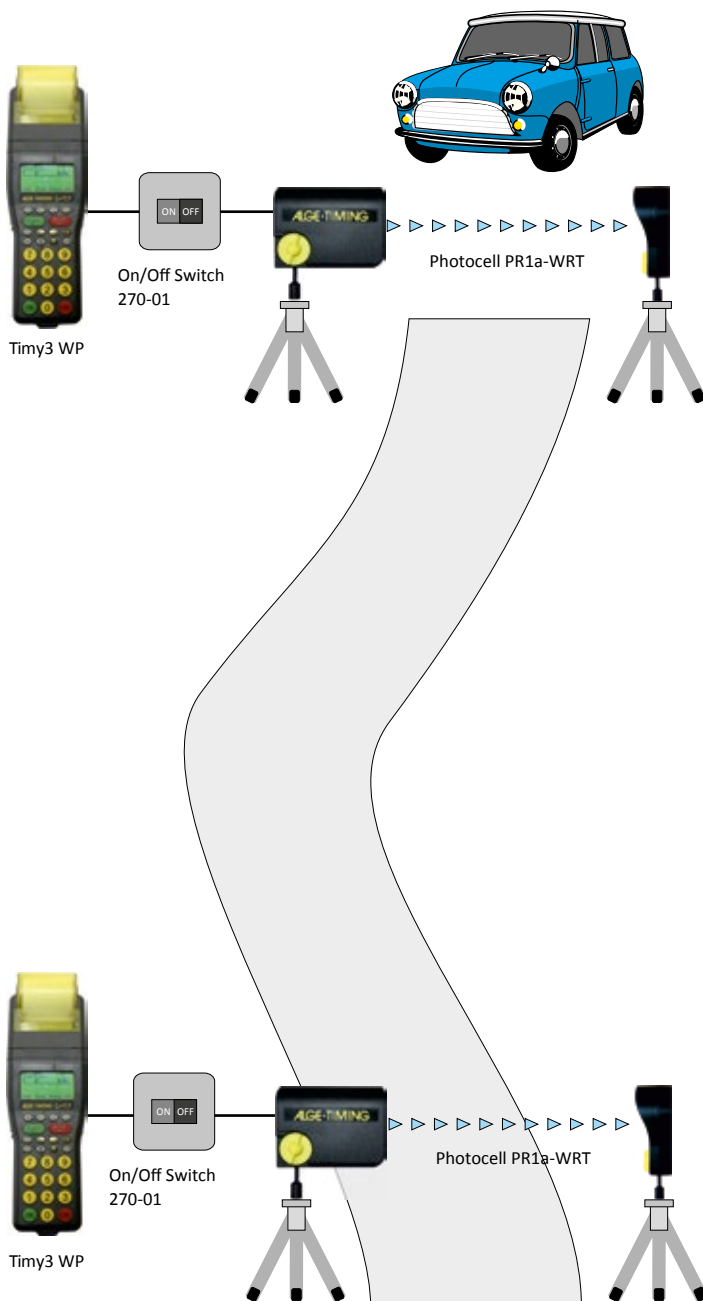

Simple rally timing system with radio

The Timy3 WP and photocell PR1aW have an integrated Wireless Timing Network WTN. Both Timy3 are synchronized before the start of the race.

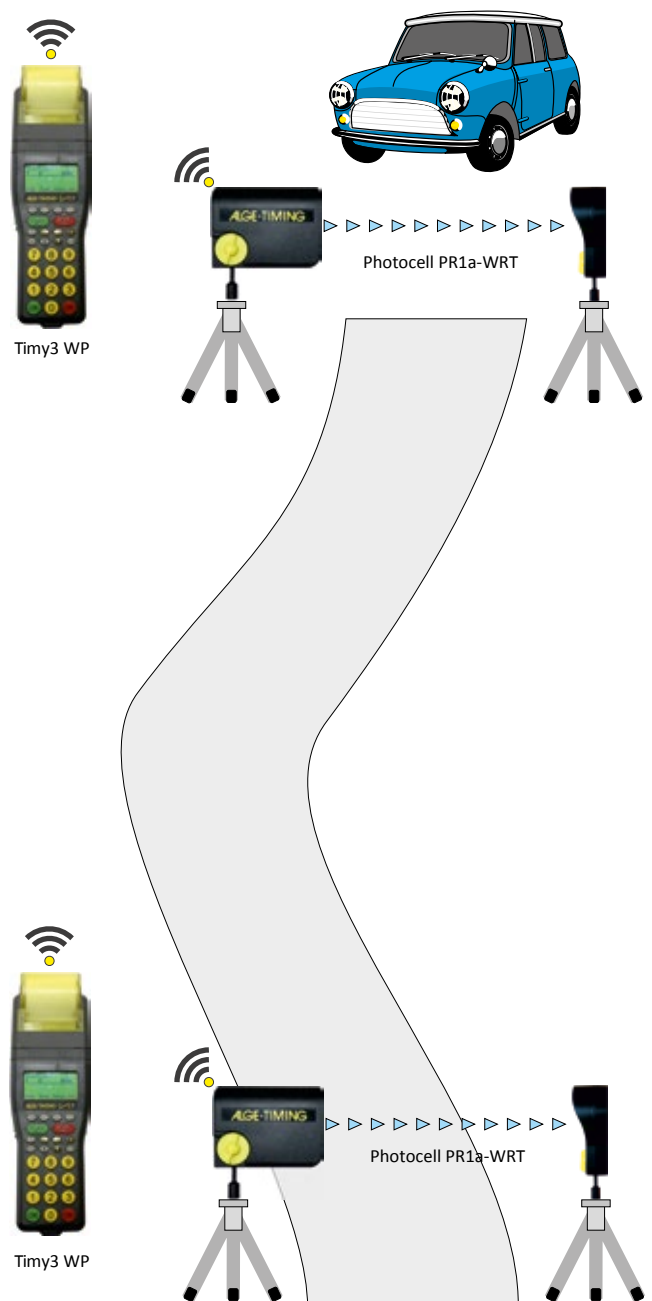



MOTOR SPORTS

Rally

A Timy3 and photocell is located at the start and finish.

The ID-number and time of each car is stored in the timing device at start and finish. After the stage is finished the data from each timing device are transferred to a PC, which calculates the run times.

For each stage that is executed at the same time you need additional timing system. Sometimes it is also necessary to have additional timing systems to prepare the following stages.

This solution with Timy3 and photocell at start and finish is supported by a Startclock ASC3 to keep regular start intervals.

The ID-number and time of each car is stored in the timing device at start and finish. After the stage is finished the data from each timing device are transferred to a PC, which calculates the run times.

For each stage that is executed at the same time you need additional timing system. Sometimes it is also necessary to have additional timing systems to prepare the following stages.



MOTOR SPORTS

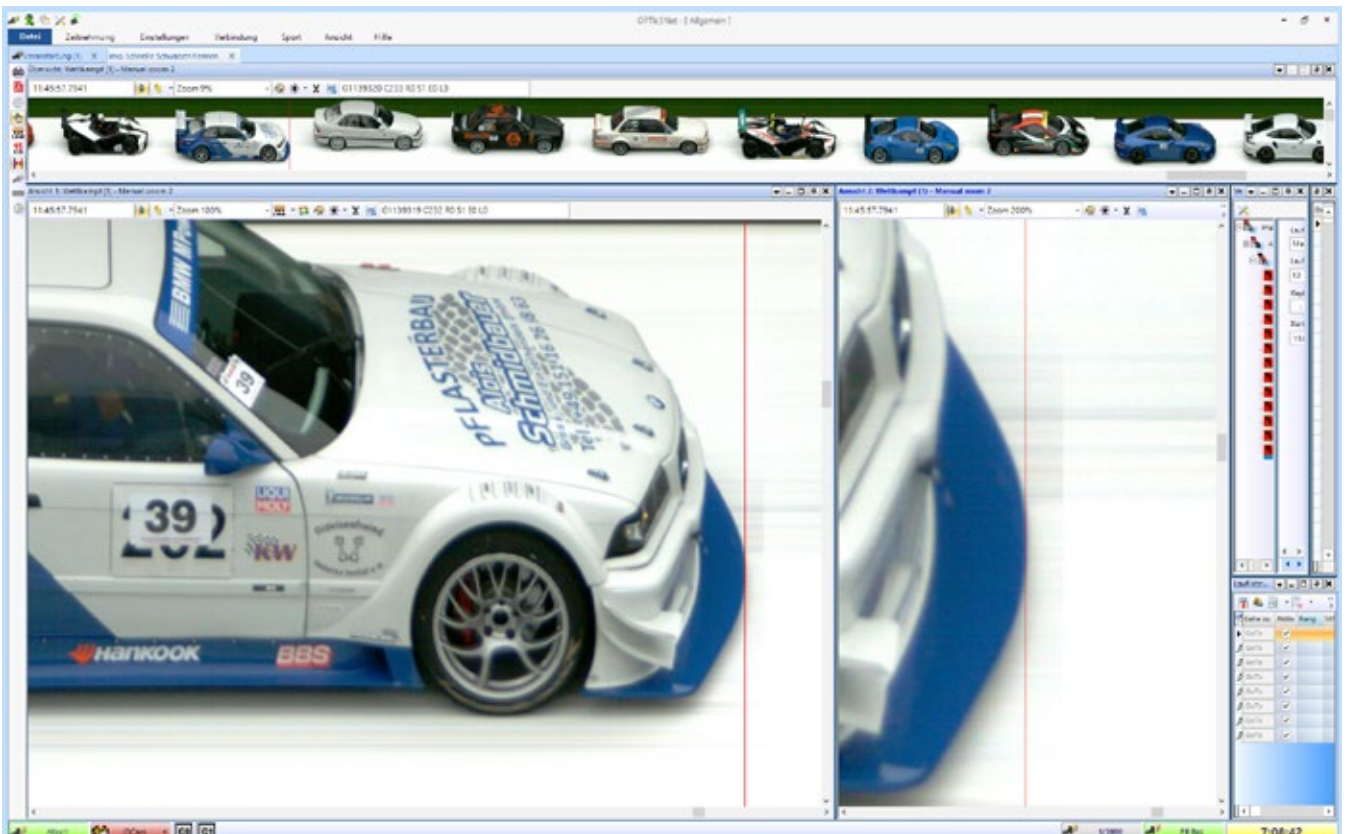



SPORT CLIMBING

Speed Climbing

ALGE-TIMING offers a timing system especially developed for speed climbing. The acoustic start signal comes from the Startbeep STB1. Both tracks have a contact mat on the floor in the starting area. This allows to check false starts. If a climber leaves the contact mat before the start signal is given, the display board shows FS (false start) and the false start light will light up red. Of course, the false start is protocolled on the printer of the timing device Timy3 WP.

The finish is triggered via contact mats at the top of the wall. The timing device measures the run time of each competitor and displays it on the display board D-LINE.

Alternative ALGE-TIMING offers as well automatic training systems that can be fix installed on the climbing wall.

The ALGE-TIMING timing system is recommended by FISC (International Federation for Sport Climbing).

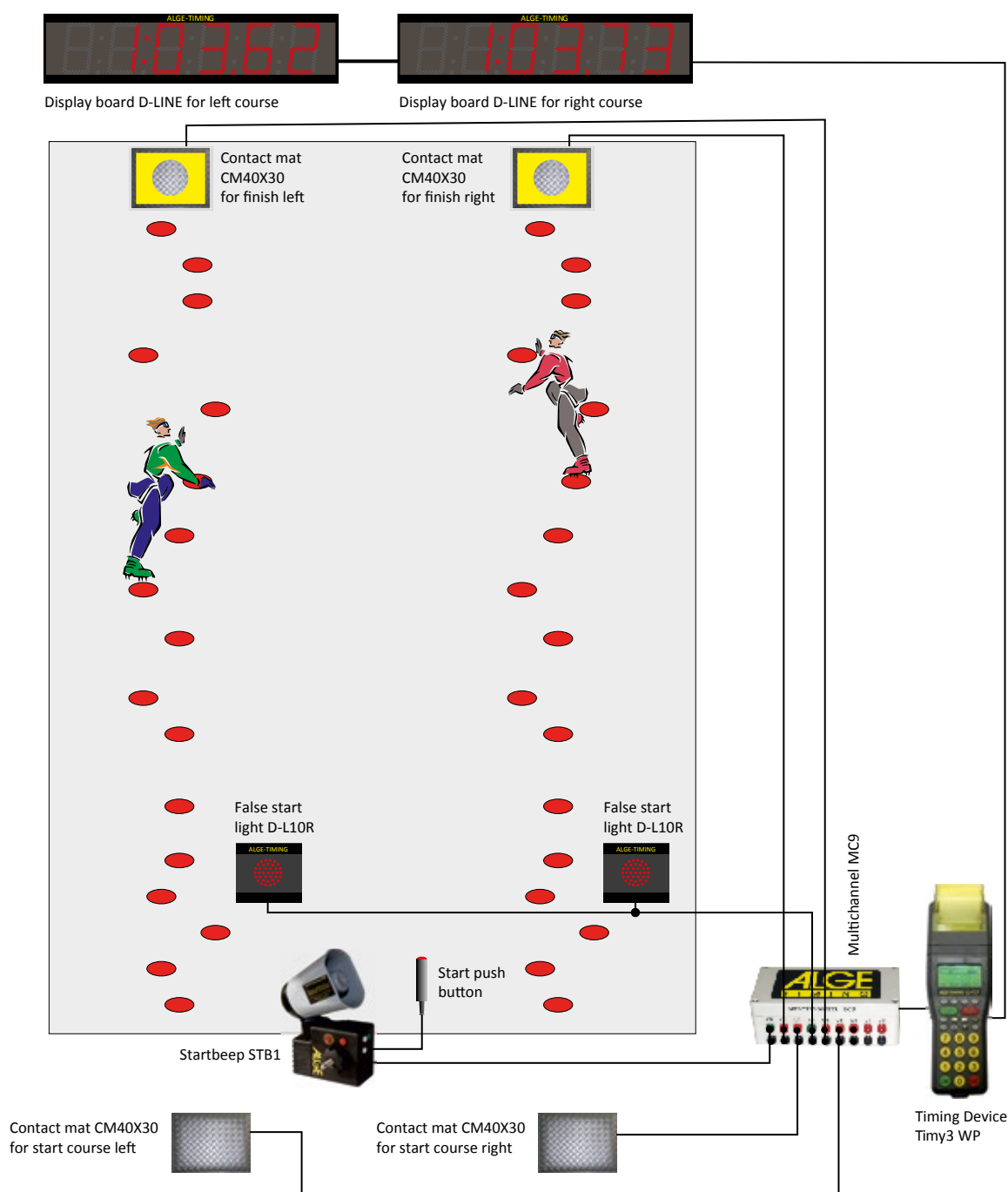



Devices that are required for timing during speed climbing

Timy3 WP

The Timy3 WP is the control center from which all devices are controlled and timing impulses are processed. When the start is triggered, the starting sound is emitted via the Startbeep STB1 with a countdown of 3 seconds according to the regulations. Also, the false start is checked and the display board is driven by the Timy3.



Multichannel MC9

The MC9 is a docking station for the Timy3. The contact mats, the start beep and the false start light are connected to the Multichannel MC9.



Startbeep STB1

Device with integrated horn, which omits the start sound.



Contact Mat CM40x30 for Start

Checks whether the climber does not leave the start before the start tone.



Contact Mat CM40x30 for Finish

When the climber strikes the contact mat, the timing is stopped.

Display Boards D-LINE

The display shows the running time and run time for a competitor. In case of a false start it shows "FS".



False Start Light D-L10R

The false start light shows the climber on the wall that a false start occurred. It is usually integrated into the climbing wall.





ALPINE SKIING



ALPINE SKIING

General Information



A wide range of timing devices and accessories are available from ALGE-TIMING for alpine ski races. Important is mainly the reliability and rugged design for difficult conditions like freezing temperatures and snow. Most of the devices of ALGE-TIMING are homologated by the FIS (International Ski Federation).

ALGE-TIMING has a long history in timing for alpine skiing. The market share of more than 40% of ALGE-TIMING equipment used in FIS races shows clearly the leading role.

Although timing devices were produced for many years, most of the older models are still compatible with the current ones.

| | | | |
|---|--|--|------------------------|
|  | | CONTROLE OFFICIEL SUISSE DES CHRONOMETRES | |
| BUREAUX OFFICIELS DE CONTROLE (BO) de Bienne, Le Locle, Saint-Imier | | Edition : 1 | Edited by : PSO |
| Homologation Report FEI | | Date : 20.10.2014 | Page : 1 of 4 |

| | | | |
|---|---|--|--|
| Homologation Report of Timing Device ALGE-TIMING TIMY3 WP Photocell ALGE-TIMING PR1aW and integrated Wireless Transmission | | | |
| based on FEI Procedure for approval of timing devices (30.04.2013) | | | |
| Report Number | FEI-TPW-ALG_2014001 | | |
| Requested by | ALGE-TIMING GmbH Mr. Albert Vetter Rotkreuzstrasse 39 A-6890 Lustenau | | |
| Description of equipment | Multi sports timing device, internal printer with battery Photocell (Wireless Transmission available) | | |
| Type | Timer: TIMY3 WP | Photocell: PR1aW | |
| Manufacturer | ALGE-TIMING GmbH | | |
| Serial Number | Timer: 140123009 | Photocell: 131016071 | |
| Production Year | Timer: 2014 | Photocell: 2013 | |
| Date(s) of measures | 25.08.2014 – 03.09.2014 | | |
| Date of report | 20.10.2014 | | |
| Location(s) of measures | Bureau Officiel de Saint-Imier | | |
| Rules | FEI Procedure for approval of timing devices (30.04.2013) | | |
| Results | Passed | | |
| Signatures | Tests and report by Pascal Soltermann  | Controlled by Andreas Wyss  | |
| Comments | The reference triggering is within +/- 1µs GPS time-scale absolute time, uncertainty and propagation delays are included. DUT Time-of-Day is synchronized electronically through discrete c0 input with 60s reference pulse. Low resolution inputs (c6, c7 and c8) were not tested. | | |
| Content: | Abbreviations: | | |
| Report: 4 pages | P = Pass | N/C = Not Conducted | |
| Appendices: none | F = Fail | DUT = Device Under Test | |
| | N/A = Not Applicable | GPS = Global Positioning System | |

| | |
|--|---|
|  | |
| Company: ALGE-TIMING Timer Name: Timy3 WP Codex Timing: ALG.090.14 Date: October 2014 |  FIS Timing Working Group |

Radio Timing

With the Teledata TED400 ALGE-TIMING offers a first-class radio system, which can be used in FIS races if it fulfils certain criteria:

The main criterion is to have at least two independent time measuring devices at the startgate in order to record the start time.



ALPINE SKIING

Simple Timing Solutions

For timing at alpine skiing races, a simple timing system can be used as base system, consisting of a timing device, startgate and photocell. We recommend as well the headsets for a speech connection between start operator and timing operator, a start device as the Startclock ASC3 or Startbeep STB1, and a display board.

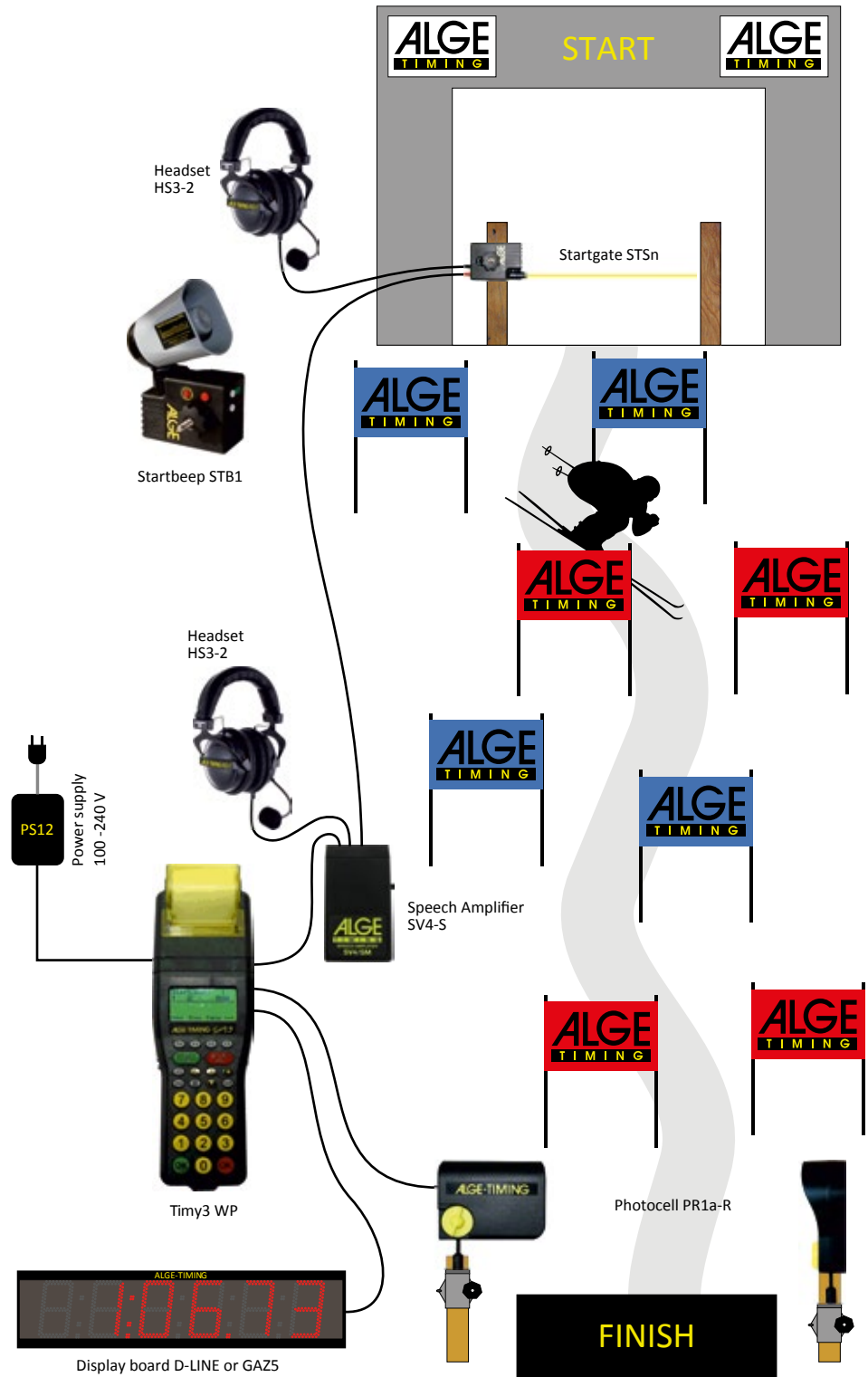

ALPINE SKIING

FIS Timing System



The timing system in the sketch below is set up as needed for FIS races or Continental Cup races (e.g. Europa Cup). An intermediate time is not mandatory. Using an intermediate time

we recommend to use a separate timing device, since a competitor could reach at the same time at the intermediate as another competitor goes through the finish.

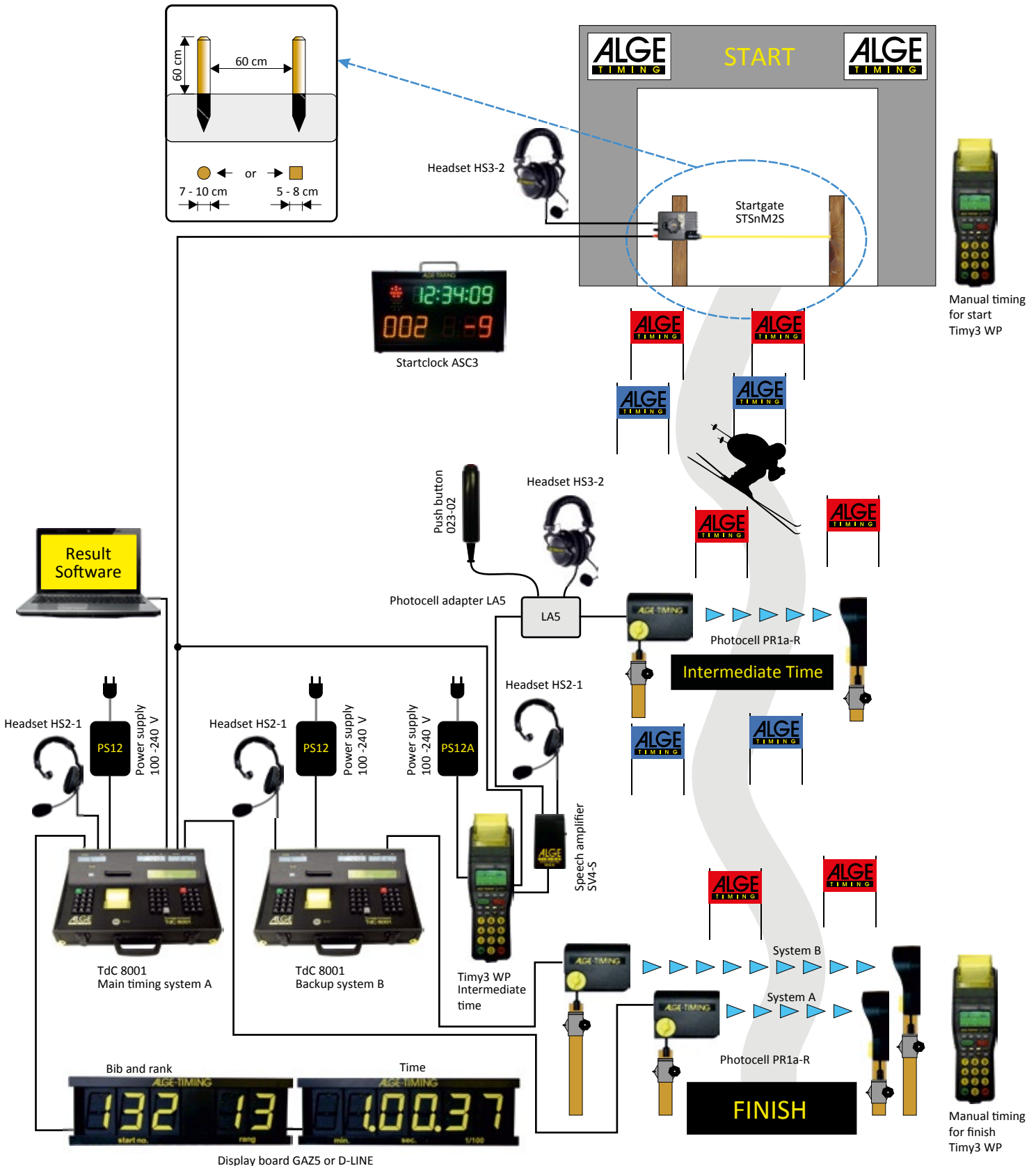



ALPINE SKIING

Training System

A large number of professional users, such as ski national teams, ski manufacturers, or waxing companies, use the ALGE-TIMNG training system because they appreciate the high reliability and performance of the radio system TED400. Even on alpine terrain long distances can be bridged.

Almost all components of the ALGE-TIMING training system are also usable for timing at races. The timing device Timy3 as well as the photocells are FIS homologated. Even the radio TED400 is allowed to use at FIS-races when the rules are as specified by FIS

are followed (timing devices at the start for main and backup).

The below shown training system consists of start, intermediate time and finish. ALGE-TIMING can support up to 8 intermediate times.

ALGE-TIMING recommends to use for training the timing device at the start. This allows the racer to input his ID-number and to check his time(s) or run times from other racers.

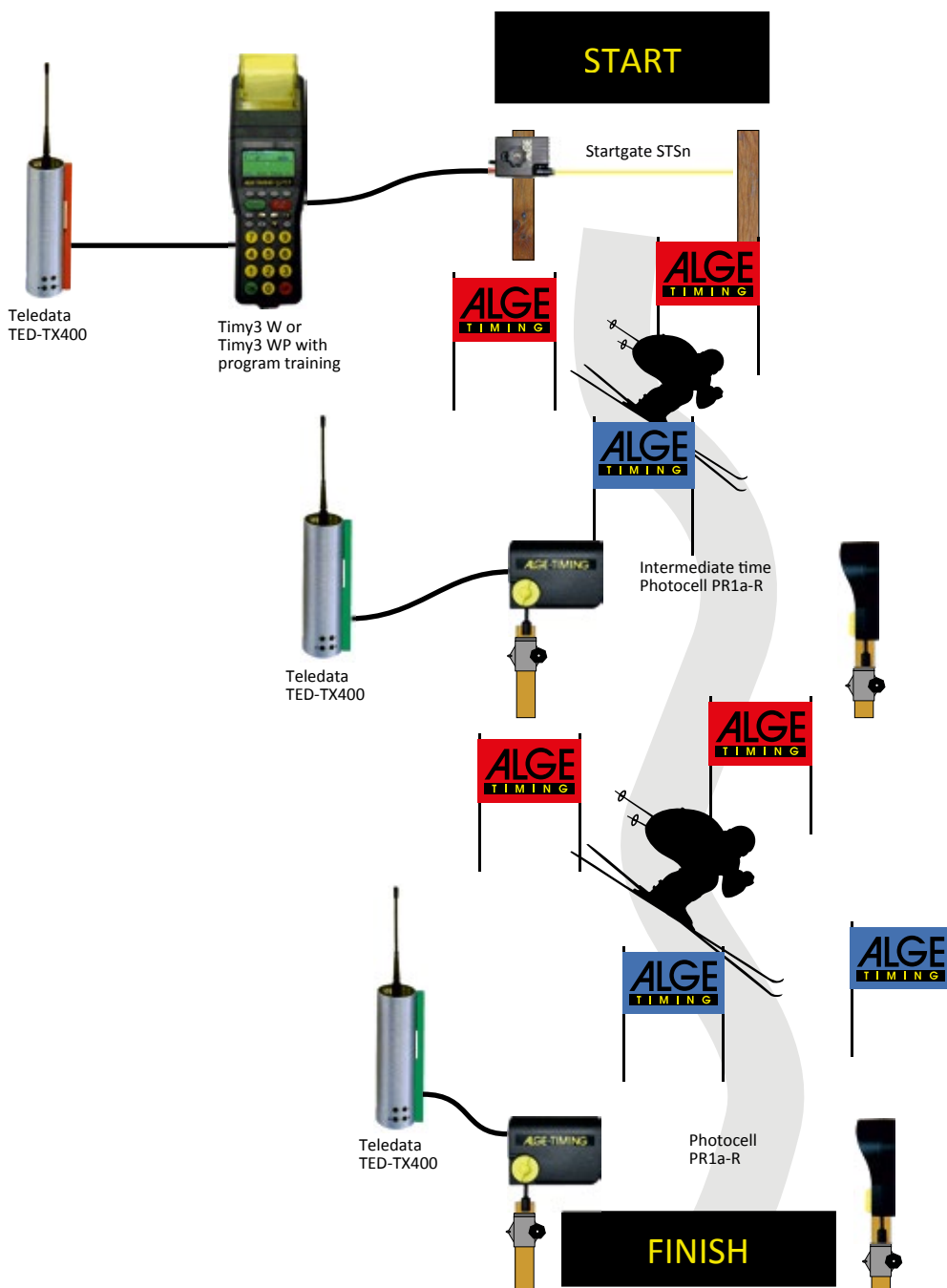



Self Service Timing for Permanent Race Courses

Components of the System

Selftimer Start Light SF3L

The start light is mounted at the start and regulates the starting sequence. The green light indicates that you can start, and the red light will light up after the start, until the previous competitor has reached the finish or a maximum run time has elapsed.



Selftimer Coin Collector SF3P

The SF3P is installed at the start and has an integrated coin collector that accepts local token or coins and collects them in a closed, impact-resistant case. A light (red and green) controls the coin insertion and a second light (red and green) the start sequence.



Startgate STSnA1

The startgate is used to trigger the start. The STSnA1 has a startwand that automatically closes and is equipped with a mounting chain.



Photocell PR1a

The photocell is used for the timing device in the finish or for the speed measurement. It consists of a transmitter/receiver unit and a reflector, both of which are easily and precisely aligned with a ball head. The photocell is screwed onto a mounting bracket and attached to a wooden post with a chain. A cover protects the lens of the photocell from rain and snow.



Display Board D-SF150-O-6-E0 or D-SF250-O-6-E0

Six extra bright, red LED digits with a figure height of 150 mm (D-SF150) or 250 mm (D-SF250) ensure the best visibility even in direct sunlight. The integrated electronic controls the entire SF3 system, including minimum and maximum run time and start light indicator. The display board shows alternative run time or speed. The display board can also be used with other ALGE-TIMING timing devices.



Display Board D-LINE150-O-6-E0 or D-LINE250-O-6-E0

The D-LINE display board has no selftimer controller integrated in comparison to the D-SF. This display board can also be used at the start, so that the racers waiting at the start can see the times.

Necessary Cables and Connections

Selftimer System with Start Light SF3L

Cable between start and display board: 1 pair (2 lines)

Power supply: 100 - 240 VAC or 12 VDC for the display board

Selftimer System with Start Light SF3P

Cable between start and display board: 2 pairs (4 lines)

Power supply: 100 - 240 VAC or 12 VDC for the display board



Start Light SF3L



Start Light SF3P



ALPINE SKIING

Selftimer SF3

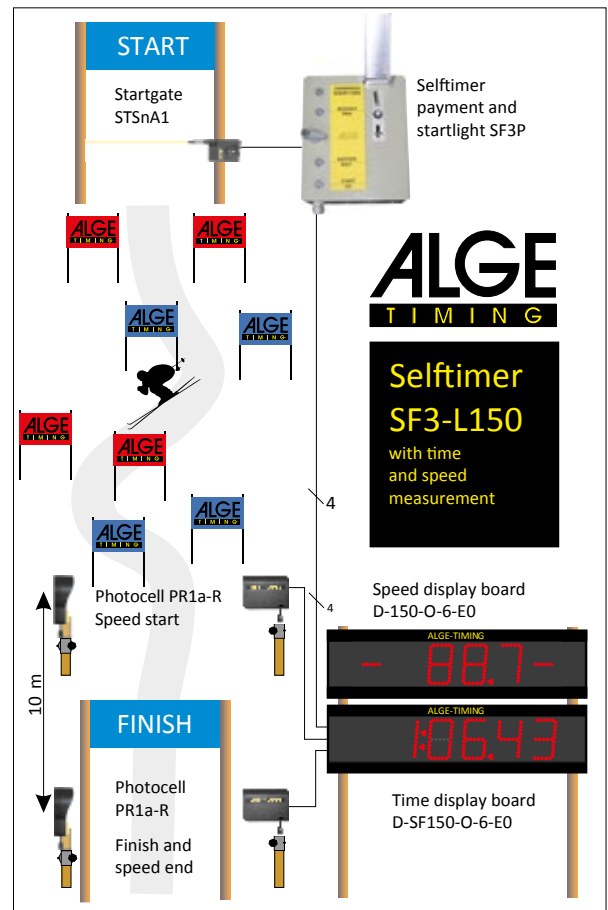
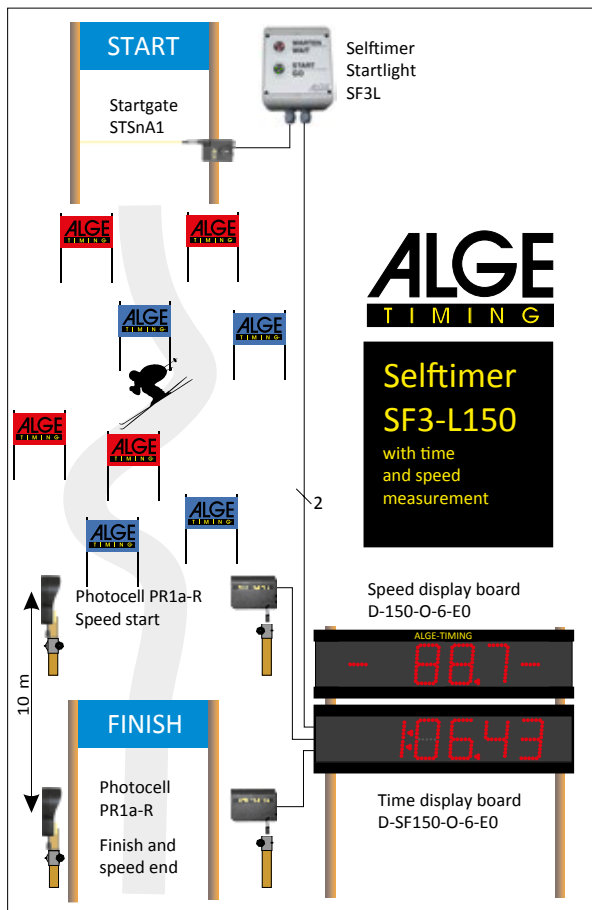
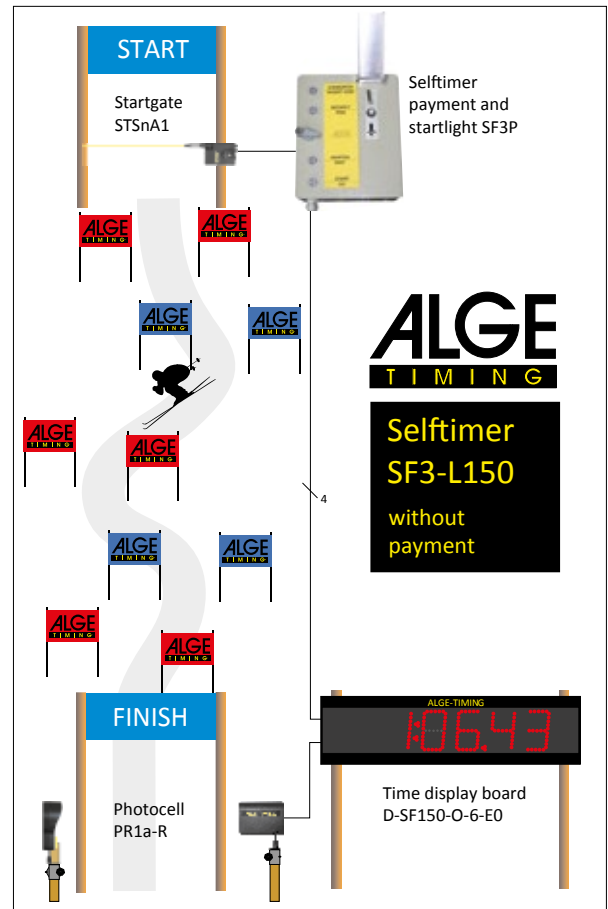
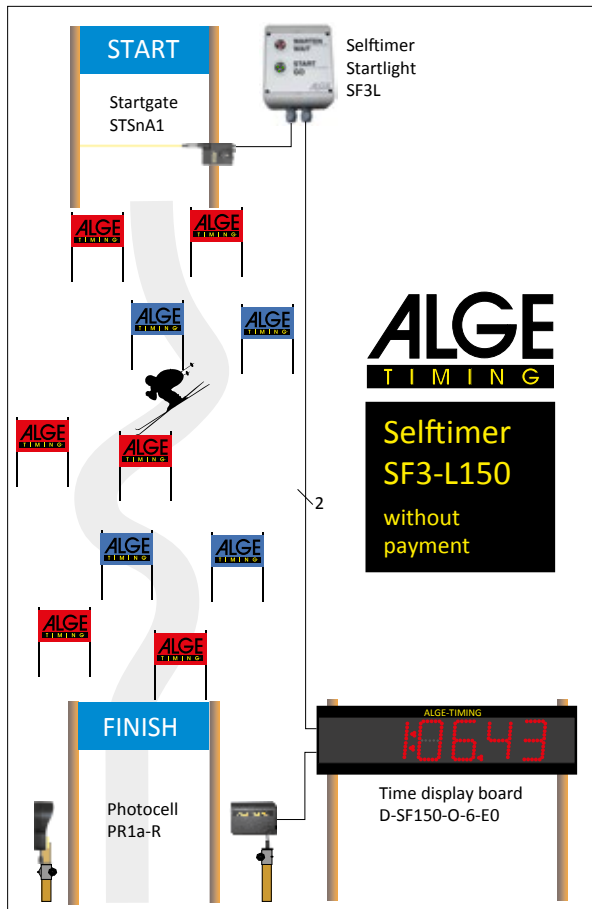



Selftimer SF3 without Coin Insert

Selftimer SF3-L150

- with startgate and photocell
- display board 6-digit, LED, 150 mm digit height
- start light red and green

Selftimer SF3-L250:

- same as SF3-L150
- display board with 250 mm digit height

Selftimer SF3-2L150

- same as SF3-L150
- second photocell for speed measurement at the finish line
- display shows run time and speed alternately

Selftimer SF3-2L250

- same as SF3-2L150
- display board with 250 mm digit height

Selftimer SF3-22L150

- same as SF3-L150
- second photocell for speed measurement at the finish line
- second display board (D-LINE150-O-6-E0) to display speed or runtime

Selftimer SF3-22L250

- same as SF3-22L150
- display board with 250 mm digit height

Selftimer SF3 with Coin Insert

Selftimer SF3-P150

- with startgate and photocell
- display board 6-digit, LED, 150 mm digit height
- start light red and green (start display)
- coin collector with red and green light (coin insert)

Selftimer SF3-P250

- same as SF3-P150
- display board with 250 mm digit height

Selftimer SF3-2P150

- same as SF3-P150
- second photocell for speed measurement at the finish line
- display shows alternatively runtime and speed

Selftimer SF3-2P250

- same as SF3-2P150
- display board with 250 mm digit height

Selftimer SF3-22P150

- same as SF3-P150
- second photocell for speed measurement at the finish line
- second display board (D-LINE150-O-6-E0) to display speed or run time

Selftimer SF3-22P250

- such as SF3-22P150
- display board with 250 mm digit height

Technical Data

| | |
|------------------------|--|
| Power supply: | 100 - 240 VAC and 12 VDC, respectively |
| Power consumption: | max. 20 watts for SF3-L150 or SF3-P150 max. 45 watts for SF3-L250 or SF3-P250 |
| Operating temperature: | -30 °C to +40 °C |
| Time resolution: | 1/100 second |
| Runtime: | 24 hours |
| Time setting: | It is possible to set the minimum and maximum time allowed for a competitor. |

Without a coin collector, a 2-core cable is required between the start and finish, and a 4-core cable with coin collector. The cable from the start to the finish is not included in the scope of delivery and must have a maximum loop resistance of 130 Ohm.



The Permanent Speed Check for Skiers

The ALGE-TIMING Speedy is a permanent speed check for skiers, with which every skier can measure his/her own speed.

A radar measures the speed of an approaching skier and displays the speed on a display board. For the speed measurement a closed slope is recommended. Each skier has to go down the slope individually.

The installation of the radar is very easy on a post at the side of the speed measuring slope. Therefore, the maintenance of the slope is very easy.

The Speedy is used successfully in many ski resorts worldwide. Because of the attraction for skiers it is often installed on less frequented slopes to bring more skiers in that area.

Speedy 150-3-R: LED display board D-LINE250-O-3-E0 with three digits with 150 mm digit height, radar D-RAD and cables

Speedy 250-3-R: LED display board D-LINE250-O-3-E0 with three digits with 250 mm digit height, radar D-RAD and cables

Technical Data

| | |
|------------------------|--|
| Power supply: | 100 - 240 VAC and 12 VDC |
| Power consumption: | max. 17 watts (Speedy 150-3-R) max. 37 watts (Speedy 250-3-R) |
| Operating temperature: | -30 °C to +40 °C |
| Speed: | from 1.0 to 99.9 km/h |
| Measuring unit: | km/h, m/s or mph |

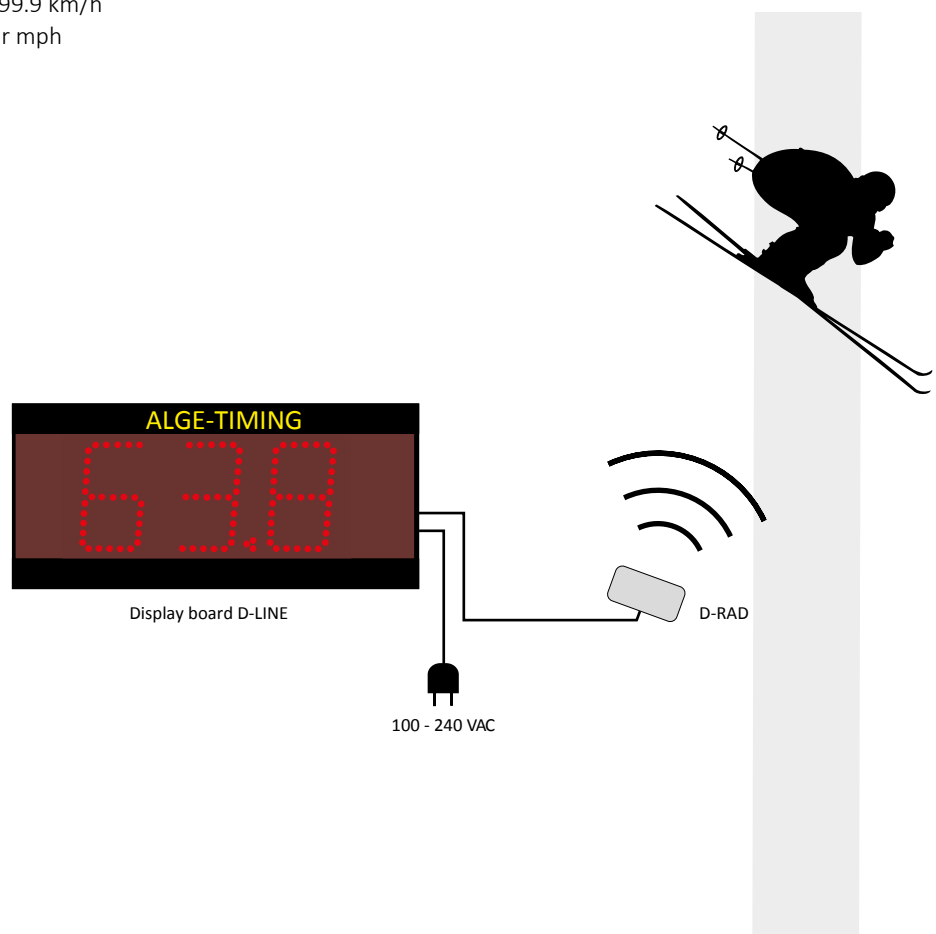

ALPINE SKIING

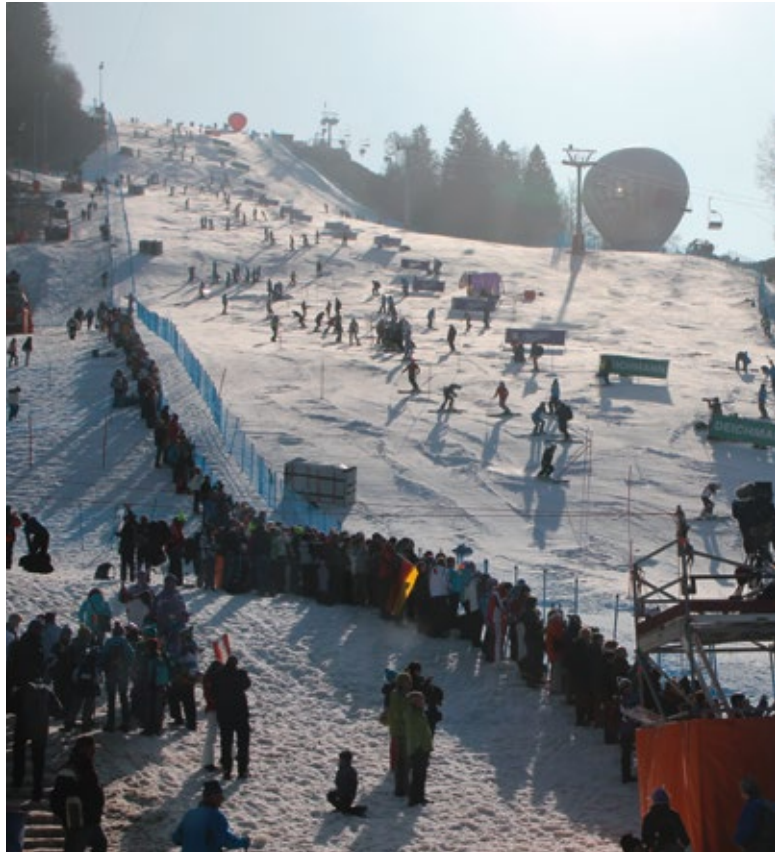



CROSS-COUNTRY SKIING

The various disciplines in cross-country require different timing systems, which meet the special conditions of single start, mass start, pursuit or relay competitions.

For some disciplines a traditional timing system with startgate and photocell is sufficient, photo finish is mainly needed for events with mass arrival. The photo finish produces a photo finish picture of each competitor and allows to check the times, bib numbers or even correct times or arrival order.



decision by photo finish



CROSS-COUNTRY SKIING

Individual Start



The Startclock ASC3 automatically outputs the start interval visually (start light) and acoustically (speaker system) for an easy and regular start procedure. The start is affected by the competitor by triggering the startgate. The start operator and a

finish arrival announcer are in contact with the timing operator using headsets. The timing device is triggered in the finish by a photocell and can be connected to a display board, so the spectators and athletes can see the run time immediately.

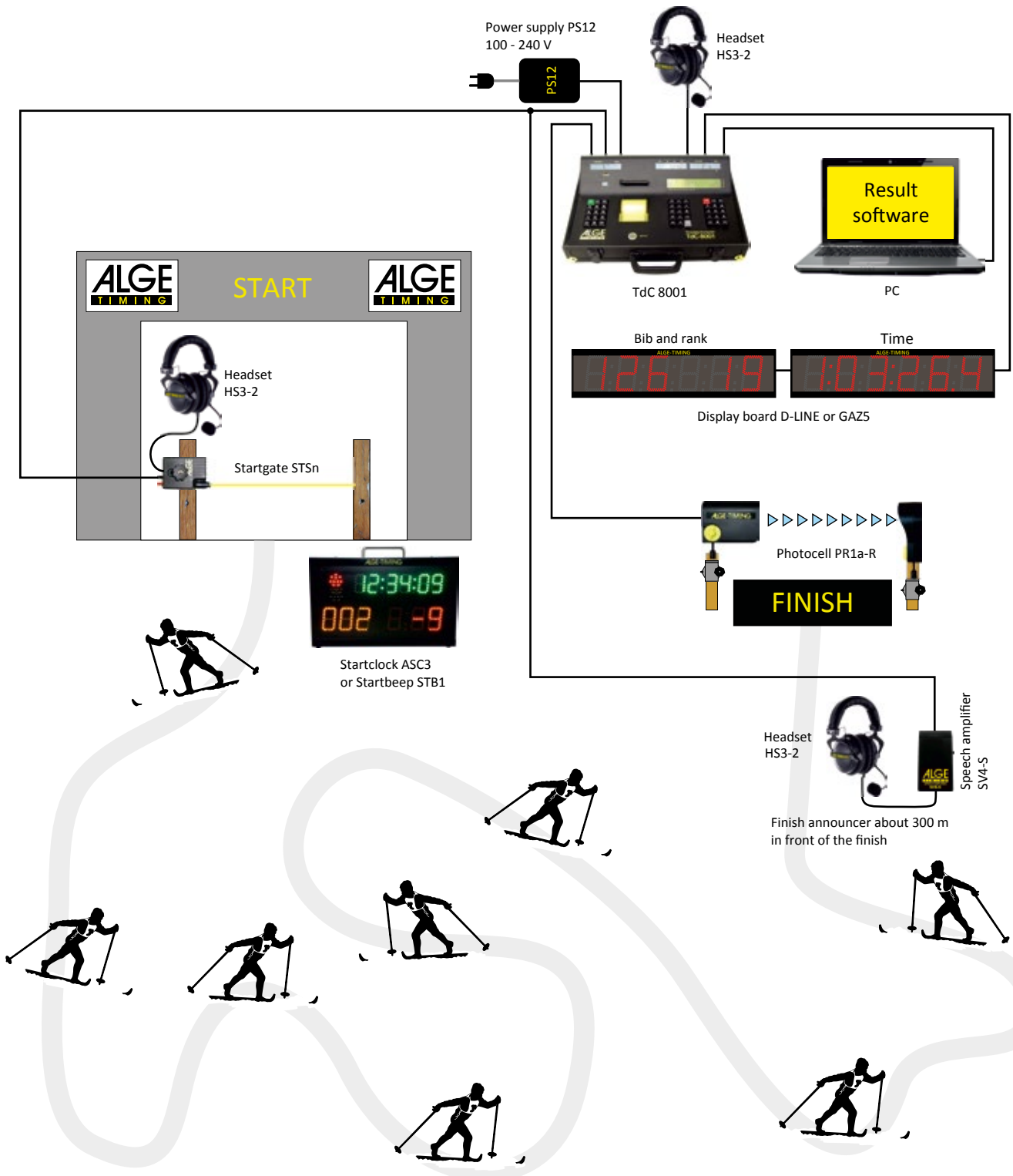



CROSS-COUNTRY SKIING

Pursuit

On a display board at the start the time of day is displayed. This is needed by the racers so that they know when it is their turn to start. The start operator and a finish arrival announcer are in contact with the timing operator using headsets.

Close finish arrivals of competitors can be evaluated on the photo finish picture. The timing device can control a display board, so the spectators and athletes can see the run time immediately.

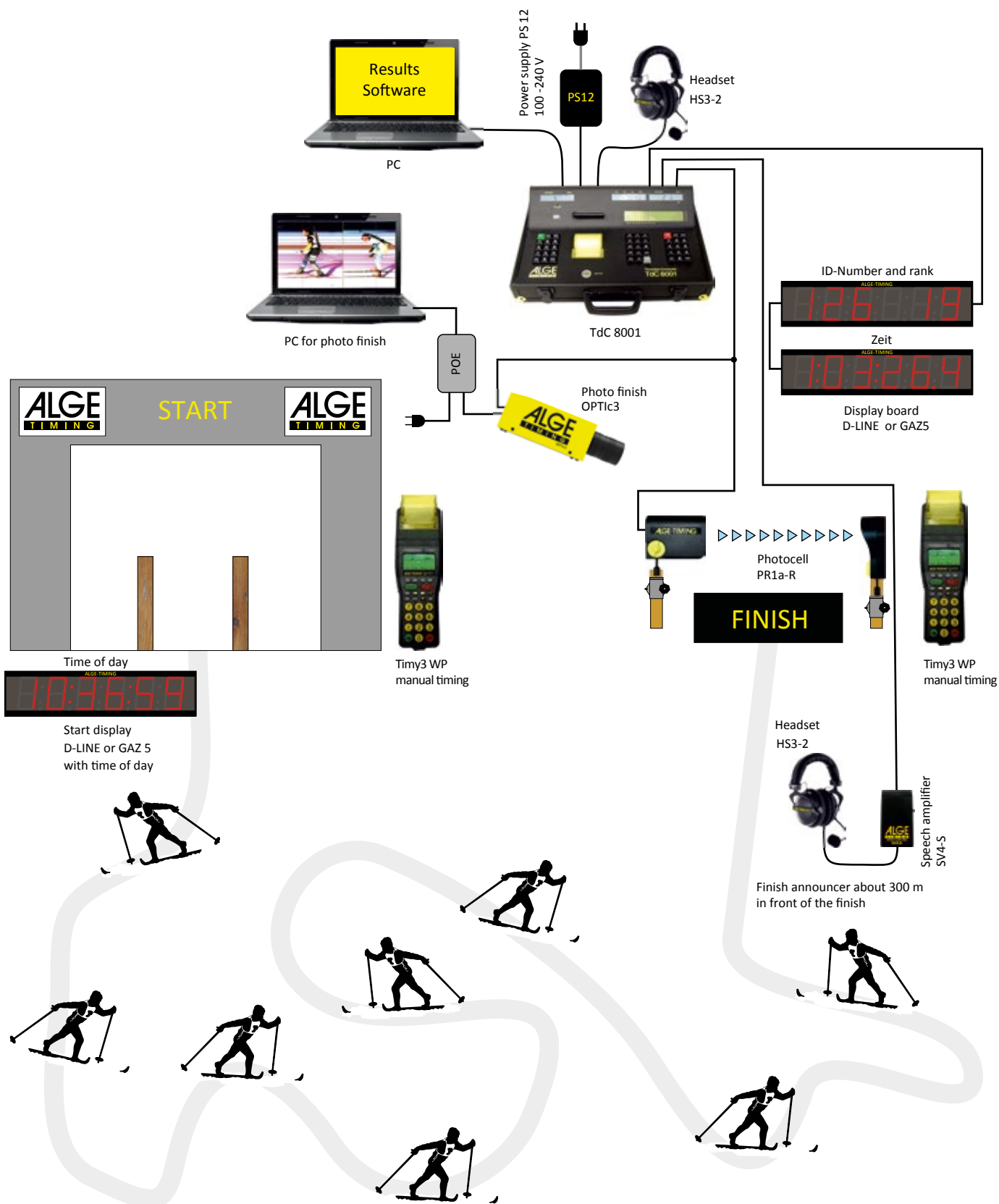

CROSS-COUNTRY SKIING

Relay and Mass Start Competitions



When having races with relay or mass start, an electronic or traditional start gun is used to start the complete field. The start operator and a finish arrival announcer are in contact with the timing operator using headsets. When the photocell PR1a is triggered at the finish line, the arrival at the finish line

is simultaneously recorded with a photo finish system. Tight arrivals or missing bib numbers can be determined with the photo finish picture. The timing device (e.g. TdC8001) can control a display board, so the spectators and athletes can see the run time immediately.

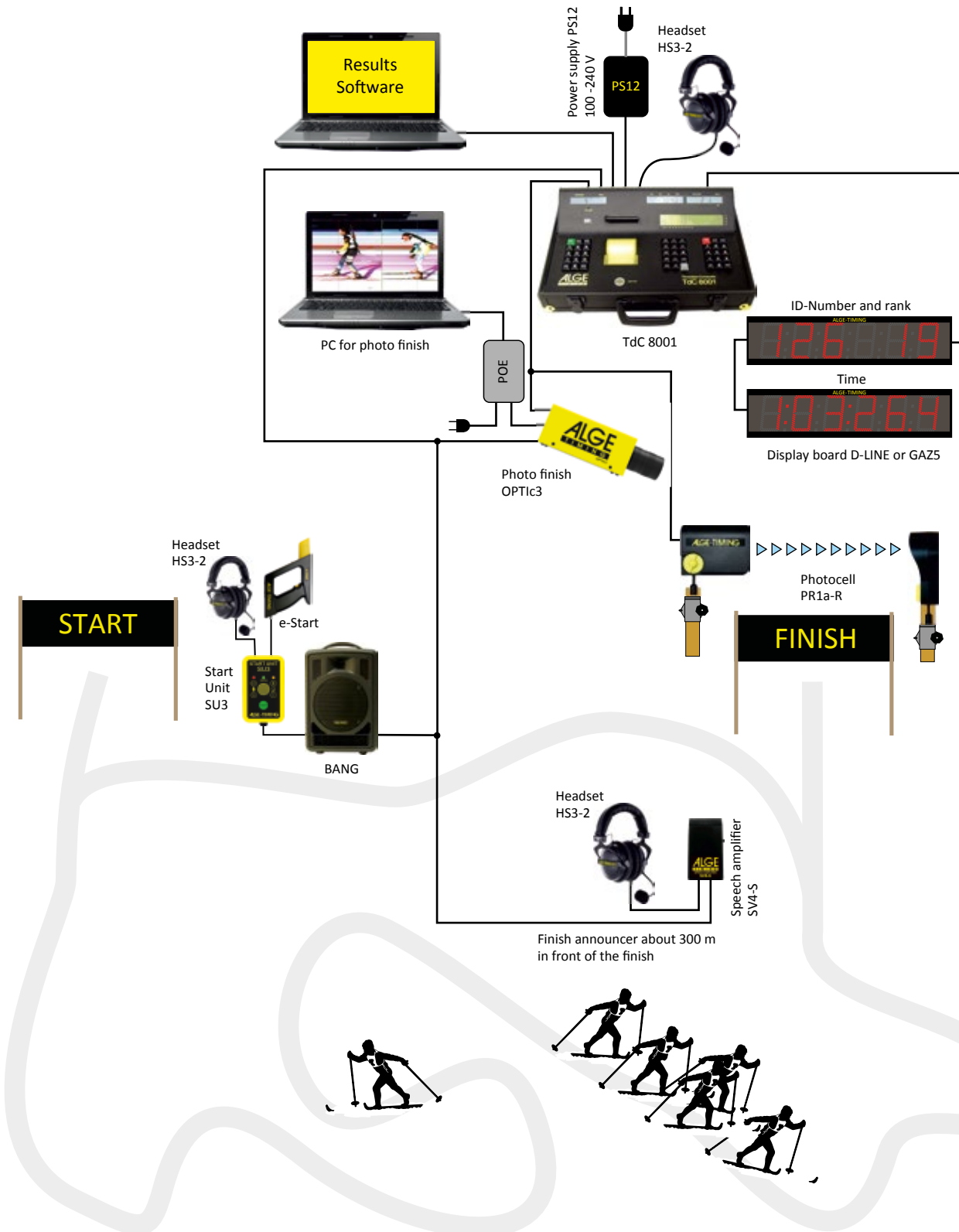



SKI JUMPING

The handling of ski jumping competitions requires the right technical equipment that is very unique.

A system for speed measurement, a start display board D-SDA1S, a wind measuring system, judges terminals and a video width

measuring system might be necessary depending on the importance of the event. Further ALGE-TIMING supplies also the connection boxes for all devices that are used all over the jumping hill for a fix cable installation.



Start Display Board D-SDA1-S

The LED display board D-SDA1 shows the red, yellow and green phase, each with a two-digit countdown with a digit height of 9 cm and a start light.

The system consists of a controller Timy3 W and one or two display boards, which are usually set up at the start and at the coach platform. The time of the countdown phases can be set individually in the controller and stopped at any time. The operation of the lights corresponds with the FIS specifications.

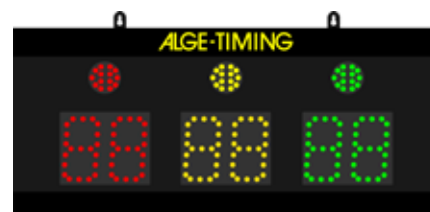

SKI JUMPING

Installation

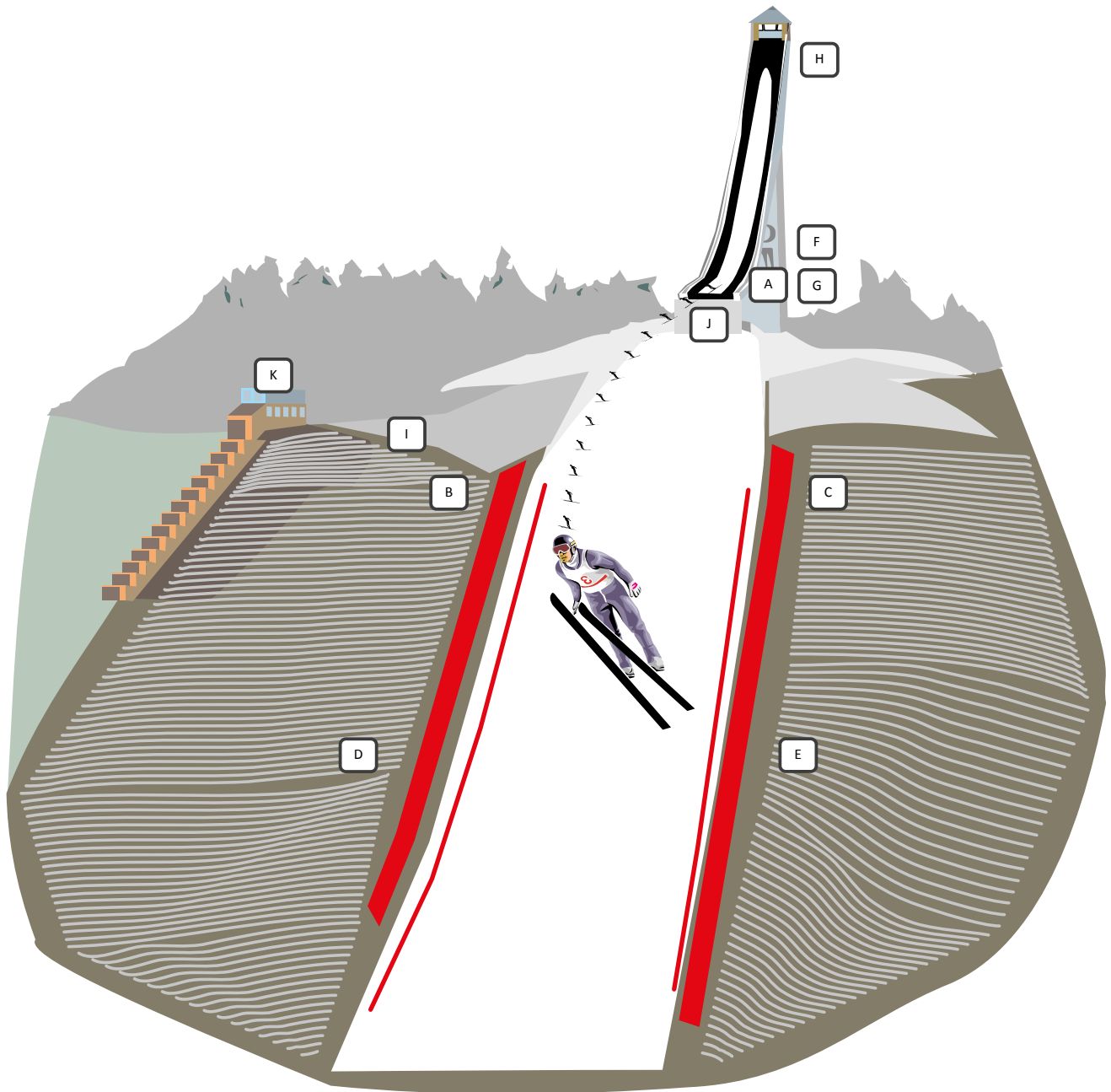

- | | | |
|---------------|----------------|--|
| A - SJB-Wind | take off area | distribution box for anemometer |
| B - SJB-Wind | landing area | distribution box for anemometer 1 - left side |
| C - SJB-Wind | landing area | distribution box for anemometer 1 - right side |
| D - SJB-Wind | landing area | distribution box for anemometer 2 - left side |
| E - SJB-Wind | landing area | distribution box for anemometer 2 - right side |
| F - SJB-Speed | take off area | distribution box for speed trap - photocell 1 |
| G - SJB-Speed | take off area | distribution box for speed trap - photocell 2 |
| H - SJB-SD | starting area | distribution box for start display board |
| I - SJB-TD | trainer sector | distribution box for coach display board |
| J - SJD-Jump | take off area | jumping hill distribution box |
| K - SJD-Cent | judges tower | central distribution box |



SKI JUMPING

Judge Terminals and Speed Measurement

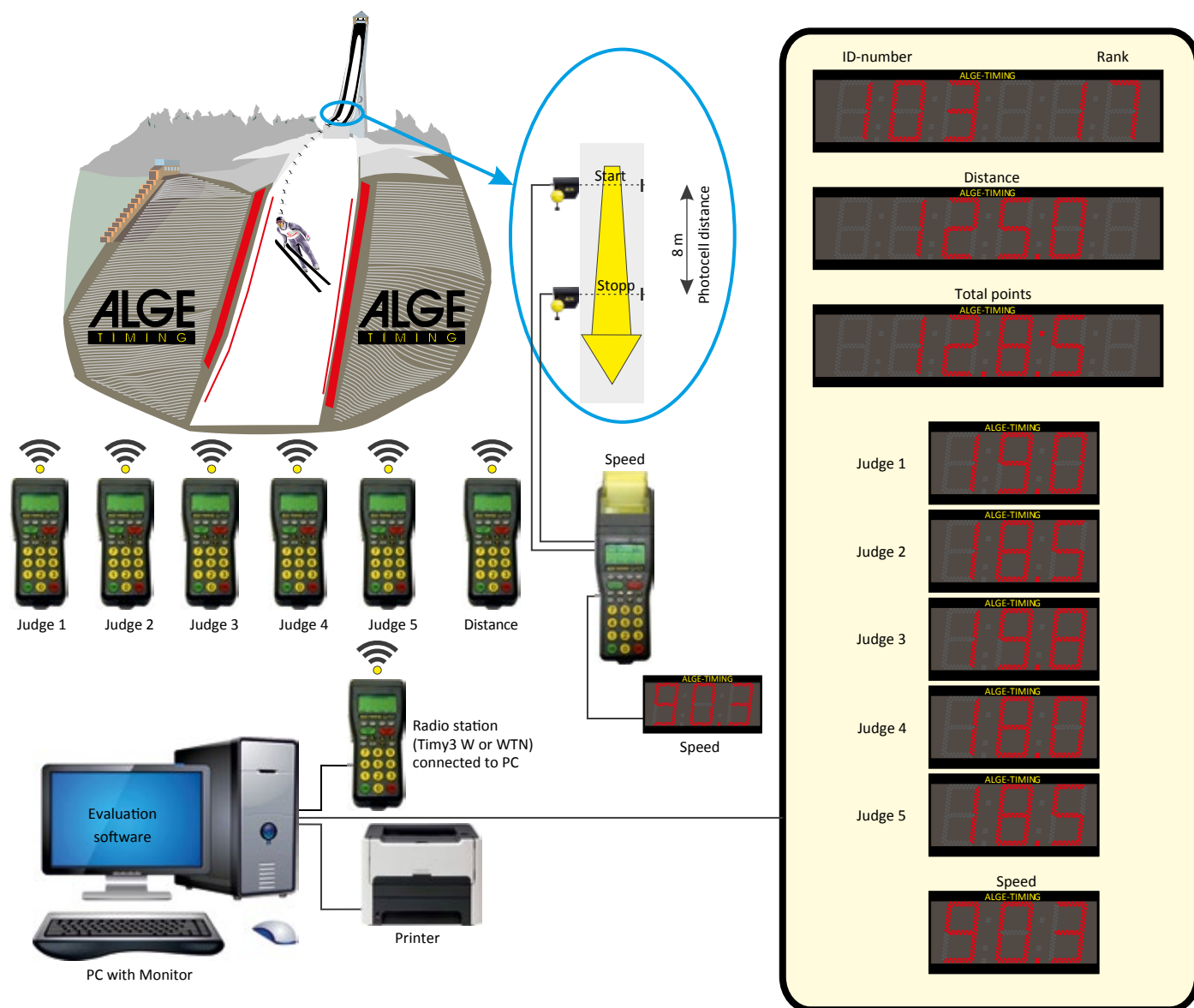

Each judge has a Timy3 W terminal for input of points. The terminals are connected by a Wireless Timing Network (cable free radio network) to each other and the PC. On the PC runs a ski jumping results software. The display boards are controlled directly from the PC.

The speed measurement is also carried out via a Timy3, which directly controls the speed display board and therefore can also be used for training.

The jumping distance can be input manually through a terminal Timy3 or directly at the PC. When using a video distance measuring system, the distance is received online from this system (FIS homologated video distance measuring systems on demand).

SKI JUMPING

System Overview

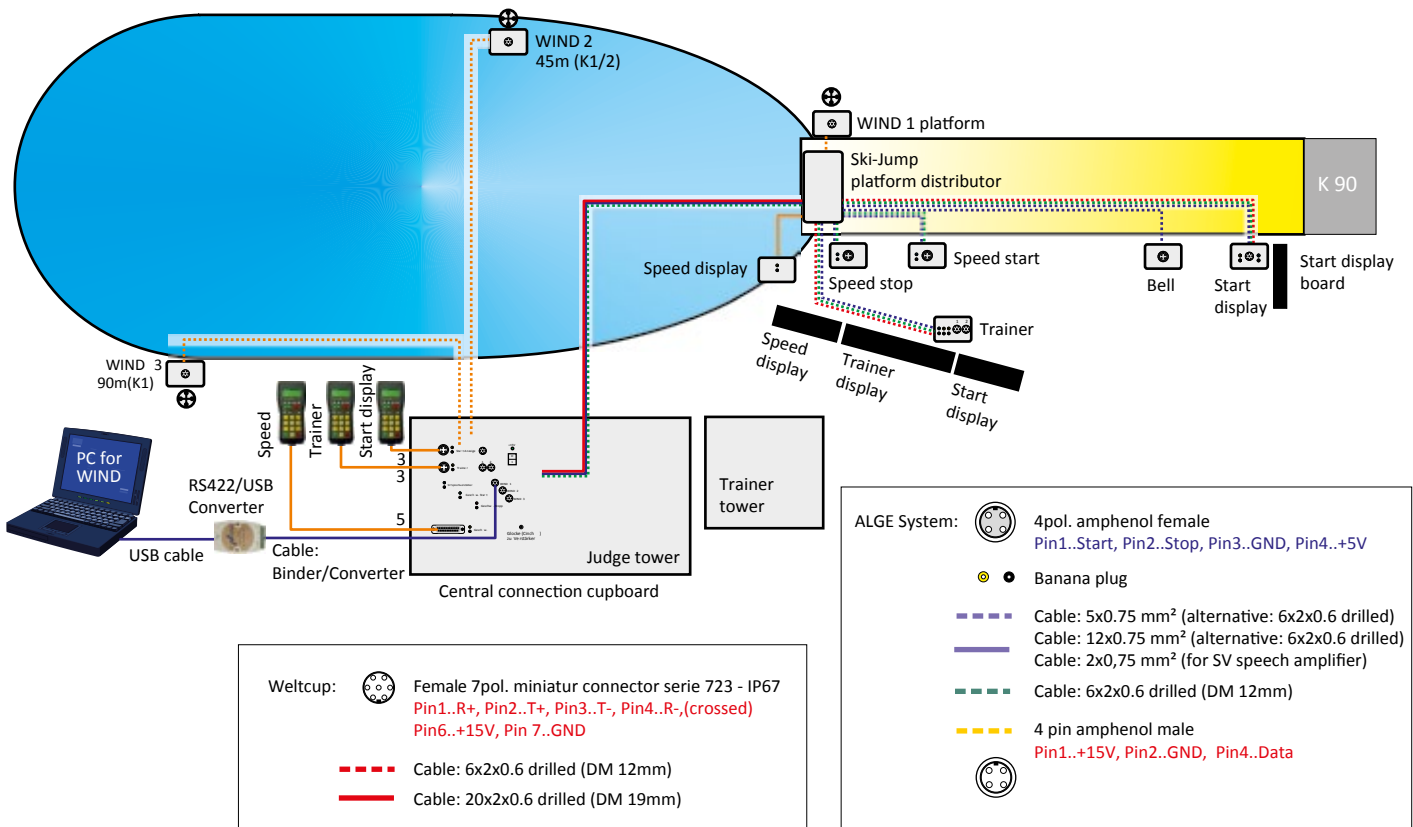
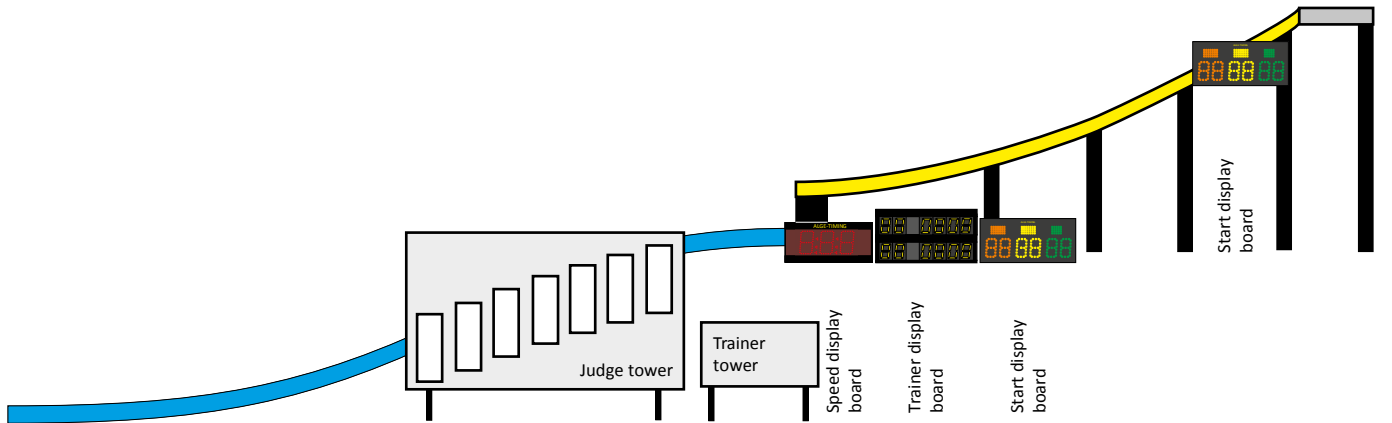

The Anemometer (Wind Speed Indicator)

A three-dimensional anemometer with PC software that indicates the wind direction is needed for the ski jumping hill. Three to seven points exist where a wind anemometer can be installed. For events, one to three anemometers are used depending on the size of the ski jumping hill and the event level. A PC reads the anemometer data and displays the wind information. This PC is situated with the chief of race.





SPEED SKATING

Because of the change of tracks in each lap (inside curve - outside curve), a special program in the timing device TdC8001 is necessary for speed skating.

Moreover, the photocells used for speed skating events have a special floorholder, that can be installed flat on the ice. As a second system (backup) a photo finish is used. It records every finish arrival and in case of a tight finish arrival the photo finish can be evaluated.

The timing device TdC 8001 supplies the display boards with data for both racers:

- bib number and rank
- running time or run time
- lap time

The sketch below shows a timing system for speed skating with the innovative radio system WTN (Wireless Timing Network) from ALGE-TIMING. The electronic start gun e-Start W and photocells are connected with the timing device by radio. Of course, ALGE-TIMING offers as well a system with cables.

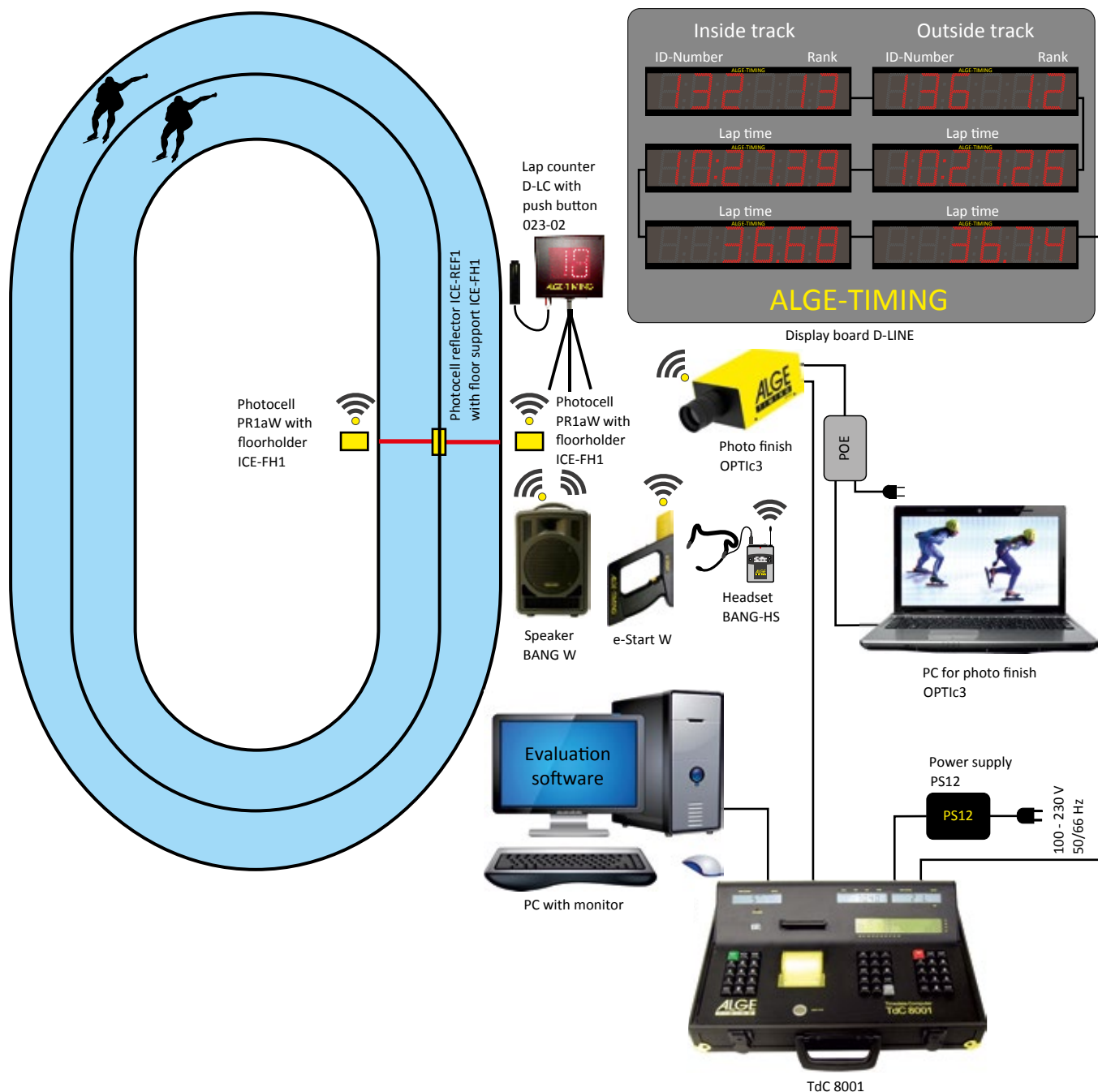



Timing Device TdC8001

For the time measurement in speed skating, the TdC8001 is used with a special software in which one can enter the race distance and the track length. The lane change takes place automatically. The timekeeper must intervene only in case of lapping.

Quad-starts are also possible with two TdC8001s.



PR1a photocell (photoelectric sensor) with floor support ICE-FH1 from the front



PR1a photocell with bottom bracket ICE-FH1 from behind



double reflector ICE-REF1



double reflector ICE-REF1 installed in the floor support ICE-FH1

Photocells for Speed Skating

The ALGE-TIMING standard photocell PR1a can be used with special double reflectors and floorholder for speed skating. For two lanes, two PR1a photocells are needed, the ICE-REF1 double reflector and three floorholders ICE-FH1.

For sprints with three lanes, you additionally need a photocell PR1a, a double reflector ICE-REF1 and a floorholder ICE-FH1.

The photocells are connected to the timing device by cable or radio (model PR1aW).

The floorholders are constructed in a way that the photocells are set flat above the ice. Sharp edges have been avoided so that a racer will not hurt himself in case of an accident.



SHORT TRACK - INLINE SKATING

For short track and inline skating (oval shaped track) the same timing system can be used. An electronic start gun e-Start or e-Start W and speaker system BANG or BANG W is used for the start with cable connection or radio.

For the timing, we recommend two independent systems. The main system is the photo finish system OPTic3. It records the finish arrival. The ranking as well as the accurate time can be

evaluated on the PC. The photo finish camera records when the photocell is interrupted and additionally when the motion detection is activated. The photo finish system controls the display board as well. In addition, different models of lap counters D-LC can be used.

A Timy3 WP serves as backup system to which one manual push button for each racer is connected.

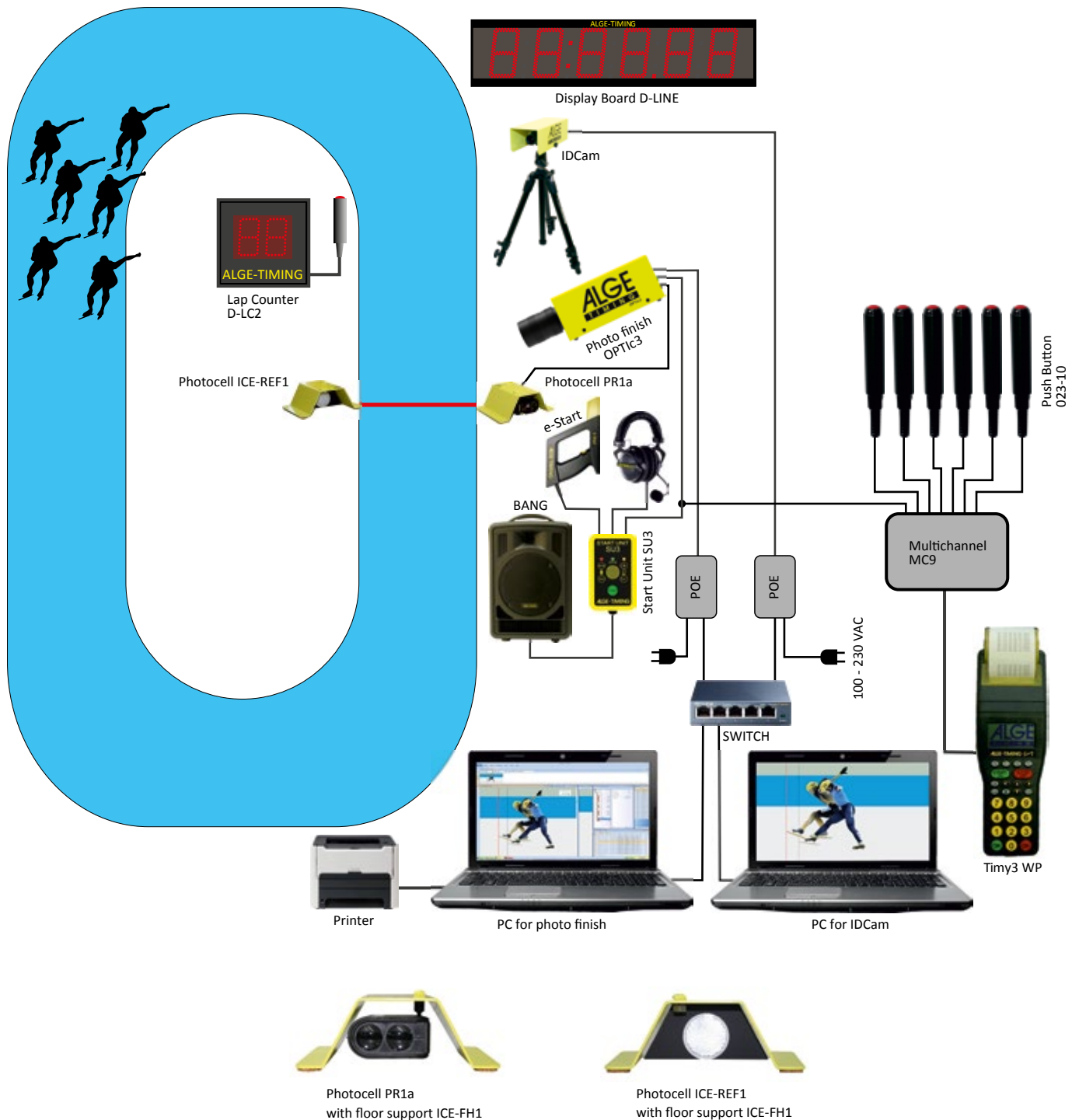

BOB - LUKE - SKELETON



Timing systems for sports that are performed in the ice channel have to meet very specific requirements. There are different starting points and a variety of intermediate times for which ALGE-TIMING has developed unique special solutions that can be modified to meet individual requirements.

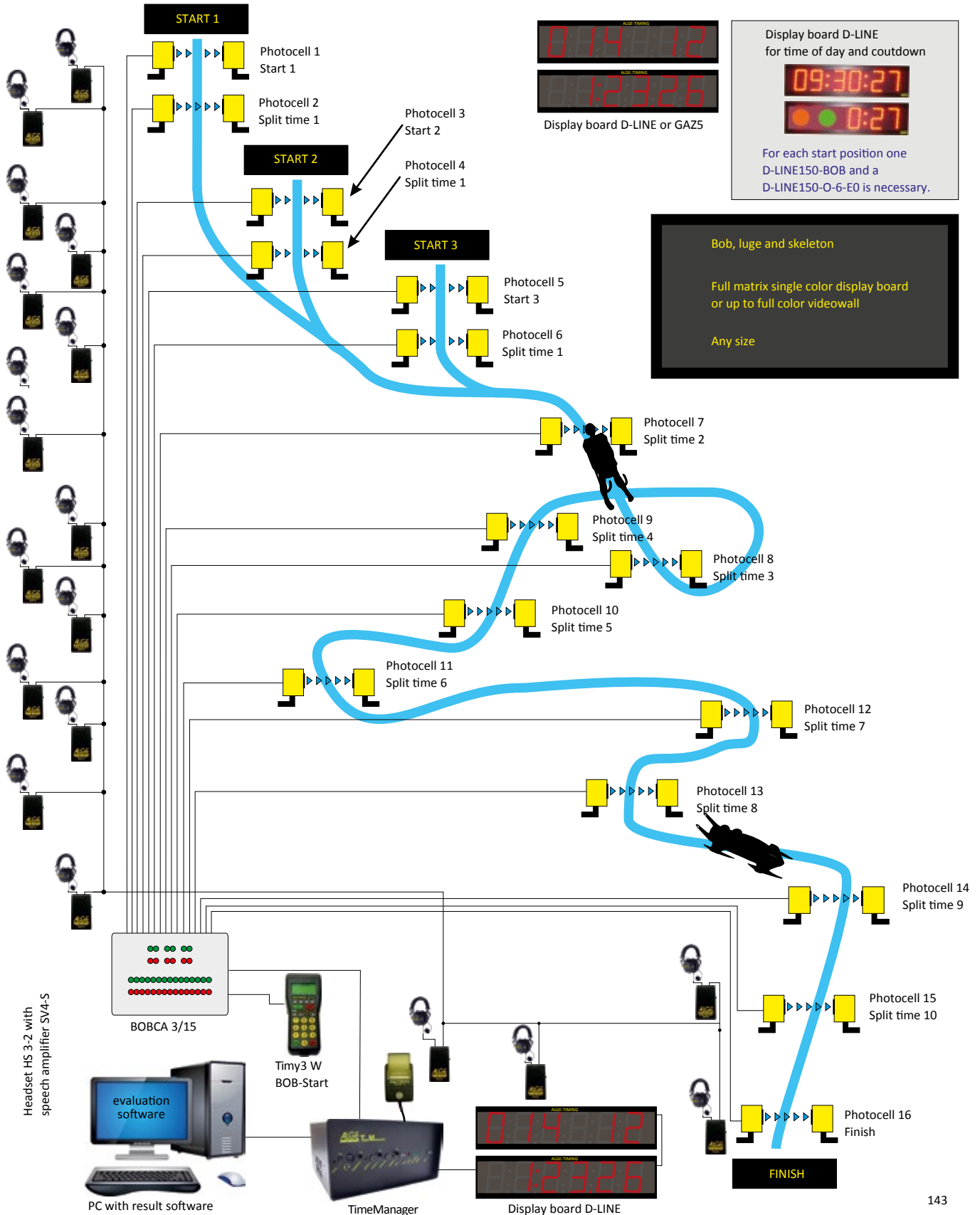



SOCCER / FOOTBALL



SOCCER / FOOTBALL

Scoreboards



Soccer scoreboards are used for small sport facilities, but also in large soccer stadiums and must meet different requirements. In order to guarantee the best possible readability, the scoreboards are available with digit heights from 30 to 150 cm. The brightness of the scoreboard is adapted to the ambient

light, which means that the red LEDs are also very well readable in direct sunlight. In dark light conditions, such as at night, the brightness can be reduced. The scoreboard is controlled by a control console connected by cable or radio.





SOCCKER / FOOTBALL

Scoreboards

These soccer scoreboards count the game time in minutes (two digits) and the score, which is displayed, depending on the model, from 0 to 9 or from 0 to 19 for each team. The display board is controlled by radio using a simple control panel with 3 buttons.

The models are mainly designed for outdoor use and include a soccer scoreboard with radio receiver D-RX and control unit D-CKNF-TXA.

D-LINE300-O-4-E2

Digit height: 30 cm
Readability: up to approx. 150 m
Game time: 2 digits in minutes
Score: per team, from 0 to 9

D-LINE300-O-2 + 2x19-E1

Digit height: 30 cm
Readability: up to approx. 150 m
Game time: 2 digits in minutes
Score: per team, from 0 to 19

D-LINE450-O-4-E2

Digit height: 45 cm
Readability: up to approx. 200 m
Game time: 2 digits in minutes
Score: per team, from 0 to 9

D-LINE450-O-2 + 2x19-E1

Digit height: 45 cm
Readability: up to approx. 200 m
Game time: 2 digits in minutes
Score: per team, from 0 to 19

D-FB300-4-O-WR

Digit height: 30 cm
Readability: up to approx. 150 m
Game time: 2 digits in minutes
Score: per team, from 0 to 9

D-FB300-2 + 2xH-O-WR

Digit height: 30 cm
Readability: up to approx. 150 m
Game time: 2 digits in minutes
Score: per team, from 0 to 19

D-FB300/450-2 + 2xH-O-WR

Digit height: 45 cm and 30 cm
Readability: up to approx. 200 or 150 m
Game time: 2 digits in minutes (45 cm)
Score: per team from 0 to 19 (30 cm)

D-FB450-4-O-WR

Digit height: 45 cm
Readability: up to approx. 200 m
Game time: 2 digits in minutes
Score: per team, from 0 to 9

D-FB450-2 + 2xH-O-WR

Digit height: 45 cm
Readability: up to approx. 200 m
Game time: 2 digits in minutes
Score: per team, from 0 to 19



D-CKNF-TXA



D-LINE450-0-4-E2



D-LINE450-0-2+2x19-E1

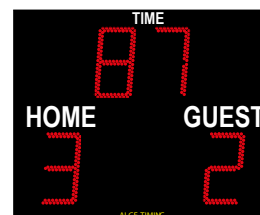

D-FB300-4-O-WR

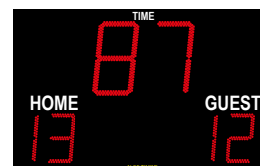

D-FB300-450-2+2xH-O-WR



D-FB450-2+2xH-O-WR

SOCCKER / FOOTBALL

Scoreboards



The scoreboard models show the score and time next to each other (one line). Outside it shows the score and in the middle the time. The models that are used for soccer only consist of four digits, that show the game time in minutes and seconds. The models that are for soccer and athletics have six digits. When used for athletics it shows the run time in minutes, seconds and 1/100th. The score for each team is from 0 to 9 or 0 to 19 depending on the model.

The controller has an integrated display. The standard model needs a cable between the scoreboard and the controller. On request, the scoreboard is controlled by a radio. The scoreboard is designed for outdoor use and figure heights of 30 and 45 cm are available.

D-LINE300-O-6-E2-T

Digit height: 30 cm
Readability: up to 150 m
Game time: 4 digits in minutes and seconds
Score: per team, from 0 to 9

D-LINE450-O-6-E2-T

Digit height: 45 cm
Readability: up to 200 m
Game time: 4 digits in minutes and seconds
Score: per team, from 0 to 9

D-LINE300-O-4 + 2 x 19-E1

Digit height: 30 cm
Readability: up to 150 m
Game time: 4 digits in minutes and seconds
Score: per team, from 0 to 19

D-LINE450-O-4 + 2 x 19-E1

Digit height: 45 cm
Readability: up to 200 m
Game time: 4 digits in minutes and seconds
Score: per team, from 0 to 19

D-LINE300-O-8A-E2 (also for athletics)

Digit height: 30 cm
Readability: up to 150 m
Game time: 6 digits in minutes, seconds and 1/100 seconds
Score: per team, from 0 to 9

D-LINE450-O-8A-E2 (also for athletics)

Digit height: 45 cm
Readability: up to 200 m
Game time: 6 digits in minutes, seconds and 1/100 seconds
Score: per team, from 0 to 9

D-LINE300-O-6 + 2x19-E1 (also for athletics)

Digit height: 30 cm
Readability: up to 150 m
Game time: 6 digits in minutes, seconds and 1/100 seconds
Score: per team, from 0 to 19

D-LINE450-O-6 + 2x19-E1 (also for athletics)

Digit height: 45 cm
Readability: up to 200 m
Game time: 6 digits in minutes, seconds and 1/100 seconds
Score: per team, from 0 to 19



D-LINE300-O-6-E2-T



D-LINE450-O-6-E2-T



D-LINE300-O-4+2x19-E1



D-LINE450-O-4+2x19-E1



D-LINE300-O-8A-E2 in soccer mode



D-LINE300-O-8A-E2 in athletics mode

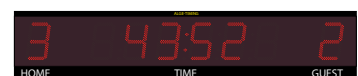

D-LINE450-O-8A-E2 in soccer mode



D-LINE450-O-8A-E2 in athletics mode



D-LINE300-O-6 + 2 x 10-E1 in soccer mode



D-LINE450-O-6 + 2 x 19-E1 in athletics mode



SOCCKER / FOOTBALL

Scoreboards

These soccer scoreboards display the game time with 4 digits, in minutes and seconds. Some models can display the time with 6-digits and are usable as well for athletics competitions. Depending on the model, the score will be 0 to 9 or 0 to 19, per team.

The controller has an integrated display. The standard model needs a cable between the scoreboard and the controller. On request, the scoreboard is controlled by a radio. The scoreboard is designed for outdoor use and figure heights of 30, 45, 60, 100 and 150 cm are available.

D-FB3-19-300

Digit height: 30 cm
Readability: up to 150 m
Game time: 4 digits in minutes and seconds
Score: per team, from 0 to 19

D-FB3-19-600

Digit height: 60 cm (23.6 inches)
Readability: up to 250 m
Game time: 4 digits in minutes and seconds
Score: per team, from 0 to 19

D-FB3-19-A-300

Digit height: 30 cm
Readability: up to 150 m
Game time: 6 digits in minutes, seconds and 1/100 seconds
Score: per team, from 0 to 19

D-FB3-19-A-600

Digit height: 60 cm (23.6 inches)
Readability: up to 250 m
Game time: 6 digits in minutes, seconds and 1/100 seconds
Score: per team, from 0 to 19

D-FB3-19-450

Digit height: 45 cm
Readability: up to 200 m
Game time: 4 digits in minutes and seconds
Score: per team, from 0 to 19

D-FB3-19-1000

Digit height: 100 cm (39.4 inches)
Readability: up to 400 m
Game time: 4 digits in minutes and seconds
Score: per team, from 0 to 19

D-FB3-19-A-450

Digit height: 45 cm
Readability: up to 200 m
Game time: 6 digits in minutes, seconds and 1/100 seconds
Score: per team, from 0 to 19

D-FB3-19-1500

Digit height: 150 cm
Readability: up to 600 m
Game time: 4 digits in minutes and seconds
Score: per team, from 0 to 19

D-FB3-19-600/450

Digit height: 60 cm and 45 cm
Readability: up to 250 m or 200 m
Game time: 4 digits in minutes and seconds
Score: per team, from 0 to 19



D-FB3-19-450



D-FB3-19-A-450 with game display for soccer



D-FB3-19-A-450 with time for light athletics



D-FB3-19-600-450



SOCCER / FOOTBALL

Scoreboards



All soccer scoreboards contain a controller. The controller can differ from model to model and is expandable on request.

Controller with integrated display for scoreboards that show the time with at least 4-digits

D-CKN: standard control for all models with a minimum 4-digit time display

D-CKN-TXA: expandable alternative - integrated - rechargeable battery and radio so that the operator can move freely in the soccer field



D-CKN

D-CKN-TXA

Controller without display with 3 buttons and integrated radio for scoreboards that show the time with 2-digits

D-CKNF-TXA: standard controller for scoreboards that display the time on 2-digits, complete with integrated radio and battery



D-CKNF-TXA

Radio for Soccer Scoreboards

When switching from controller D-CKN to a controller with integrated radio, it needs as well a radio receiver D-RX (surcharge) for the scoreboard.

Attention: Radio controlled scoreboards also require a power supply from mains.

Accessories for Soccer Scoreboards

DCF radio receiver D-DCF: The time is always precise to the second and it switches automatically between summer and winter time. Reception: Central Europe

GPS receiver D-GPS: The time is always precise to the second and it switches automatically between summer and winter time. Reception: Worldwide

Temperature sensor D-AT: The temperature is displayed when the scoreboard is not needed for football. It is possible to display the time of day and temperature alternating.

Light sensor D-LS: The brightness is automatically adjusted to the ambient light conditions.

Models with text display: It is possible to add a matrix display to the soccer scoreboard. Depending on the size of the matrix display board D-RTNM, it can display, e.g. the club names or advertising.



example: D-FB3-19-450 and D-RTNM matrix



SOCCKER / FOOTBALL

Scoreboards

Assembly

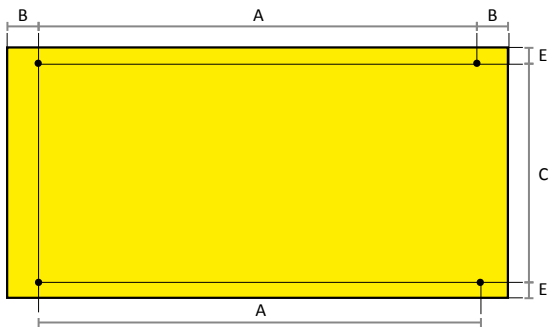

D-FB3 19-xxx mounting holes - all with M6

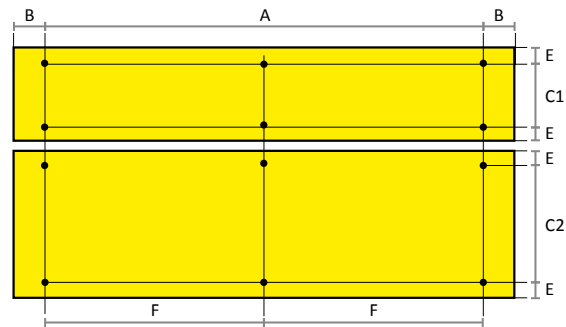

D-FB3 19-xxx mounting holes - all with M6

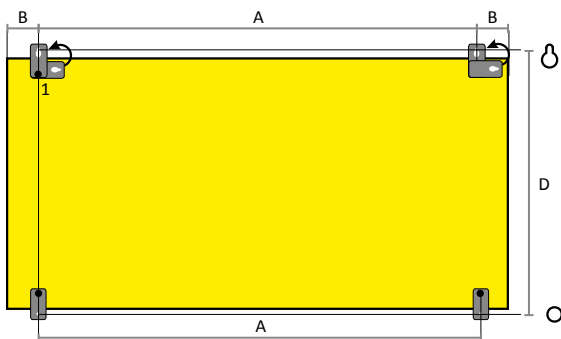

D-FB3 19-xxx mounting with lugs

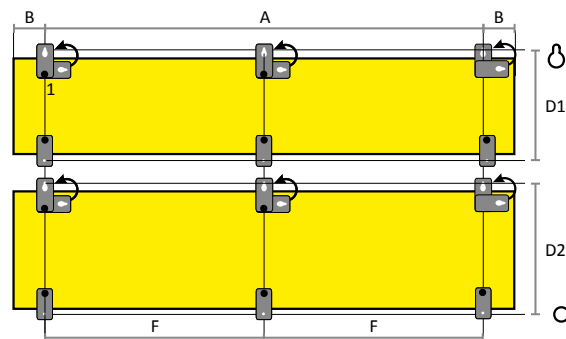

D-FB3 19-xxx mounting with lugs

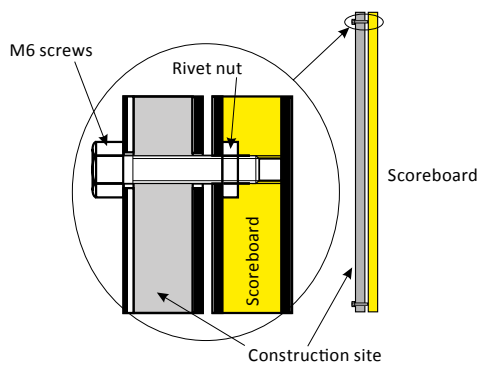

Mounting on the same mounting structure, fastened with M6 screws from the back

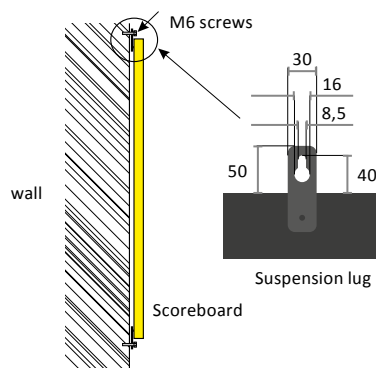

Mounting on wall, fastened with M6 screws over lugs

| Matching D-RTNM Matrix Boards to the Models D-FB3 | D-FB3-19-300 | D-FB3-19-450 | D-FB3-19-600/450 | D-FB3-19-600 | D-FB3-19-1000 | D-FB3-19-1500 | D-FB3-19-A-300 | D-FB3-19-A-450 | D-FB3-19-A-600 |
|---|--------------|--------------|------------------|--------------|---------------|---------------|----------------|----------------|----------------|
| 1 line, 7 pixels height | P3-7x56 | P4-7x80 | P4-7x88 | P4-7x104 | P7-7x96 | P7-7x128 | P3-7x56 | P4-7x80 | P4-7x104 |
| 1 line, 8 pixels height | P3-8x56 | P4-8x80 | P4-8x88 | P4-8x104 | P7-8x96 | P7-8x128 | P3-8x56 | P4-8x80 | P4-8x104 |

You can add a matching matrix display board to the soccer scoreboard. Thus, additional information, such as team names, scorer, lineups, animations, etc. can also be displayed.

SOCCKER / FOOTBALL

Scoreboards



Dimensions

| Model | Parts of the Scoreboard | Length* | Height* | Depths* | Weight** | Mounting holes or hangers | A* | B* | C, C1, C2* | D, D1, D2* | E* | F* | Digit height* | Caption height* |
|------------------------|-------------------------|---------|-----------------|---------|----------|---------------------------|-------|-----|-----------------|-----------------|----|-------|---------------|-----------------|
| D-LINE300-O-4-E2 | 1 | 1,800 | 550 | 70 | 20 | 4 | 1,400 | 200 | 480 | 590 | 35 | - | 300 | 80 |
| D-LINE300-O-2+2x19-E1 | 1 | 1,800 | 550 | 70 | 20 | 4 | 1,400 | 200 | 480 | 590 | 35 | - | 300 | 80 |
| D-LINE300-O-6-E2-T | 1 | 2,300 | 550 | 70 | 25 | 4 | 1,900 | 200 | 480 | 590 | 35 | - | 300 | 80 |
| D-LINE300-O-4+2x19-E1 | 1 | 2,300 | 550 | 70 | 25 | 4 | 1,900 | 200 | 480 | 590 | 35 | - | 300 | 80 |
| D-LINE300-O-8A-E2 | 1 | 2,800 | 550 | 70 | 30 | 4 | 2,400 | 200 | 480 | 590 | 35 | - | 300 | 80 |
| D-LINE300-O-6+2x19-E1 | 1 | 2,800 | 550 | 70 | 30 | 4 | 2,400 | 200 | 480 | 590 | 35 | - | 300 | 80 |
| D-LINE450-O-4-E2 | 1 | 2,500 | 800 | 70 | 40 | 4 | 2,100 | 200 | 730 | 840 | 35 | - | 450 | 130 |
| D-LINE450-O-2+2x19-E1 | 1 | 2,500 | 800 | 70 | 40 | 4 | 2,100 | 200 | 730 | 840 | 35 | - | 450 | 130 |
| D-LINE450-O-6-E2-T | 1 | 3,300 | 800 | 70 | 52 | 4 | 2,900 | 200 | 730 | 840 | 35 | - | 450 | 130 |
| D-LINE450-O-4+2x19-E1 | 1 | 3,300 | 800 | 70 | 52 | 4 | 2,900 | 200 | 730 | 840 | 35 | - | 450 | 130 |
| D-LINE450-O-8A-E2 | 1 | 4,100 | 800 | 70 | 66 | 4 | 3,700 | 200 | 730 | 840 | 35 | - | 450 | 130 |
| D-LINE450-O-6+2x19-E1 | 1 | 4,100 | 800 | 70 | 66 | 4 | 3,700 | 200 | 730 | 840 | 35 | - | 450 | 130 |
| D-LINE600-O-4-E2 | 1 | 3,300 | 1,100 | 70 | 73 | 4 | 2,900 | 200 | 1,030 | 1,140 | 35 | - | 600 | 180 |
| D-LINE600-O-2+2x19-E1 | 1 | 3,300 | 1,100 | 70 | 73 | 4 | 2,900 | 200 | 1,030 | 1,140 | 35 | - | 600 | 180 |
| D-LINE600-O-6-E2-T | 1 | 4,200 | 1,100 | 70 | 92 | 4 | 3,800 | 200 | 1,030 | 1,140 | 35 | - | 600 | 180 |
| D-LINE600-O-4+2x19-E1 | 1 | 4,200 | 1,100 | 70 | 92 | 4 | 3,800 | 200 | 1,030 | 1,140 | 35 | - | 600 | 180 |
| D-LINE600-O-8A-E2 | 1 | 5,100 | 1,100 | 70 | 112 | 4 | 4,700 | 200 | 1,030 | 1,140 | 35 | - | 600 | 180 |
| D-LINE600-O-6+2x19-E1 | 1 | 5,100 | 1,100 | 70 | 112 | 4 | 4,700 | 200 | 1,030 | 1,140 | 35 | - | 600 | 180 |
| D-FB300-4-O-WR | 1 | 1,100 | 900 | 70 | 20 | 4 | 700 | 200 | 830 | 940 | 35 | - | 300 | 80 |
| D-FB300-2+2xH-O-WR | 1 | 1,100 | 900 | 70 | 20 | 4 | 700 | 200 | 830 | 940 | 35 | - | 300 | 80 |
| D-FB300/450-2+2xH-O-WR | 1 | 1,600 | 1,000 | 70 | 32 | 4 | 1,200 | 200 | 930 | 1,040 | 35 | - | 300/ 450 | 80 |
| D-FB450-4-O-WR | 1 | 1,700 | 1,200 | 70 | 40 | 4 | 1,300 | 200 | 1,130 | 1,240 | 35 | - | 450 | 100 |
| D-FB450-2+2xH-O-WR | 1 | 1,700 | 1,200 | 70 | 40 | 4 | 1,300 | 200 | 1,130 | 1,240 | 35 | - | 450 | 100 |
| D-FB3-19-300 | 1 | 1,200 | 850 | 70 | 21 | 4 | 800 | 200 | 680 | 890 | 35 | - | 300 | 50 |
| D-FB3-19-A-300 | 1 | 1,700 | 850 | 70 | 33 | 4 | 1,300 | 200 | 680 | 890 | 35 | - | 300 | 50 |
| D-FB3-19-450 | 1 | 1,900 | 1,400 | 70 | 55 | 4 | 1,500 | 200 | 1,350 | 1,460 | 35 | - | 450 | 150 |
| D-FB3-19-A-450-1 | 1 | 2,490 | 1,400 | 70 | 70 | 6 | 2,090 | 200 | 1,330 | 1,440 | 35 | 1,045 | 450 | 150 |
| D-FB3-19-A-450 | 1 | 2,490 | 1,400 | 70 | 70 | 6 | 2,090 | 200 | 1,330 | 1,440 | 35 | 1,045 | 450 | 150 |
| D-FB3-19-600/450 | 2 | 2,000 | 600/ 1,000 | 70 | 64 | 2x6 | 1,600 | 200 | 530/ 930 | 640/ 1,040 | 35 | 800 | 600/ 450 | 200 |
| D-FB3-19-600 | 2 | 2,490 | 800/ 1,000 | 70 | 90 | 2x6 | 2,090 | 200 | 730/ 930 | 840/ 1,040 | 35 | 1,045 | 600 | 200 |
| D-FB3-19-A-600 | 2 | 3,400 | 800/ 1,000 | 70 | 120 | 2x6 | 3,000 | 200 | 730/ 930 | 840/ 1,040 | 35 | 1,045 | 600 | 200 |
| D-FB3-19-1000 | 2 | 3,800 | 1,200/ 1,500 | 70 | 205 | 2x6 | 3,400 | 200 | 1,130/ 1,430 | 1,240/ 1,540 | 35 | 1,700 | 1,000 | 250 |
| D-FB3-19-1500 | 2 | 5,200 | 1,800/ 2,200 | 70 | 416 | 2x6 | 4,800 | 200 | 1,730/ 2,130 | 1,840/ 2,240 | 35 | 2,400 | 1,500 | 300 |

* Dimensions in millimeter, ** Weight in kilo



BALL SPORTS

Ball Speed BS-R

The Ball Speed Radar BS-R

The ball speed radar BS-R can detect speeds up to 300 km/h and is used in various sports to measure the speed of balls, pucks and other moving objects. The radar can be mounted behind a goal and measure through the net. The measured speed is

shown on a display board. The ball speed radar BS-R is quick and easy to set up and thanks to its compact, rugged construction it is weatherproof and suitable for outdoor use.

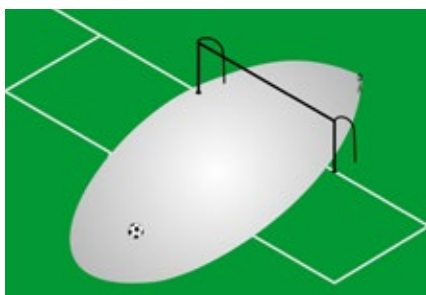

Approximate measuring range for football



Components of the System

Radar Sensor

Radar photocell offering exact measurements, despite large measuring range

It makes exact measurements, although it has a large measuring range.

| | |
|---------------------|---|
| Radar frequency: | 24,125 GHz |
| Transmission power: | < 5 mW |
| Speed measurement: | 10 to 300 km/h |
| Measuring angle: | approx. 40 °C |
| Accuracy: | less than 100 km/h: approx. +/- 2 km/h more than 100 km/h: approx. 2% |



Display Board D-LINE150-O-3-E0

- 3 red LED digits
- digit height 150 mm (readable up to 70 m)
- best readability even in direct sunlight
- weatherproof aluminum housing
- for speed indication
- integrated power supply (100 to 240 VAC)
- connection to radar sensor with integrated power supply

Model Selection

Ballspeed BS-R150

- 3-digit scoreboard, 150 mm digit height
- radar sensor
- tripod for radar

Ballspeed BS-R250

- 3-digit scoreboard, 250 mm digit height
- radar sensor
- tripod for radar



Display Board D-LINE250-O-3-E0

The difference to the display board D-LINE150-O-3-E0 is the figure height of the LED-digit that is for this model 250 mm (readable up to 120 m).

Tripod TRI128

for mounting the radar sensor

Floor Support FH

for mounting the scoreboard

The following sports are supported

- soccer / football
- handball
- ice hockey
- bandy
- american football





TENNIS

LED Scoreboards

ALGE-TIMING tennis scoreboards have been used for many years in various tournaments, from the local club tournament to the big events such as the GP tournament or the Davis Cup. Control takes place via a terminal with intelligent software in which it is entered who makes the point. The rest is done by the controller. At the status of 6 to 6 in the set, it can be decided whether there is a tie-break or if the set will be played out.

LED tennis scoreboards work silently in comparison to electro-magnetic display panels. The brightness of the display can be adjusted. Both, direct sunlight and dark areas in a hall are no problem. It guarantees optimum readability in all light conditions.

LED Tennis Scoreboard Models

Tennis Scoreboard D-TA615

Digit height: 150 mm
Max. readability: up to 70 m
Game display: 3 records

Tennis Scoreboard D-TA625

Digit height: 250 mm
Max. readability: up to 120 m
Game display: 3 records

Tennis Scoreboard D-TA645

Digit height: 450 mm
Max. readability: up to 200 m
Game display: 3 records

Tennis Scoreboard D-TA815

Digit height: 150 mm
Max. readability: up to 70 m
Game display: 5 sets

Tennis Scoreboard D-TA825

Digit height: 250 mm
Max. readability: up to 120 m
Game display: 5 sets

Tennis Scoreboard D-TA845

Digit height: 450 mm max.
Max. readability: up to 200 m
Game display: 5 sets

Tennis Scoreboard D-TA815-T415

Digit height: 150 mm
Max. readability: up to 70 m
Game display: 5 sets
Time display: hours and minutes

Tennis Scoreboard D-TA825-T415

Digit height: 250 mm
Max. readability: up to 120 m
Game display: 5 sets
Time display: hours and minutes with 15 cm digits

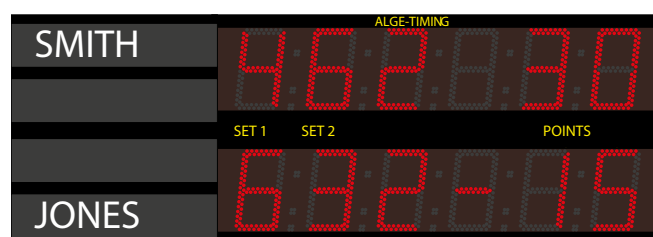

Example: D-TA625

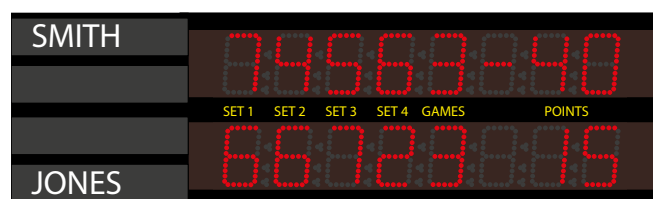

Example: D-TA815



Example: D-TA825-T415



The players' names can be placed on the boards using magnetic letters. Magnetic letters are available as an option.

TENNIS

LED Scoreboards



With LED Name Field

Tennis Scoreboard D-TA815-T415

Digit height: 150 mm
 Max. readability: up to 70 m
 Game display: 5 sets
 Time display: hours and minutes

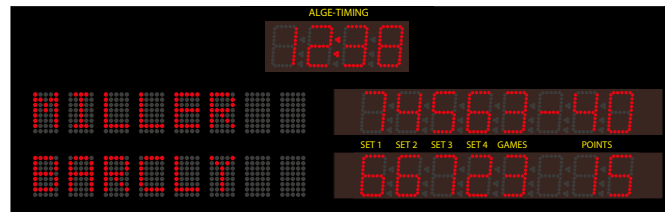

Tennis Scoreboard D-TA825-T415

Digit height: 250 mm
 Max. readability: up to 120 m
 Game display: 5 sets
 Time display: hours and minutes with 150 mm digits



Tennis Scoreboard D-TA815-2xT415-T

Digit height: 150 mm
 Max. readability: up to 70 m
 Game display: 5 sets
 Time display: hours and minutes
 Game time: hours and minutes

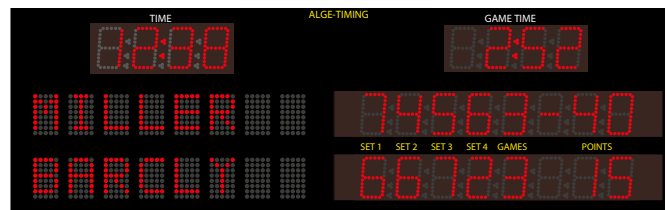

Tennis Scoreboard D-TA825-2xT415-T

Digit height: 250 mm
 Max. readability: up to 120 m
 Game display: 5 sets
 Time display: hours and minutes with 150 mm digit
 Game time: hours and minutes with 150 mm digits



Game, Set, Match - for the ALGE-TIMING LED Tennis Scoreboards

- red extra bright LEDs, which are easy to read even in direct sunlight
- adjustable brightness
- weatherproof aluminum housing for universal use in indoor and outdoor areas
- plexiglass protects LEDs from tennis balls
- controller with display and “intelligent” software
- (100 - 240 VAC) integrated in the scoreboard



MULTISPORT SCOREBOARDS



MULTISPORT SCOREBOARDS

General Information



The multisport scoreboards are designed for several ball sports, such as basketball, handball, volleyball, tennis, table tennis, hockey or football. But also competitions in judo, karate, taekwondo or wrestling can be accompanied by multisport scoreboards from ALGE-TIMING.

All scoreboards are connected by cable to the controller as standard, but are optionally supplied wirelessly, with radio. The multisport scoreboards can also be designed individually, for example, with text fields to display the team or player names.



Indoor and Outdoor Scoreboards

Most of the models are designed for use in halls but can be made with brighter LEDs for outdoor use.

Indicators (Digits)

The different models have different digit heights:

- D-S series: 15 cm digit height
- D-M series: 25 cm, 18 cm, 15 cm and 8 cm digit height
- D-L series: 30 cm, 25 cm, 18 cm and 15 cm digit height

Readability

Depending on the type of sport, the conditions that the scoreboard must meet are different. Please note, when selecting a scoreboard, that the digits are easy to read from everywhere inside the hall.

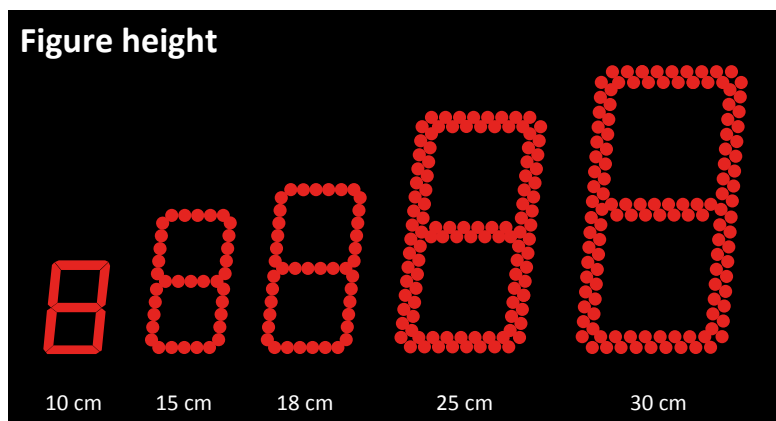

| Digit height | Maximum reading distance |
|--------------|--------------------------|
| 8 cm | up to 40 m |
| 15 cm | up to 75 m |
| 18 cm | up to 90 m |
| 25 cm | up to 125 m |
| 30 cm | up to 150 m |



MULTISPORT SCOREBOARDS

General Information

Cable or Radio

The standard ALGE-TIMING Multisport scoreboard systems comes with a cable connection. The included test cable must be replaced by the electrician who installs the scoreboard with a fix installed cable. The advantage lies, above all, in the safe and uncomplicated data transmission.

In addition, there is the possibility to control the system via radio. To do this, use the controller with integrated radio D-CKN-TXA and a scoreboard with a radio receiver D-RX. The wireless installation is mainly used in halls where cable connections are difficult. In the case of radio solutions, it must be noted that the scoreboard must be connected to the mains, despite a radio connection.

The operator of the scoreboard can move around in the sports arena, since the radio controller D-CKN-TXA has an integrated rechargeable battery.

Controller

ALGE-TIMING offers three different controllers. The standard controller D-CKN is always included in the scoreboard. For scoreboards which also contain text, a PC keyboard can be connected to the controller to enter the texts. The controller automatically saves the data in the case of a power failure. The time of day can be displayed on the scoreboard during times when it is not needed for a game.

Controller D-CKN

Standard controller for scoreboards controlled by cable

Controller D-CKN-TXA

Controller with integrated radio transmitter and battery for radio-controlled scoreboards and flexible use of the controller. The scoreboard requires a radio receiver D-RX.



controller D-CKN with input keyboard



controller D-CKN-TXA

Modules for Team Names

Alphanumeric modules with 3 to 9 characters make it possible, e.g. to display team names with 15 cm characters on the D-M models. Each red LED field of 7 x 5 pixels can display an alphanumeric character (option: 8 x 5 pixels).

On the D-L scoreboard series, team names can be displayed with a digit height of 25 cm, since the LED field for each character is 12 x 7 pixels.

To enter the team names, a PC keyboard is connected to the controller.

TNLP1V11-3

ESP

FRA

TNLP1V11-4

CUBA

MALI

TNLP1V11-5

ITALY

EGYPT

TNLP1V11-6

FRANCE

GREECE

TNLP1V11-7

HOLLAND

ROMANIA

TNLP1V11-8

PORTUGAL

BULGARIA

TNLP1V11-9

ARGENTINA

LITHUANIA

The picture shows different variants.

MULTISPORT SCOREBOARDS

General Information



| Model | Dimensions | Scoreboard | |
|------------|------------------------------|---|---------------------------------|
| TNP1V11-3 | 2 x Display size 26 x 15 cm | 2 x 3 Characters, 7 x 5 Dots, Character height 14 cm | for medium size scoreboards D-M |
| TNP1V11-4 | 2 x Display size 35 x 15 cm | 2 x 4 Characters, 7 x 5 Dots, Character height 14 cm | |
| TNP1V11-5 | 2 x Display size 44 x 15 cm | 2 x 5 Characters, 7 x 5 Dots, Character height 14 cm | |
| TNP1V11-6 | 2 x Display size 53 x 15 cm | 2 x 6 Characters, 7 x 5 Dots, Character height 14 cm | |
| TNP1V11-7 | 2 x Display size 66 x 15 cm | 2 x 7 Characters, 7 x 5 Dots, Character height 14 cm | |
| TNP1V11-8 | 2 x Display size 71 x 15 cm | 2 x 8 Characters, 7 x 5 Dots, Character height 14 cm | |
| TNP1V11-9 | 2 x Display size 80 x 15 cm | 2 x 9 Characters, 7 x 5 Dots, Character height 14 cm | |
| TNLP1V11-3 | 2 x Display size 35 x 25 cm | 2 x 2 Characters, 12 x 7 Dots, Character height 25 cm | for large size scoreboards D-L |
| TNLP1V11-4 | 2 x Display size 51 x 25 cm | 2 x 3 Characters, 12 x 7 Dots, Character height 25 cm | |
| TNLP1V11-5 | 2 x Display size 65 x 25 cm | 2 x 4 Characters, 12 x 7 Dots, Character height 25 cm | |
| TNLP1V11-6 | 2 x Display size 78 x 25 cm | 2 x 5 Characters, 12 x 7 Dots, Character height 25 cm | |
| TNLP1V11-7 | 2 x Display size 92 x 25 cm | 2 x 6 Characters, 12 x 7 Dots, Character height 25 cm | |
| TNLP1V11-8 | 2 x Display size 105 x 25 cm | 2 x 7 Characters, 12 x 7 Dots, Character height 25 cm | |
| TNLP1V11-9 | 2 x Display size 119 x 25 cm | 2 x 8 Characters, 12 x 7 Dots, Character height 25 cm | |

Modules for player names

Each expansion module can display 12 game names with 9 to 12 characters. In the D-M scoreboard series, the digit height is 7 cm and in the DL scoreboard series is 14 cm. The expansion modules can be combined with numeric digit fields for player numbers, personal fouls, points and goals.

| Model | Dimensions | Scoreboard | |
|-------|----------------------|--|---------------------------------|
| MPN9 | 2 Views 70 x 150 cm | 2 x 12 Player names, 9 Characters with 7 x 5 Dots, Character height 7 cm | for medium size scoreboards D-M |
| MPN10 | 2 Views 80 x 150 cm | 2 x 12 Player names, 10 Characters with 7 x 5 Dots, Character height 7 cm | |
| MPN11 | 2 Views 85 x 150 cm | 2 x 12 Player names, 11 Characters with 7 x 5 Dots, Character height 7 cm | |
| MPN12 | 2 Views 90 x 150 cm | 2 x 12 Player names, 12 Characters with 7 x 5 Dots, Character height 7 cm | |
| LPN9 | 2 Views 100 x 250 cm | 2 x 12 Player names, 9 Characters with 7 x 5 Dots, Character height 14 cm | for large size scoreboards D-L |
| LPN10 | 2 Views 105 x 250 cm | 2 x 12 Player names, 10 Characters with 7 x 5 Dots, Character height 14 cm | |
| LPN11 | 2 Views 115 x 250 cm | 2 x 12 Player names, 11 Characters with 7 x 5 Dots, Character height 14 cm | |
| LPN12 | 2 Views 120 x 250 cm | 2 x 12 Player names, 12 Characters with 7 x 5 Dots, Character height 14 cm | |



NPN9

NPN10

NPN11

NPN12

LPN9

LPN10

LPN11

LPN12



MULTISPORT SCOREBOARDS

Customized Scoreboards

Customer-specific scoreboards can be individually designed. Many additional features are possible like team names, player name, time of day or temperature. It can be connected via cable or radio to the controller. Special solutions like scoreboards built in a cube and/or integrated video wall(s) are possible.

Example: Customized scoreboard with integrated video wall for basketball



MULTISPORT SCOREBOARDS

Tabletop Scoreboards



Tabletop scoreboards are easy to transport, thanks to their size, and setting them up on a table near the field is simple. The operator of the scoreboard has a separate display on the back and a simple control panel with four buttons. The tabletop scoreboard is ideal for schools and other small ball sport events.



Facts of the Tabletop Scoreboard

- small, universal and easily transportable
- designed for use in halls
- red digits (LED) with white captions
- game time: 99:59 minutes, counted down or up; last minute in 1/10 seconds
- time of day (integrated realtime chip) can be displayed at "Playtime" position
- scores: 0 to 99 for both teams
- Operator can see the scoreboard data on the back side of the scoreboard.
- complete system with controller and four push buttons
- integrated horn
- power supply: 110/220 VAC - 50/60 Hz
- Models are available with 57 mm, 80 mm, 100 mm and 150 mm digit height.
- sturdy aluminum housing with plexiglass on the front



| Model | Dimensions (LxHxW) | Digit height | Visibility | Purpose of use |
|------------|---------------------|--------------|------------|----------------|
| D-TT57-H | 550 x 150 x 70 mm | 57 mm | 25 m | Indoor |
| D-TT80-H | 750 x 180 x 70 mm | 80 mm | 40 m | Indoor |
| D-TT100-H | 1,000 x 230 x 70 mm | 100 mm | 50 m | Indoor |
| D-TT150-H | 1,250 x 280 x 70 mm | 150 mm | 75 m | Indoor |
| D-TT80-OH | 750 x 180 x 70 mm | 80 mm | 40 m | Outdoor/Indoor |
| D-TT150-OH | 1,250 x 280 x 70 mm | 150 mm | 75 m | Outdoor/Indoor |

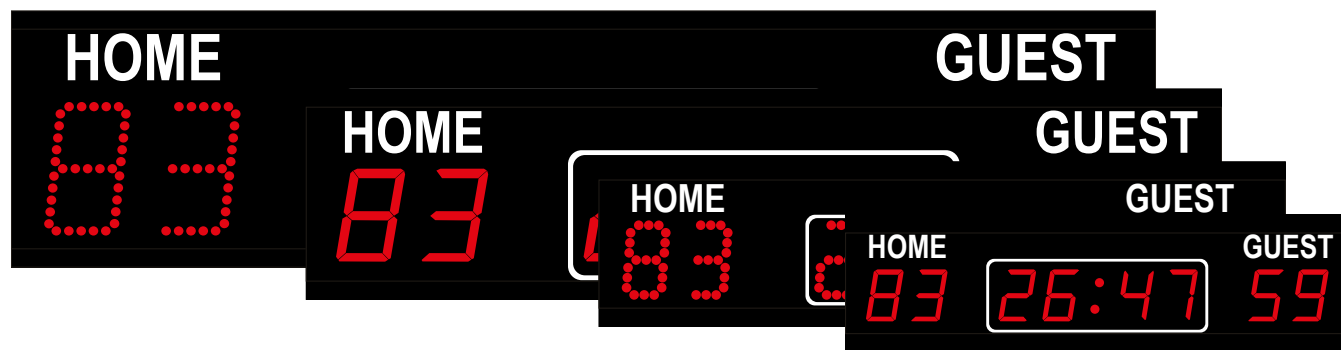

D-TT-150H

D-TT-100H

D-TT-80H

D-TT-57H



MULTISPORT SCOREBOARDS

D-S1S

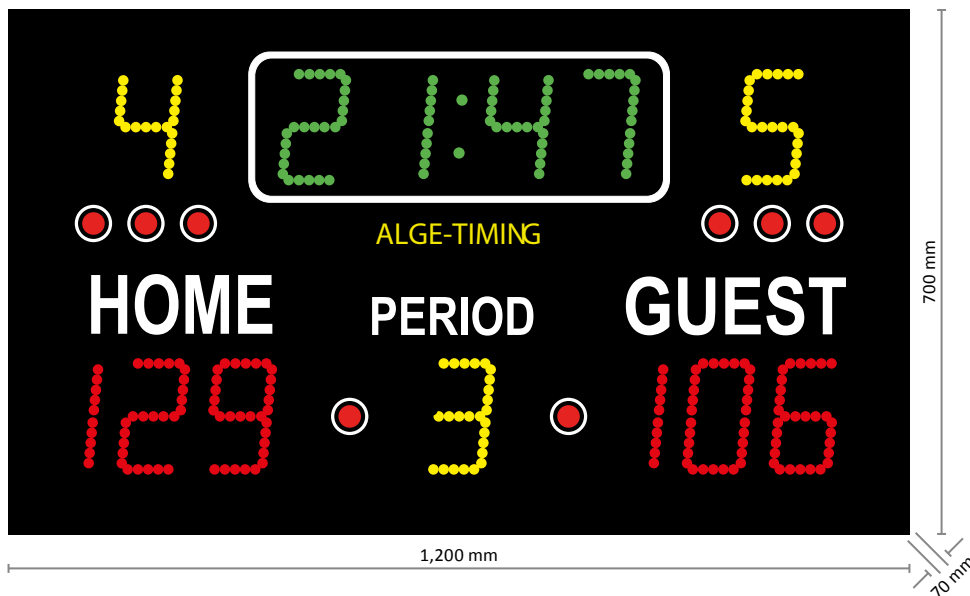

Facts about the D-S1S Scoreboard

- small, universal scoreboard for indoor use
- digits (LED) in three colors: red, green and yellow, white captions
- running time in minutes and seconds (up/down, green 15 cm digits); during last minute display in seconds and 1/10
- daytime can be displayed on the game time field
- time can be displayed in the game time field
- score: 0 to 199 for each team (red 15 cm digits)
- period: 0 to 9 (yellow 15 cm digit)
- team fouls: 0 to 9 for each team (yellow 15 cm digits)
- LED cluster: red LED cluster (2 cm diameter) for time-out, bonus, serve and/or ball possession
- horn (interval time adjustable from 0 to 9 seconds)
- power supply: 110/220 VAC - 50/60 Hz
- dimensions: 1'200 x 700 x 70 mm
- weight: approx. 15 kg

Type of Sport

basketball, handball, volleyball, football, tennis, table tennis, etc.

Controller

D-CKN (standard) or D-CKN-TXA (option)

MULTISPORT SCOREBOARDS

D-S3S

0:00:00

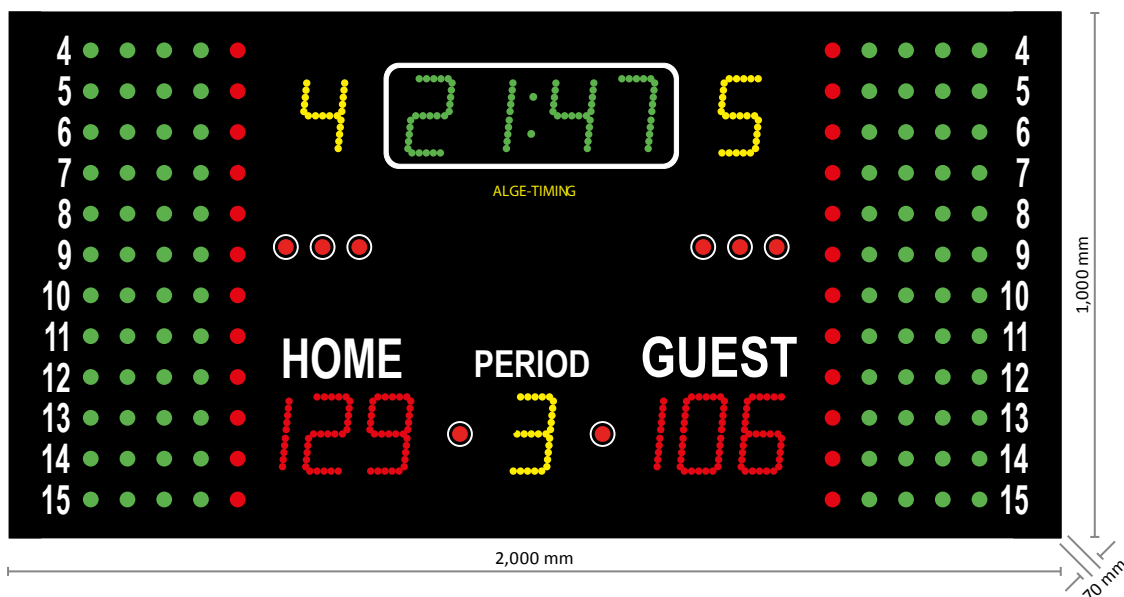

Facts about the D-S3S Scoreboard

- small, universal scoreboard for halls
- digits (LED) in three colors: red, green and yellow, white captions
- running time in minutes and seconds (up/down, green 25 cm digits); during last minute display in seconds and 1/10
- daytime can be displayed on the game time field
- time can be displayed in the game time field
- score: 0 to 199 for each team (red 15 cm digits)
- period: 0 to 9 (yellow 15 cm digit)
- team fouls: 0 to 9 for each team (yellow 15 cm digits)
- LED cluster: red LED cluster (2 cm diameter) for time-out, bonus, serve and/or ball possession
- personal fouls: 12 players per team, per player 4 green and 1 red LED cluster (each 2 cm diameter)
- horn (interval time adjustable from 0 to 9 seconds)
- power supply: 110/220 VAC - 50/60 Hz
- dimensions: 2,000 x 1,000 x 70 mm
- weight: approx. 40 kg

Type of Sport

basketball, handball, volleyball, football, tennis, table tennis, etc.

Controller

D-CKN (standard) or D-CKN-TXA (option)



MULTISPORT SCOREBOARDS

D-S5S

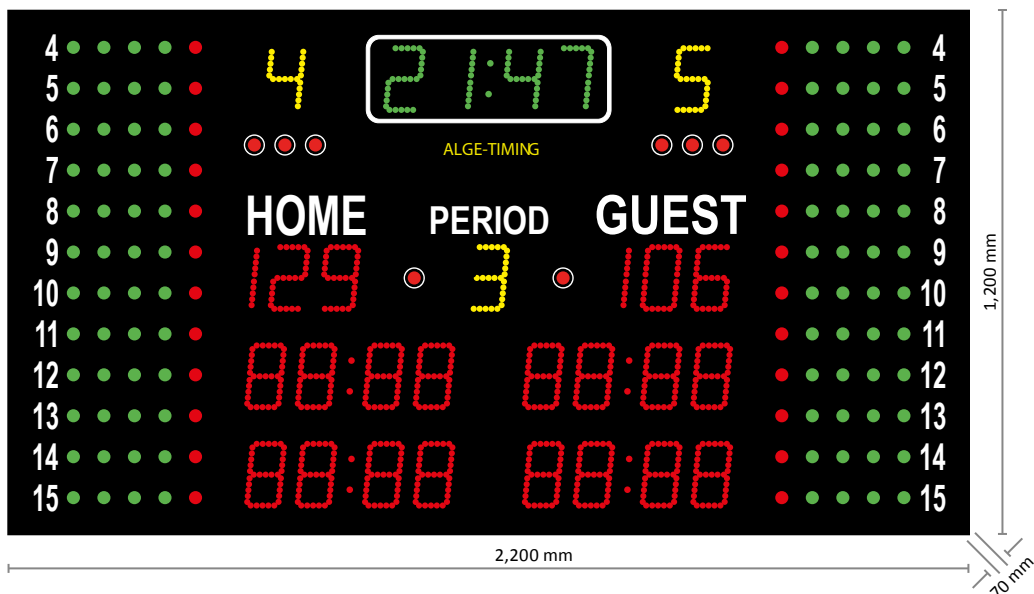

Facts about the D-S5S Scoreboard

- small, universal scoreboard for halls
- digits (LED) in three colors: red, green and yellow, white captions
- running time in minutes and seconds (up/down, green 15 cm digits); during last minute display in seconds and 1/10
- daytime can be displayed on the game time field
- time can be displayed in the game time field
- score: 0 to 199 for each team (red 15 cm digits)
- period: 0 to 9 (yellow 15 cm digit)
- team fouls: 0 to 9 for each team (yellow 15 cm digits)
- LED cluster: red LED cluster (2 cm diameter) for time-out, bonus, serve and/or ball possession
- personal fouls: 12 players per team, per player 4 green and 1 red LED cluster (each 2 cm diameter)
- penalties: two penalties per team, per penalty four red digits (red 15 cm digits)
- horn (interval time adjustable from 0 to 9 seconds)
- power supply: 110/220 VAC - 50/60 Hz
- dimensions: 2,200 x 1,200 x 70 mm
- weight: approx. 50 kg

Type of Sport

basketball, handball, volleyball, football, tennis, table tennis, etc.

Controller

D-CKN (standard) or D-CKN-TXA (option)

MULTISPORT SCOREBOARDS

D-M1S

0:00:00

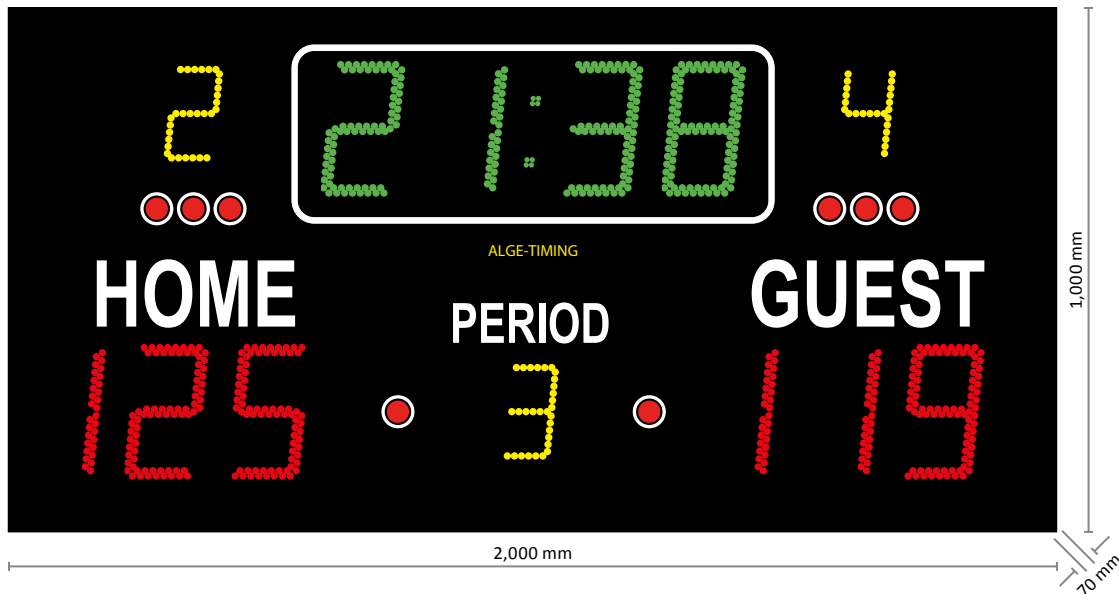

Facts about the D-M1S Scoreboard

- digits (LED) in three colors: red, green and yellow, white captions
- running time in minutes and seconds (up/down, green 25 cm digits); during last minute display in seconds and 1/10
- daytime can be displayed in the game time field
- time can be displayed in the game time field
- scores: 0 to 199 for each team (red 25 cm digits)
- period: 0 to 9 (yellow 18 cm digit)
- team fouls: 0 to 9 for each team (yellow 18 cm digits)
- LED cluster: red LED cluster (2 cm diameter) for time-out, bonus, serve and/or ball possession
- horn
- power supply: 110/220 VAC - 50/60 Hz
- dimensions: 2,000 x 1,000 x 70 mm
- weight: approx. 40 kg

Type of Sport

basketball, handball, volleyball, football, tennis, table tennis, etc.

Controller

D-CKN (standard) or D-CKN-TXA (option)



MULTISPORT SCOREBOARDS

D-M3S

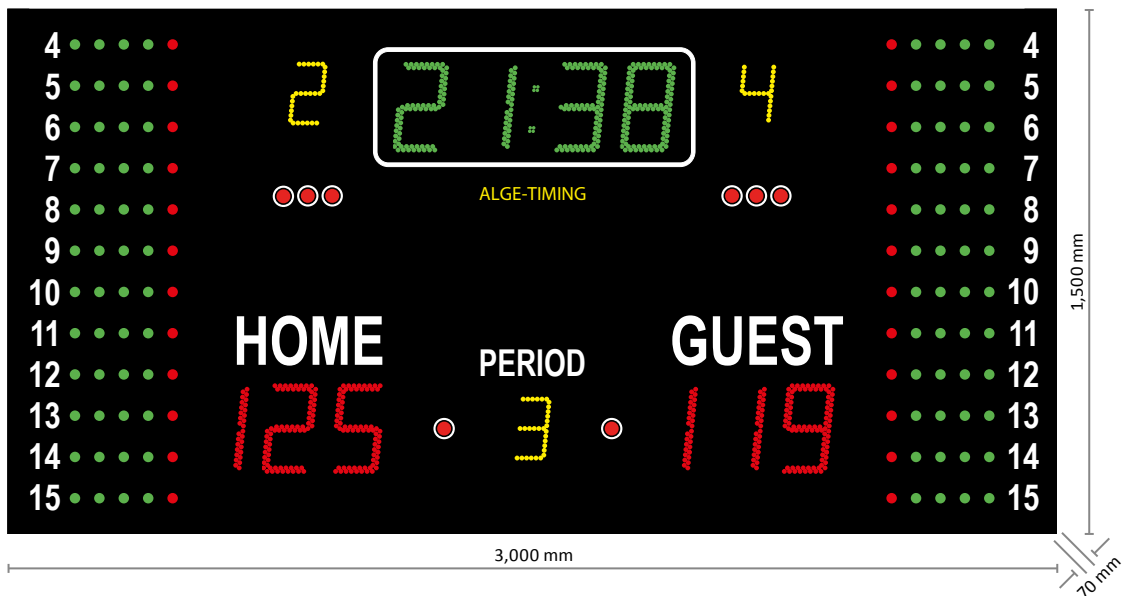

Facts about the D-M3S Scoreboard

- digits (LED) in three colors: red, green and yellow, white captions
- running time in minutes and seconds (up/down, green 25 cm digits); during last minute display in seconds and 1/10
- daytime can be displayed on the game time field
- time can be displayed in the game time field
- scores: 0 to 199 for each team (red 25 cm digits)
- period: 0 to 9 (yellow 18 cm digit)
- team fouls: 0 to 9 for each team (yellow 18 cm digit)
- LED cluster: red LED cluster (2 cm diameter) for time-out, bonus, serve and/or ball possession
- personal fouls: 12 players per team, per player 4 green and 1 red LED cluster (each 2 cm diameter)
- horn
- power supply: 110/220 VAC - 50/60 Hz
- dimensions: 3,000 x 1,500 x 70 mm
- weight: approx. 90 kg

Type of Sport

basketball, handball, volleyball, football, tennis, table tennis, etc.

Controller

D-CKN (standard) or D-CKN-TXA (option)

MULTISPORT SCOREBOARDS

D-M3SP

0:00:00

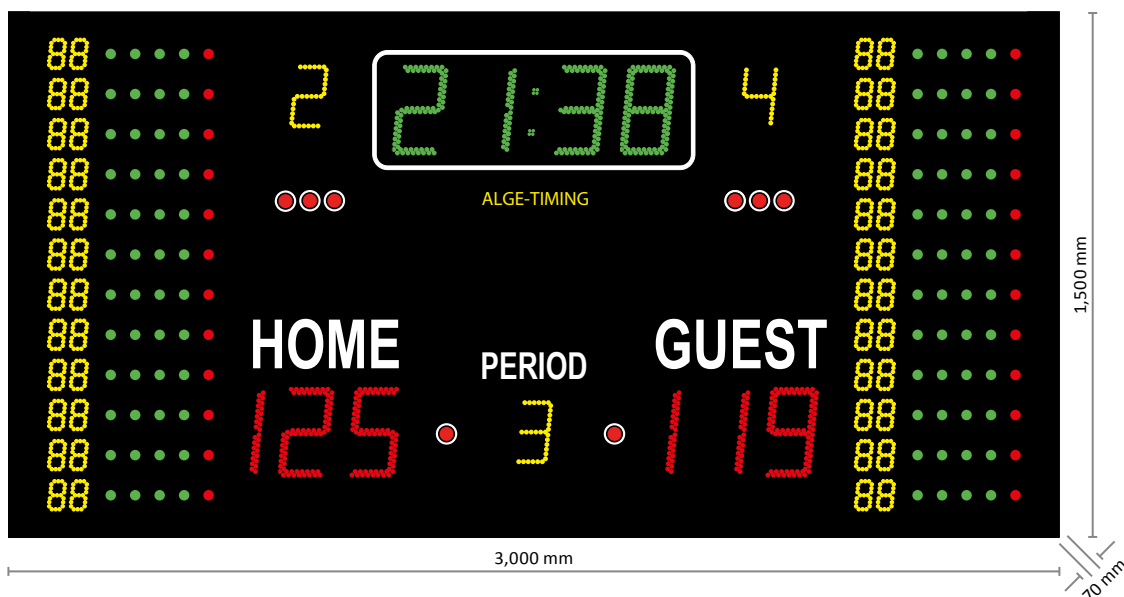

Facts about the D-M3SP Scoreboard

- digits (LED) in three colors: red, green and yellow, white captions
- running time in minutes and seconds (up/down, green 25 cm digits); during last minute display in seconds and 1/10
- daytime can be displayed on the game time field
- time can be displayed in the game time field
- scores: 0 to 199 for each team (red 25 cm digits)
- period: 0 to 9 (yellow 18 cm digit)
- team fouls: 0 to 9 for each team (yellow 18 cm digits)
- personal fouls: 12 players per team with adjustable number of players (0 - 99; yellow 8 cm digits), per player 4 green and 1 red LED cluster (2 cm diameter each)
- LED cluster: red LED cluster (2 cm diameter) for time-out, bonus, serve and/or ball possession
- horn
- power supply: 110/220 VAC - 50/60 Hz
- dimensions: 3,000 x 1,500 x 70 mm
- weight: approx. 90 kg

Type of Sport

basketball, handball, volleyball, football, tennis, table tennis, etc.

Controller

D-CKN (standard) or D-CKN-TXA (option)



MULTISPORT SCOREBOARDS

D-M4SH2

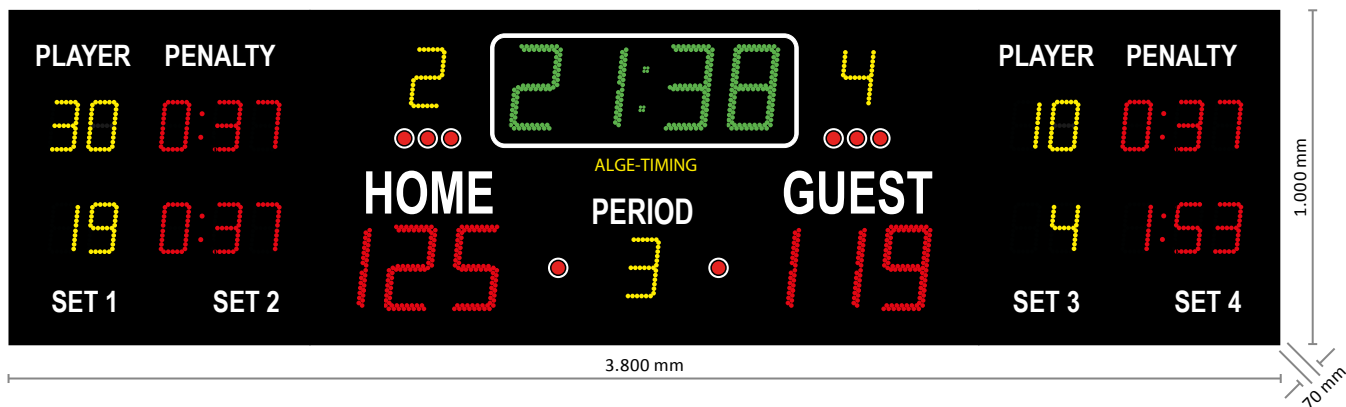

Facts about the D-M4SH2 Scoreboard

- three modules: middle part 2,000 x 1,000 mm, sides 2 x 900 x 1,000 mm Digits (LED) in three colors: red, green and yellow, white captions
- running time in minutes and seconds (up/down, green 25 cm digits); during last minute display in seconds and 1/10
- daytime can be displayed on the game time field
- time can be displayed on the game time field
- score: 0 to 199 for each team (red 25 cm digits)
- period: 0 to 9 (yellow 18 cm digit)
- team fouls: 0 to 9 for each team (yellow 18 cm digits)
- LED cluster: red LED cluster (2 cm diameter) for time-out, bonus, serve and/or ball possession
- penalties: 2 x 0 to 9:59 per team (red 15 cm digits)
- player number for penalties: 2 x 0 to 99 per team (yellow 15 cm digits)
- horn
- power supply: 110/220 VAC - 50/60 Hz
- dimensions: 3,800 x 1,000 x 70 mm
- weight: approx. 75 kg

Basketball

- team fouls: 0 to 9 (yellow 18 cm digits)
- player ID: 0 to 99 (yellow 15 cm digits)
- personal fouls: 0 to 99 (red 15 cm digits)

Volleyball, Table Tennis and Tennis

- score per set: 2 x 0 to 99 (15 cm digits)

Handball and Hockey

- player ID: 0 to 99 (yellow 15 cm digits)
- player foul: 0 to 9:59 (red 15 cm digits)

Type of Sport

basketball, handball, volleyball, football, tennis, table tennis, etc.

Controller

D-CKN (standard) or D-CKN-TXA (option)

MULTISPORT SCOREBOARDS

D-M4SV2

0:00:00

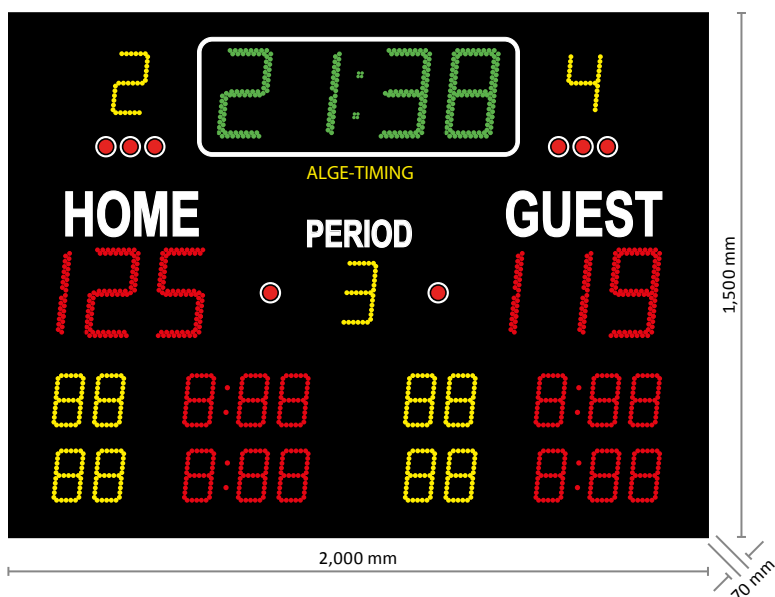

Facts about the D-M4SV2 Scoreboard

- digits (LED) in three colors: red, green and yellow, white captions
- running time in minutes and seconds (up/down, green 25 cm digits); during last minute display in seconds and 1/10
- daytime can be displayed on the game time field
- time can be displayed in the game time field
- score: 0 to 199 for each team (red 25 cm digits)
- period: 0 to 9 (yellow 18 cm digit)
- team fouls: 0 to 9 for each team (yellow 18 cm digits)
- LED cluster: red LED cluster (2 cm diameter) for time-out, bonus, serve and/or ball possession
- penalties: 2 x 0 to 9:59 per team (red 15 cm digits)
- player number for penalties: 2 x 0 to 99 per team (yellow 15 cm digits)
- horn
- power supply: 110/220 VAC - 50/60 Hz
- dimensions: 2,000 x 1,500 x 70 mm
- weight: approx. 60 kg

Basketball

- team fouls: 0 to 9 (yellow 18 cm digits)
- player ID: 0 to 99 (yellow 15 cm digits)
- personal fouls: 0 to 99 (red 15 cm digits)

Volleyball, Table Tennis and Tennis

- score per set: 2 x 0 to 99 (15 cm digits)

Handball and Hockey

- player ID: 0 to 99 (yellow 15 cm digits)
- player foul: 0 to 9:59 (red 15 cm digits)

Type of Sport

basketball, handball, volleyball, football, tennis, table tennis, etc.

Controller

D-CKN (standard) or D-CKN-TXA (option)



MULTISPORT SCOREBOARDS

D-M5S

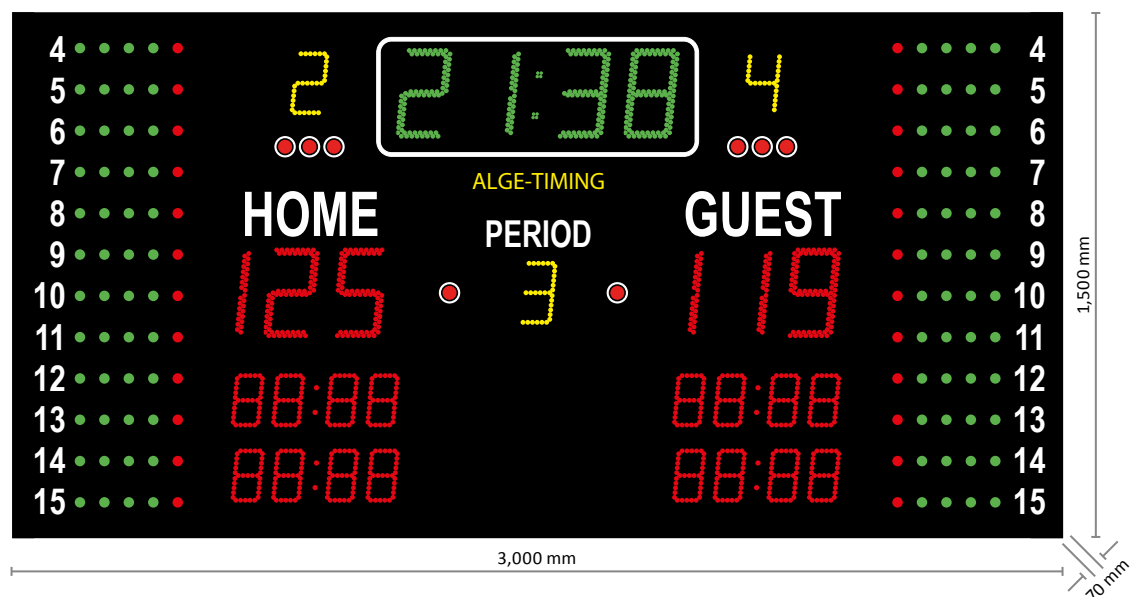

Facts about the D-M5S Scoreboard

- digits (LED) in three colors: red, green and yellow, white captions
- running time in minutes and seconds (up/down, green 25 cm digits); during last minute display in seconds and 1/10
- daytime can be displayed on the game time field
- time can be displayed in the game time field
- score: 0 to 199 for each team (red 25 cm digits)
- period: 0 to 9 (yellow 18 cm digit)
- team fouls: 0 to 9 for each team (yellow 18 cm digits)
- LED cluster: red LED cluster (2 cm diameter) for time-out, bonus, serve and/or ball possession
- penalties: two penalties per team, per penalty four red digits (red 15 cm digits)
- personal fouls: 12 players per team, per player 4 green and 1 red LED cluster (each 2 cm diameter)
- horn
- power supply: 110/220 VAC - 50/60 Hz
- dimensions: 3,000 x 1,500 x 70 mm
- weight: approx. 90 kg

Type of Sport

basketball, handball, volleyball, football, tennis, table tennis, etc.

Controller

D-CKN (standard) or D-CKN-TXA (option)

MULTISPORT SCOREBOARDS

D-M6S

0:00:00

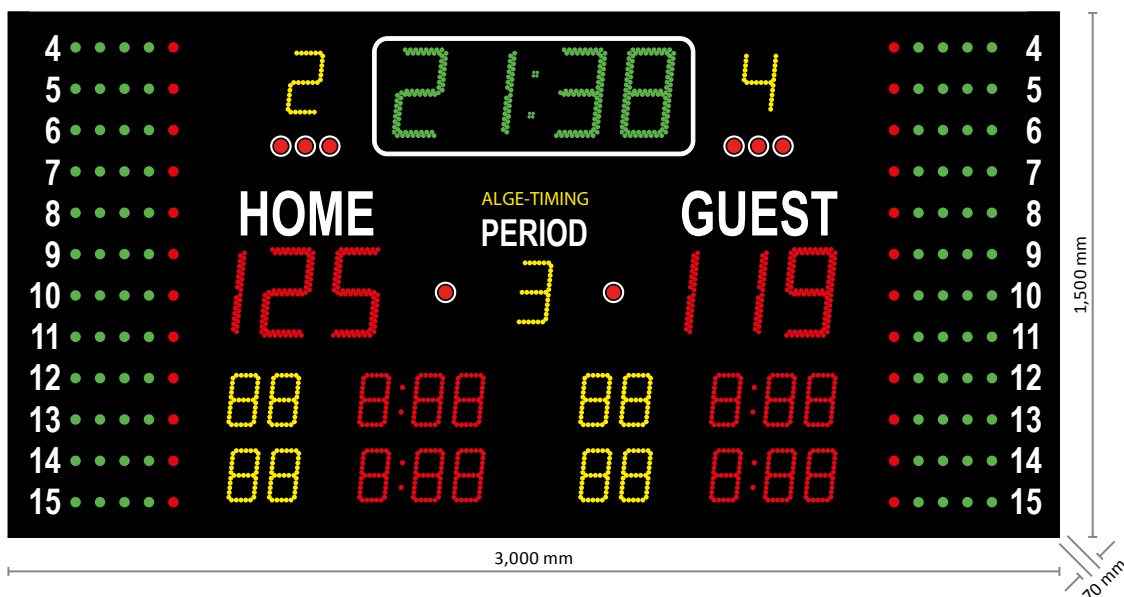

Facts about the D-M6S Scoreboard

- digits (LED) in three colors: red, green and yellow, white captions
- running time in minutes and seconds (up/down, green 25 cm digits); during last minute display in seconds and 1/10
- daytime can be displayed on the game time field
- time can be displayed in the game time field
- score: 0 to 199 for each team (red 25 cm digits)
- period: 0 to 9 (yellow 18 cm digit)
- team fouls: 0 to 9 for each team (yellow 18 cm digits)
- LED cluster: red LED cluster (2 cm diameter) for time-out, bonus, serve and/or ball possession
- penalties: 2 x 0 to 9:59 per team (red 15 cm digits)
- player number for penalties: 2 x 0 to 99 per team (yellow 15 cm digits)
- personal fouls: 12 players per team, per player 4 green and 1 red LED cluster (each 2 cm diameter)
- horn
- power supply: 110/220 VAC - 50/60 Hz
- dimensions: 3,000 x 1,500 x 70 mm
- weight: approx. 90 kg

Basketball

- team fouls: 0 to 9 (yellow 18 cm digits)
- player ID: 0 to 99 (yellow 15 cm digits)
- personal fouls: 0 to 99 (red 15 cm digits)

Volleyball, Table Tennis and Tennis

- score per set: 2 x 0 to 99 (15 cm digits)

Handball and Hockey

- player ID: 0 to 99 (yellow 15 cm digits)
- player foul: 0 to 9:59 (red 15 cm digits)

Type of Sport

basketball, handball, volleyball, football, tennis, table tennis, etc.

Controller

D-CKN (standard) or D-CKN-TXA (option)



MULTISPORT SCOREBOARDS

D-M6SP

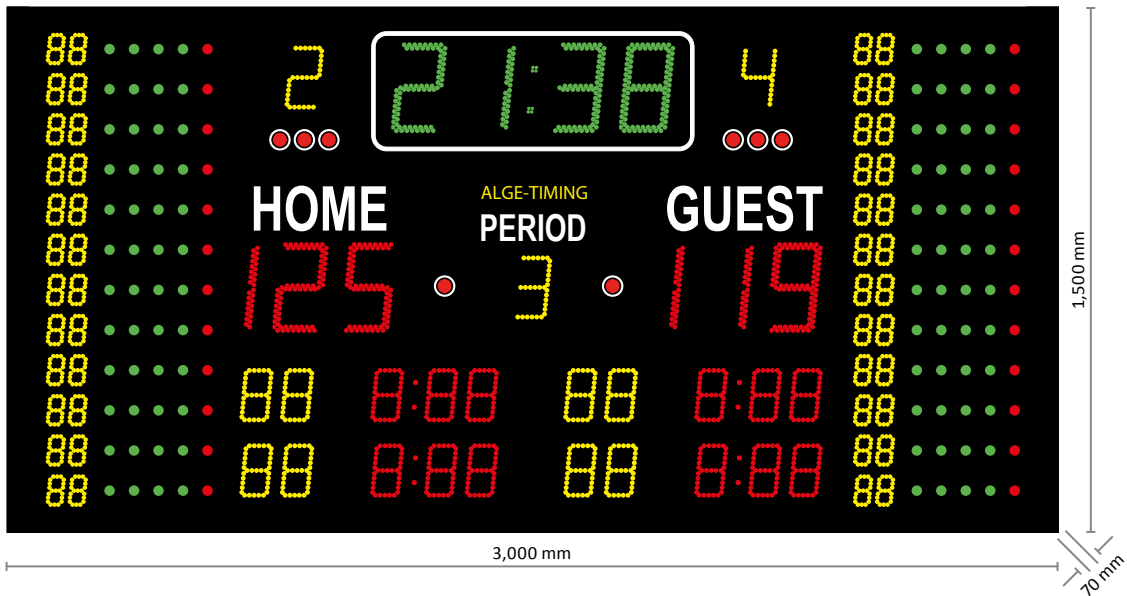

Facts about the D-M6SP Scoreboard

- digits (LED) in three colors: red, green and yellow, white captions
- running time in minutes and seconds (up/down, green 25 cm digits); during last minute display in seconds and 1/10
- daytime can be displayed on the game time field
- time can be displayed in the game time field
- score: 0 to 199 for each team (red 25 cm digits)
- period: 0 to 9 (yellow 18 cm digit)
- team fouls: 0 to 9 for each team (yellow 18 cm digits)
- LED cluster: red LED cluster (2 cm diameter) for time-out, bonus, serve and/or ball possession
- penalties: 2 x 0 to 9:59 per team (red 15 cm digits)
- player number for penalties: 2 x 0 to 99 per team (yellow 15 cm digits)
- personal player data: 12 players per team, with adjustable number of players (0 - 99; yellow 8 cm digits), per player 4 green and 1 red LED cluster (2 cm diameter each)
- horn
- power supply: 110/220 VAC - 50/60 Hz
- dimensions: 3,000 x 1,500 x 70 mm
- weight: approx. 90 kg

Basketball

- team fouls: 0 to 9 (yellow 18 cm digits)
- player ID: 0 to 99 (yellow 15 cm digits)
- personal fouls: 0 to 99 (red 15 cm digits)

Volleyball, Table Tennis and Tennis

- score per set: 2 x 0 to 99 (15 cm digits)

Handball and Hockey

- player ID: 0 to 99 (yellow 15 cm digits)
- player foul: 0 to 9:59 (red 15 cm digits)

Type of Sport

basketball, handball, volleyball, football, tennis, table tennis, etc.

Controller

D-CKN (standard) or D-CKN-TXA (option)

MULTISPORT SCOREBOARDS

D-M6SPP

0:00:00

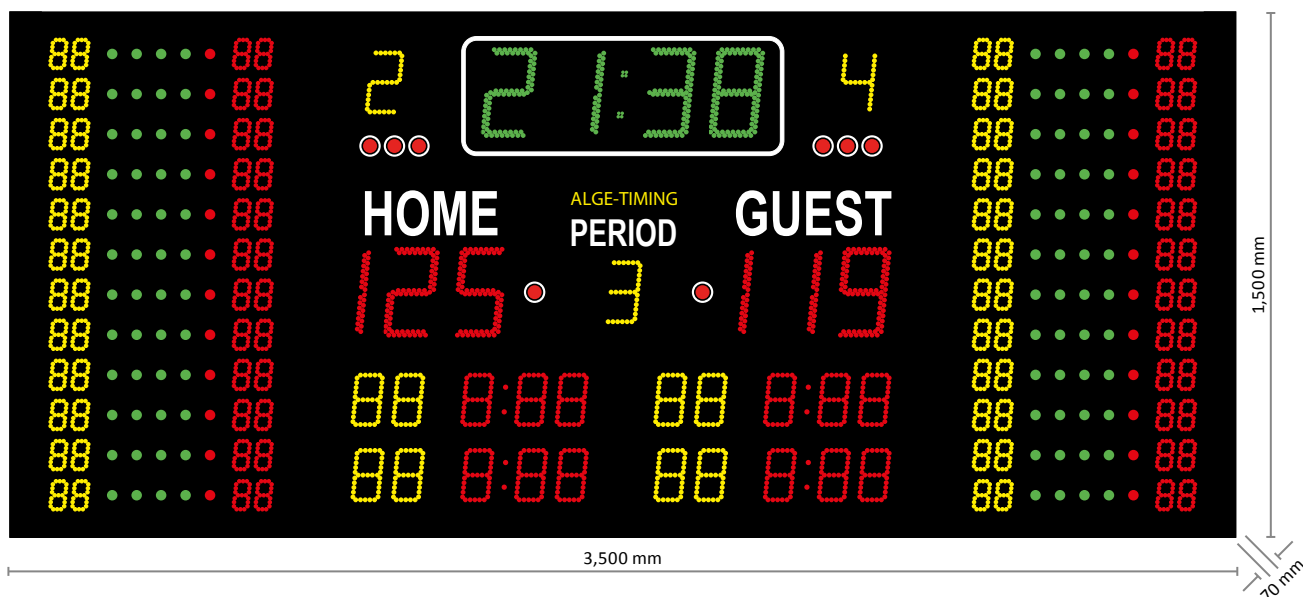

Facts about the D-M6SPP Scoreboard

- digits (LED) in three colors: red, green and yellow, white captions
- running time in minutes and seconds (up/down, green 25 cm digits); during last minute display in seconds and 1/10
- daytime can be displayed on the game time field
- time can be displayed in the game time field
- score: 0 to 199 for each team (red 25 cm digits)
- period: 0 to 9 (yellow 18 cm digit)
- team fouls: 0 to 9 for each team (yellow 18 cm digits)
- LED cluster: red LED cluster (2 cm diameter) for time-out, bonus, serve and/or ball possession
- penalties: 2 x 0 to 9:59 per team (red 15 cm digits)
- player number for penalties: 2 x 0 to 99 per team (yellow 15 cm digits)
- personal player data: 12 players per team, with adjustable number of players (0 - 99; yellow 8 cm digits), per player 4 green and 1 red LED cluster (2 cm diameter each)
- horn
- power supply: 110/220 VAC - 50/60 Hz
- dimensions: 3,500 x 1,500 x 70 mm
- weight: approx. 100 kg

Basketball

- team fouls: 0 to 9 (yellow 18 cm digits)
- player ID: 0 to 99 (yellow 15 cm digits)
- personal fouls: 0 to 99 (red 15 cm digits)

Volleyball, Table Tennis and Tennis

- score per set: 2 x 0 to 99 (15 cm digits)

Handball and Hockey

- player ID: 0 to 99 (yellow 15 cm digits)
- player foul: 0 to 9:59 (red 15 cm digits)

Type of Sport

basketball, handball, volleyball, football, tennis, table tennis, etc.

Controller

D-CKN (standard) or D-CKN-TXA (option)



MULTISPORT SCOREBOARDS

D-M6SPFP

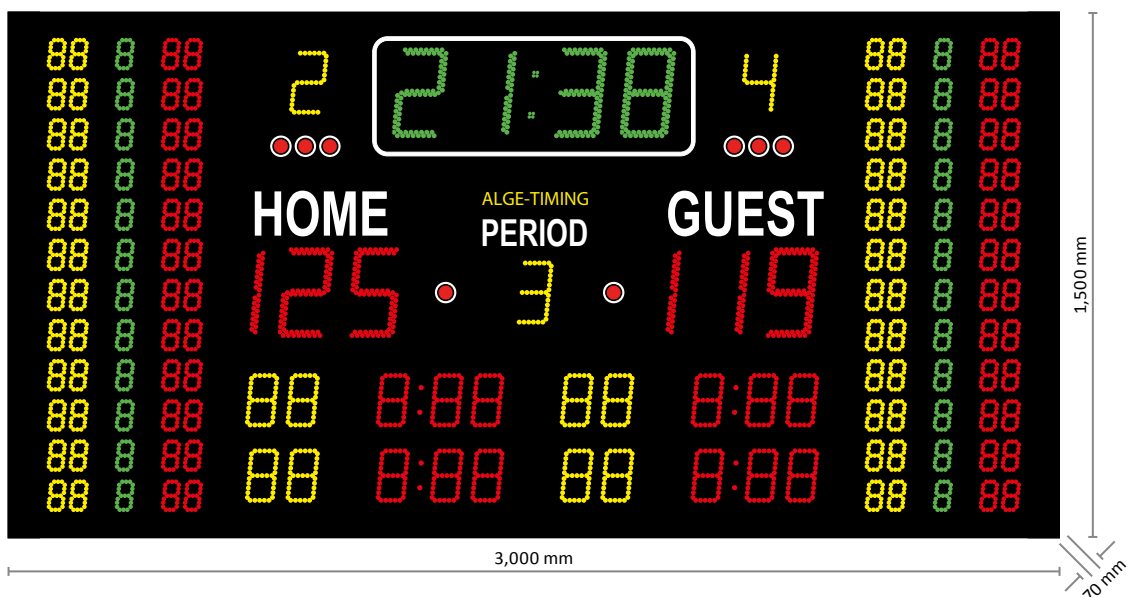

Facts about the D-M6SPFP Scoreboard

- digits (LED) in three colors: red, green and yellow, white captions
- running time in minutes and seconds (up/down, green 25 cm digits); during last minute display in seconds and 1/10
- daytime can be displayed on the game time field
- time can be displayed in the game time field
- scores: 0 to 199 for each team (red 25 cm digits)
- period: 0 to 9 (yellow 18 cm digit)
- team fouls: 0 to 9 for each team (yellow 18 cm digits)
- LED cluster: red LED cluster (2 cm diameter) for time-out, bonus, serve and/or ball possession
- penalties: 2 x 0 to 9:59 per team (red 15 cm digits)
- player number for penalties: 2 x 0 to 99 per team (yellow 15 cm digits)
- personal player data: 12 players per team with adjustable number of players (0 - 99, yellow 8 cm digits), personal fouls (0 - 9, green 8 cm digits) and points (0 - 99, red 8 cm digits)
- horn
- power supply: 110/220 VAC - 50/60 Hz
- dimensions: 3,000 x 1,500 x 70 mm
- weight: approx. 90 kg

Basketball

- team fouls: 0 to 9 (yellow 18 cm digits)
- player ID: 0 to 99 (yellow 15 cm digits)
- personal fouls: 0 to 99 (red 15 cm digits)

Volleyball, Table Tennis and Tennis

- score per set: 2 x 0 to 99 (15 cm digits)

Handball and Hockey

- player ID: 0 to 99 (yellow 15 cm digits)
- player foul: 0 to 9:59 (red 15 cm digits)

Type of Sport

basketball, handball, volleyball, football, tennis, table tennis, etc.

Controller

D-CKN (standard) or D-CKN-TXA (option)

MULTISPORT SCOREBOARDS

D-M6SBHV

00:00:00

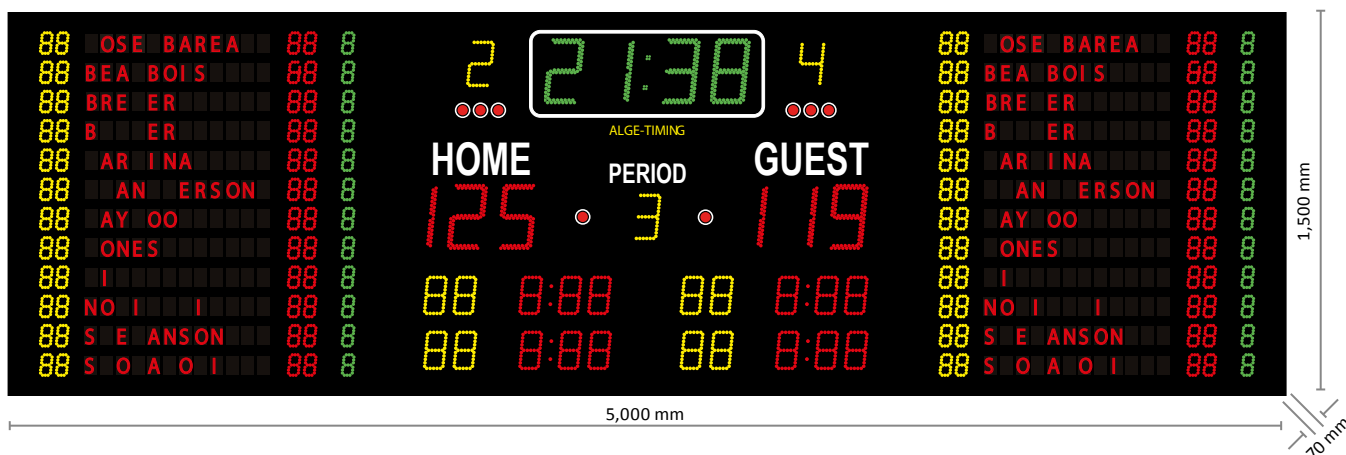

Facts about the D-M6SBHV Scoreboard

- three modules: middle section 2,000 x 1,500 mm, sides 2 x 1,500 x 1,500 mm
- digits (LED) in three colors: red, green and yellow, white captions
- running time in minutes and seconds (up/down, green 25 cm digits); during last minute display in seconds and 1/10
- daytime can be displayed on the game time field
- time can be displayed in the game time field
- score: 0 to 199 for each team (red 25 cm digits)
- period: 0 to 9 (yellow 18 cm digit)
- team fouls: 0 to 9 for each team (yellow 18 cm digits)
- LED cluster: red LED cluster (2 cm diameter) for time-out, bonus, serve and/or ball possession
- penalties: 2 x 0 to 9:59 per team (red 15 cm digits)
- player number for penalties: 2 x 0 to 99 per team (yellow 15 cm digits)
- personal player data: 12 players per team with adjustable
 - player number (0 - 99; yellow 8 cm digits)
 - player names (12 alphanumeric characters, red 8 cm digits)
 - points (0 - 99, red 8 cm digits)
 - personal fouls (0 - 9, green 8 cm digits)
- horn
- power supply: 110/220 VAC - 50/60 Hz
- dimensions: 5,000 x 1,500 x 70 mm
- weight: approx. 150 kg

Basketball

- team fouls: 0 to 9 (yellow 18 cm digits)
- player ID: 0 to 99 (yellow 15 cm digits)
- personal fouls: 0 to 99 (red 15 cm digits)

Volleyball, Table Tennis and Tennis

- score per set: 2 x 0 to 99 (15 cm digits)

Handball and Hockey

- player ID: 0 to 99 (yellow 15 cm digits)
- player foul: 0 to 9:59 (red 15 cm digits)

Type of Sport

basketball, handball, volleyball, football, tennis, table tennis, etc.

Controller

D-CKN (standard) or D-CKN-TXA (option)



MULTISPORT SCOREBOARDS

D-L1S

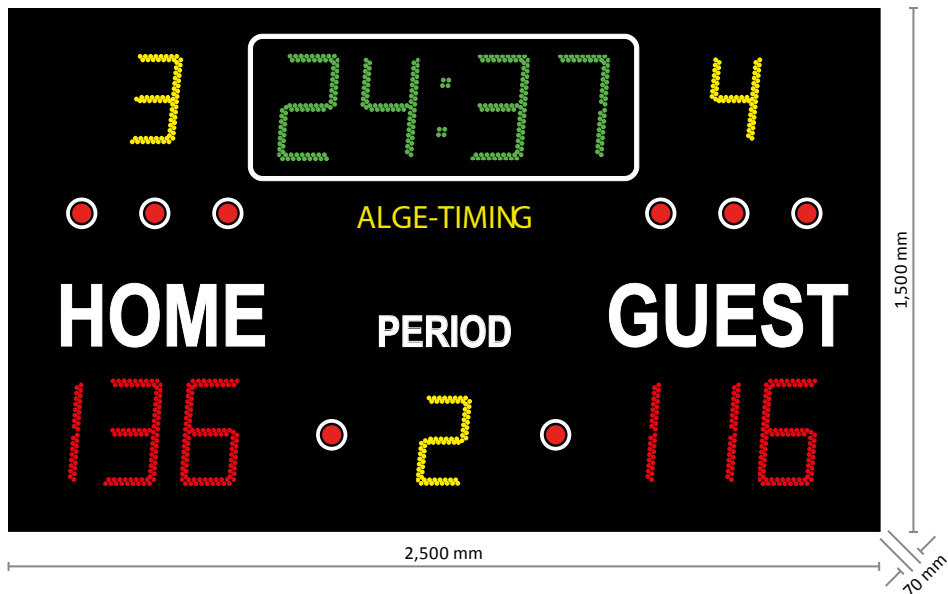

Facts about the D-L1S Scoreboard

- digits (LED) in three colors: red, green and yellow, white captions
- running time in minutes and seconds (up/down, green 30 cm digits); during last minute display in seconds and 1/10
- daytime can be displayed on the game time field
- time can be displayed in the game time field
- scores: 0 to 199 for each team (red 30 cm digits)
- period: 0 to 9 (yellow 25 cm digit)
- team fouls: 0 to 9 for each team (yellow 25 cm digits)
- LED cluster: red LED cluster (4 cm diameter) for time-out, bonus, serve and/or ball possession
- horn
- power supply: 110/220 VAC - 50/60 Hz
- dimensions: 2,500 x 1,500 x 70 mm
- weight: approx. 70 kg

Type of Sport

basketball, handball, volleyball, football, tennis, table tennis, etc.

Controller

D-CKN (standard) or D-CKN-TXA (option)

MULTISPORT SCOREBOARDS

D-L3S

0:00:00

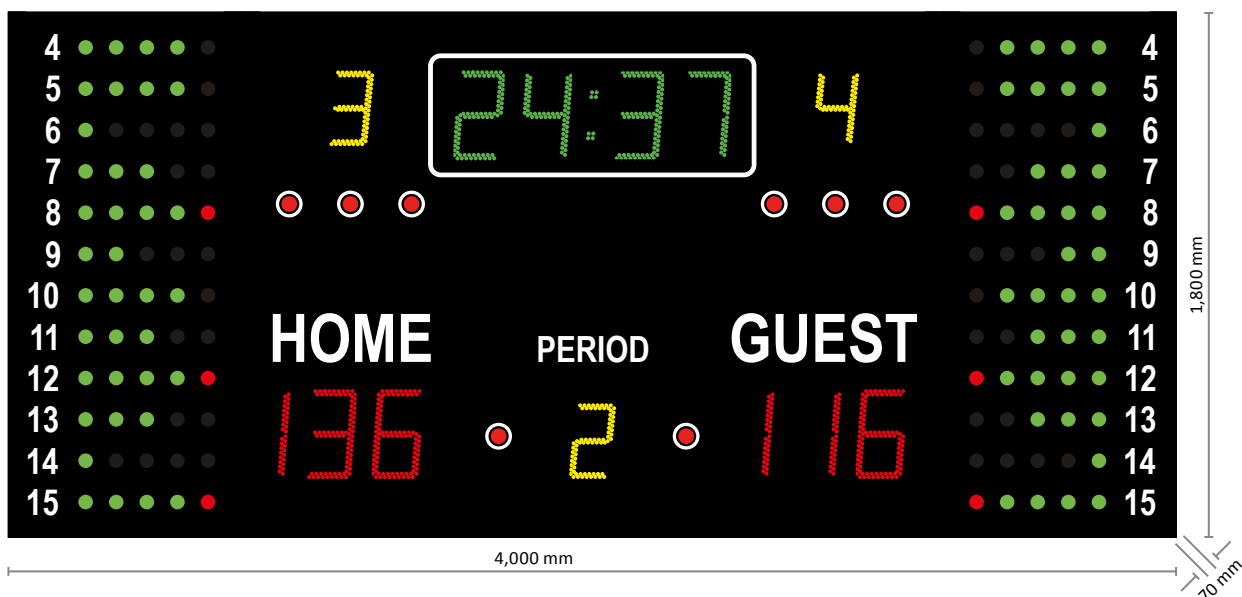

Facts about the D-L3S Scoreboard

- three modules: middle part 2,400 x 1,800 mm, sides 2 x 800 x 1,800 mm Digits (LED) in three colors: red, green and yellow, white captions
- running time in minutes and seconds (up/down, green 30 cm digits); during last minute display in seconds and 1/10
- daytime can be displayed on the game time field
- time can be displayed in the game time field
- scores: 0 to 199 for each team (red 30 cm digits)
- period: 0 to 9 (yellow 25 cm digit)
- team fouls: 0 to 9 for each team (yellow 25 cm digits)
- LED cluster: red LED cluster (4 cm diameter) for time-out, bonus, serve and/or ball possession
- personal Fouls: 12 players per team, per player 4 green and 1 red LED cluster (each 4 cm diameter)
- horn
- power supply: 110/220 VAC - 50/60 Hz
- dimensions: 4,000 x 1,800 x 70 mm
- weight: approx. 140 kg

Type of Sport

basketball, handball, volleyball, football, tennis, table tennis, etc.

Controller

D-CKN (standard) or D-CKN-TXA (option)



MULTISPORT SCOREBOARDS

D-L3SP

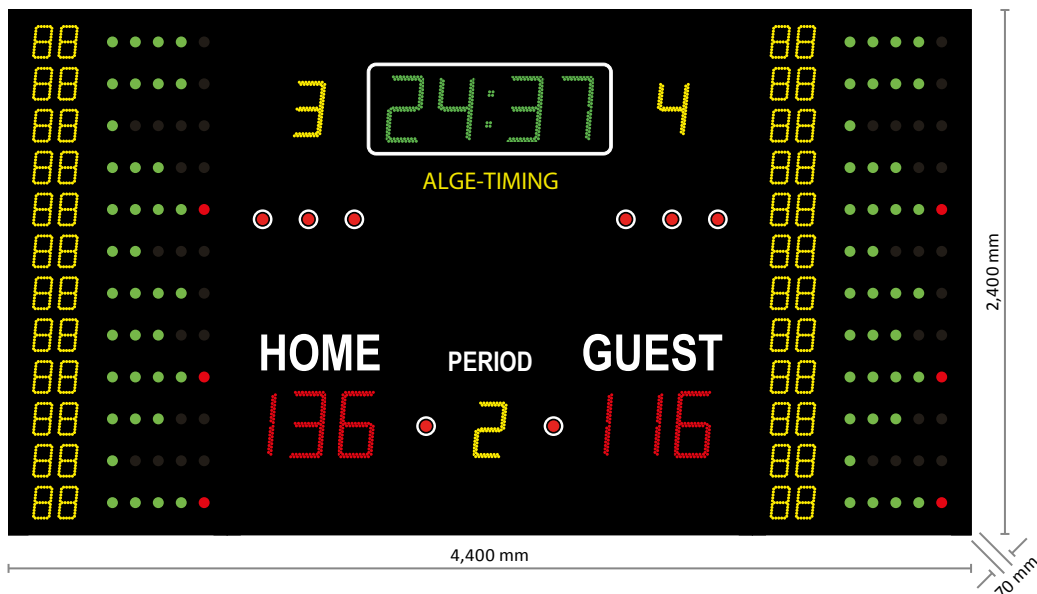

Facts about the D-L3SP Scoreboard

- three modules: middle section 2,400 x 2,400 mm, sides 2 x 1,000 x 2,400 mm
- digits (LED) in three colors: red, green and yellow, white captions
- running time in minutes and seconds (up/down, green 30 cm digits); during last minute display in seconds and 1/10
- daytime can be displayed on the game time field
- time can be displayed in the game time field
- scores: 0 to 199 for each team (red 30 cm digits)
- period: 0 to 9 (yellow 25 cm digit)
- team fouls: 0 to 9 for each team (yellow 25 cm digits)
- personal fouls: 12 players per team with adjustable number of players (0 - 99; yellow 15 cm digits), per player 4 green and 1 red LED cluster (4 cm diameter each)
- LED cluster: red LED cluster (4 cm diameter) for time-out, bonus, serve and/or ball possession
- horn
- power supply: 110/220 VAC - 50/60 Hz
- dimensions: 4,400 x 2,400 x 70 mm
- weight: approx. 210 kg

Type of Sport

basketball, handball, volleyball, football, tennis, table tennis, etc.

Controller

D-CKN (standard) or D-CKN-TXA (option)

MULTISPORT SCOREBOARDS

D-L4SH2

0:00:00

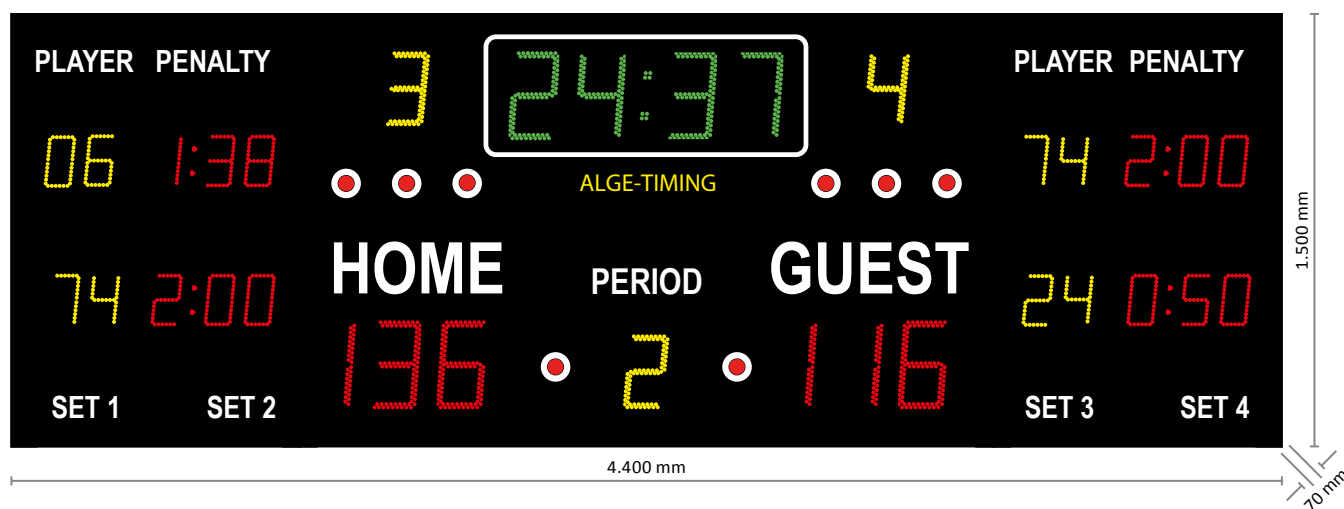

Facts about the D-L4SH2 Scoreboard

- three modules: middle section 2,400 x 1,500 mm, sides 2 x 1,000 x 1,500 mm
- digits (LED) in three colors: red, green and yellow, white captions
- running time in minutes and seconds (up/down, green 30 cm digits); during last minute display in seconds and 1/10
- daytime can be displayed on the game time field
- time can be displayed in the game time field
- scores: 0 to 199 for each team (red 30 cm digits)
- period: 0 to 9 (yellow 25 cm digit)
- team fouls: 0 to 9 for each team (yellow 25 cm digits)
- LED cluster: red LED cluster (4 cm diameter) for time-out, bonus, serve and/or ball possession
- penalties: 2 x 0 to 9:59 per team (red 18 cm digits)
- player number for penalties: 2 x 0 to 99 per team (yellow 18 cm digits)
- horn
- power supply: 110/220 VAC - 50/60 Hz
- dimensions: 4,400 x 1,500 x 70 mm
- weight: approx. 130 kg

Basketball

- team fouls: 0 to 9 (yellow 25 cm digits)
- player ID: 0 to 99 (yellow 18 cm digits)
- personal fouls: 0 to 99 (red 18 cm digits)

Volleyball, Table Tennis and Tennis

- score per set: 2 x 0 to 99 (18 cm digits)

Handball and Hockey

- player ID: 0 to 99 (yellow 18 cm digits)
- player foul: 0 to 9:59 (red 18 cm digits)

Type of Sport

basketball, handball, volleyball, football, tennis, table tennis, etc.

Controller

D-CKN (standard) or D-CKN-TXA (option)



MULTISPORT SCOREBOARDS

D-L4SV2

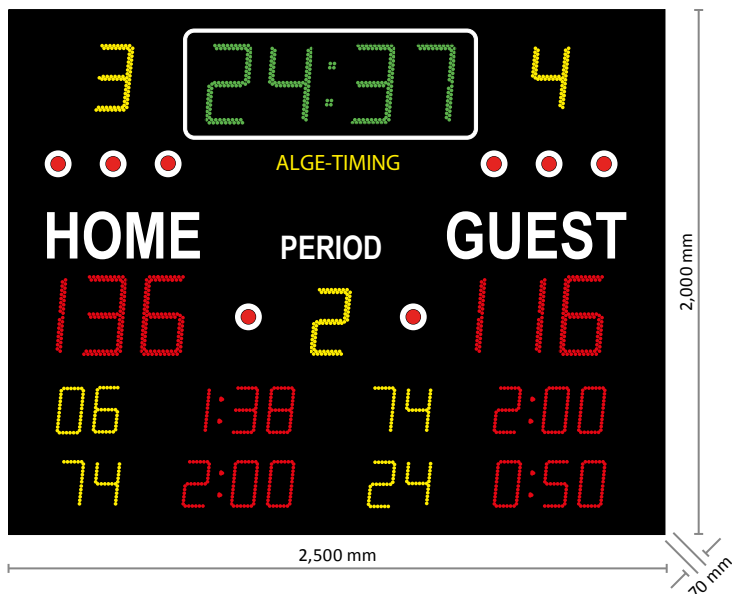

Facts about the D-L4SV2 Scoreboard

- digits (LED) in three colors: red, green and yellow, white captions
- running time in minutes and seconds (up/down, green 30 cm digits); during last minute display in seconds and 1/10
- daytime can be displayed on the game time field
- time can be displayed in the game time field
- scores: 0 to 199 for each team (red 30 cm digits)
- period: 0 to 9 (yellow 25 cm digit)
- team fouls: 0 to 9 for each team (yellow 25 cm digits)
- LED cluster: red LED cluster (4 cm diameter) for time-out, bonus, serve and/or ball possession
- penalties: 2 x 0 to 9:59 per team (red 18 cm digits)
- player number for penalties: 2 x 0 to 99 per team (yellow 18 cm digits)
- horn
- power supply: 110/220 VAC - 50/60 Hz
- dimensions: 2,500 x 2,000 x 70 mm
- weight: approx. 100 kg

Basketball

- team fouls: 0 to 9 (yellow 25 cm digits)
- player ID: 0 to 99 (yellow 18 cm digits)
- personal fouls: 0 to 99 (red 18 cm digits)

Volleyball, Table Tennis and Tennis

- score per set: 2 x 0 to 99 (18 cm digits)

Handball and Hockey

- player ID: 0 to 99 (yellow 18 cm digits)
- player foul: 0 to 9:59 (red 18 cm digits)

Type of Sport

basketball, handball, volleyball, football, tennis, table tennis, etc.

Controller

D-CKN (standard) or D-CKN-TXA (option)

MULTISPORT SCOREBOARDS

D-L5S

0:00:00

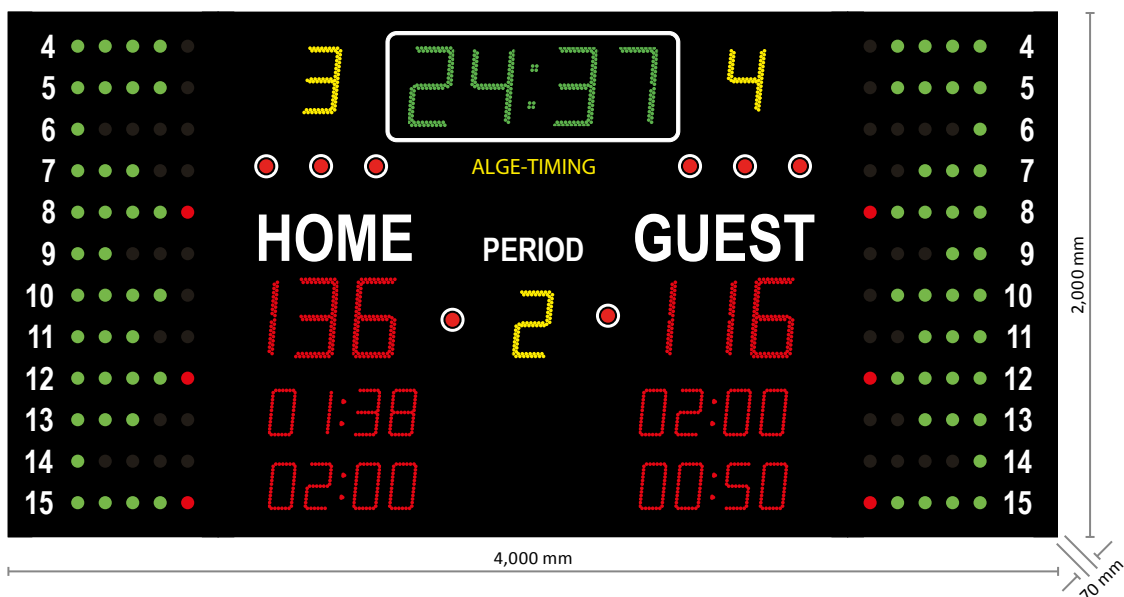

Facts about the D-L5S Scoreboard

- three modules: middle section 2,400 x 2,000 mm, sides 2 x 800 x 2,000 mm
- digits (LED) in three colors: red, green and yellow, white captions
- running time in minutes and seconds (up/down, green 30 cm digits); during last minute display in seconds and 1/10
- daytime can be displayed on the game time field
- time can be displayed in the game time field
- scores: 0 to 199 for each team (red 30 cm digits)
- period: 0 to 9 (yellow 25 cm digit)
- team fouls: 0 to 9 for each team (yellow 25 cm digits)
- LED cluster: red LED cluster (4 cm diameter) for time-out, bonus, serve and/or ball possession
- penalties: 2 x 0 to 99:59 per team, per player 4 green and 1 red LED cluster (each 4 cm diameter)
- horn
- power supply: 110/220 VAC - 50/60 Hz
- dimensions: 4,000 x 2,000 x 70 mm
- weight: approx. 155 kg

Type of Sport

basketball, handball, volleyball, football, tennis, table tennis, etc.

Controller

D-CKN (standard) or D-CKN-TXA (option)



MULTISPORT SCOREBOARDS

D-L6S

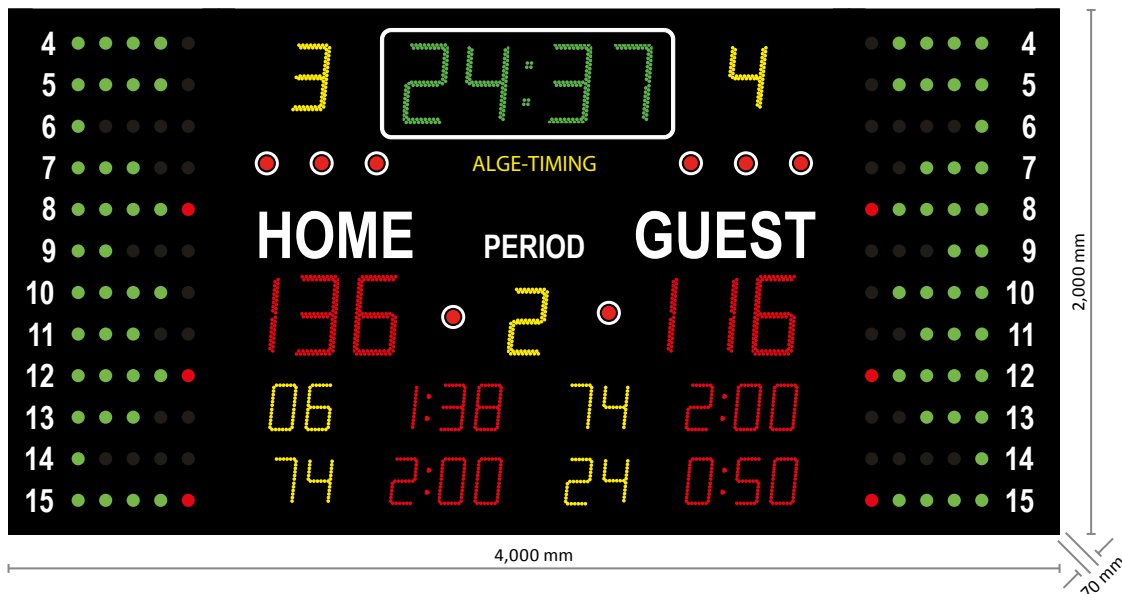

Facts about the D-L6S Scoreboard

- three modules: middle section 2,400 x 2,000 mm, sides 2 x 800 x 2,000 mm
- digits (LED) in three colors: red, green and yellow, white captions
- running time in minutes and seconds (up/down, green 30 cm digits); during last minute display in seconds and 1/10
- daytime can be displayed on the game time field
- time can be displayed in the game time field
- score: 0 to 199 for each team (red 30 cm digits)
- period: 0 to 9 (yellow 25 cm digit)
- team fouls: 0 to 9 for each team (yellow 25 cm digits)
- LED cluster: red LED cluster (4 cm diameter) for time-out, bonus, serve and/or ball possession
- penalties: 2 x 0 to 9:59 per team (red 18 cm digits)
- player number for penalties: 2 x 0 to 99 per team (yellow 18 cm digits)
- personal fouls: 12 players per team, per player 4 green and 1 red LED cluster (each 4 cm diameter)
- horn
- power supply: 110/220 VAC - 50/60 Hz
- dimensions: 4,000 x 2,000 x 70 mm
- weight: approx. 155 kg

Volleyball, Table Tennis and Tennis

- score per set: 2 x 0 to 99 (18 cm digits)

Handball and Hockey

- player ID: 0 to 99 (yellow 18 cm digits)
- player foul: 0 to 9:59 (red 18 cm digits)

Type of Sport

basketball, handball, volleyball, football, tennis, table tennis, etc.

Controller

D-CKN (standard) or D-CKN-TXA (option)

MULTISPORT SCOREBOARDS

D-L6SP

0:00:00

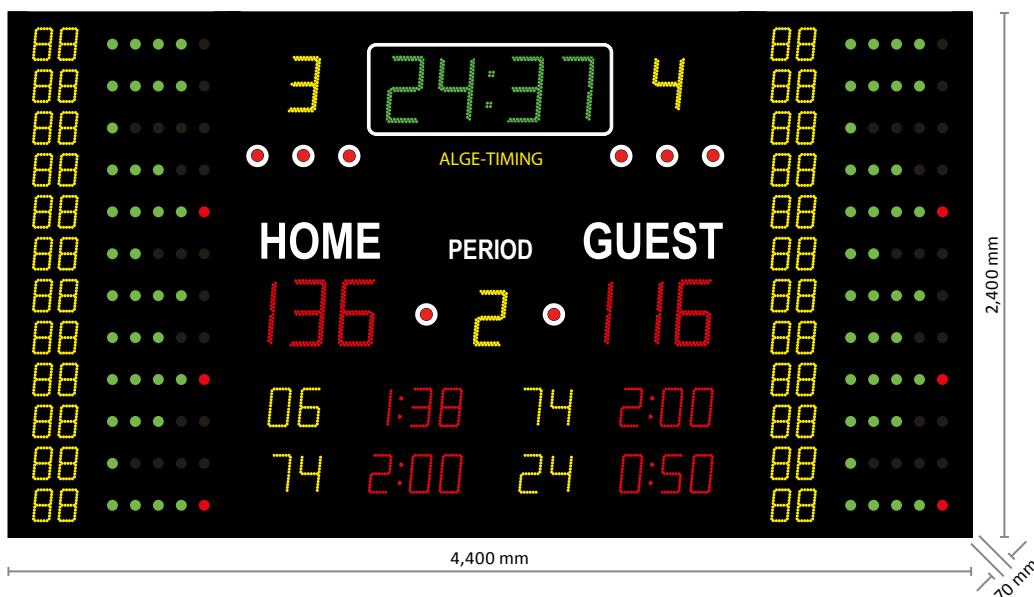

Facts about the D-L6SP Scoreboard

- three modules: middle section 2,400 x 2,400 mm, sides 2 x 1,000 x 2,400 mm
- digits (LED) in three colors: red, green and yellow, white captions
- running time in minutes and seconds (up/down, green 30 cm digits); during last minute display in seconds and 1/10
- daytime can be displayed on the game time field
- time can be displayed in the game time field
- score: 0 to 199 for each team (red 30 cm digits)
- period: 0 to 9 (yellow 25 cm digit)
- team fouls: 0 to 9 for each team (yellow 25 cm digits)
- LED cluster: red LED cluster (4 cm diameter) for time-out, bonus, serve and/or ball possession
- penalties: 2 x 0 to 9:59 per team (red 18 cm digits)
- player number for penalties: 2 x 0 to 99 per team (yellow 18 cm digits)
- statistics for 12 players per team (all digits 15 cm):
 - player ID: 0 to 99 (yellow digits)
 - personal fouls: 5 LED cluster (4 cm diameter, 4 x green, 1 x red)
- horn
- power supply: 110/220 VAC - 50/60 Hz
- dimensions: 4,400 x 2,400 x 70 mm
- weight: approx. 210 kg

Volleyball, Table Tennis and Tennis

- score per set: 2 x 0 to 99 (18 cm digits)

Handball and Hockey

- player ID: 0 to 99 (yellow 18 cm digits)
- player foul: 0 to 9:59 (red 18 cm digits)

Type of Sport

basketball, handball, volleyball, football, tennis, table tennis, etc.

Controller

D-CKN (standard) or D-CKN-TXA (option)



MULTISPORT SCOREBOARDS

D-L6SPP

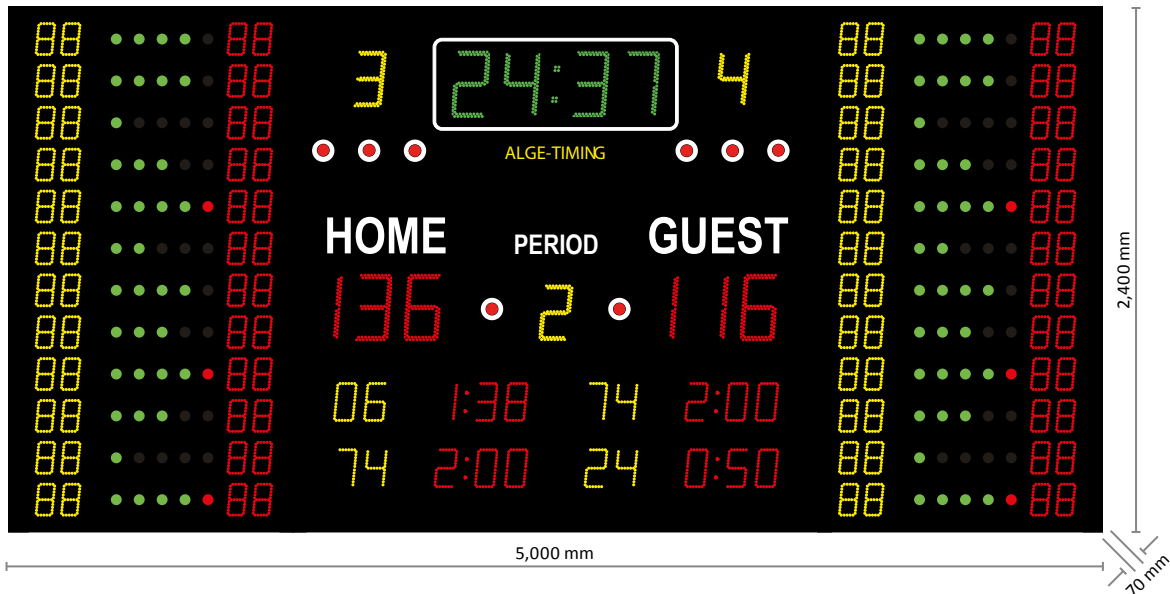

Facts of the D-L6SPP Scoreboard

- three modules: middle section 2,400 x 2,400 mm, sides 2 x 1,300 x 2,400 mm
- digits (LED) in three colors: red, green and yellow, white captions
- running time in minutes and seconds (up/down, green 30 cm digits); during last minute display in seconds and 1/10
- daytime can be displayed on the game time field
- time can be displayed in the game time field
- score: 0 to 199 for each team (red 30 cm digits)
- period: 0 to 9 (yellow 25 cm digit)
- team fouls: 0 to 9 for each team (yellow 25 cm digits)
- LED cluster: red LED cluster (4 cm diameter) for time-out, bonus, serve and/or ball possession
- penalties: 2 x 0 to 9:59 per team (red 18 cm digits)
- player number for penalties: 2 x 0 to 99 per team (yellow 18 cm digits)
- statistics for 12 players per team (all digits 15 cm):
 - player ID: 0 to 99 (yellow digits)
 - personal fouls: 5 LED cluster (4 cm diameter, 4 x green, 1 x red)
 - points: 0 to 99 (red digits) horn
- power supply: 110/220 VAC - 50/60 Hz
- dimensions: 5,000 x 2,400 x 70 mm
- weight: approx. 240 kg

Volleyball, Table Tennis and Tennis

- score per set: 2 x 0 to 99 (18 cm digits)

Handball and Hockey

- player ID: 0 to 99 (yellow 18 cm digits)
- player foul: 0 to 9:59 (red 18 cm digits)

Type of Sport

basketball, handball, volleyball, football, tennis, table tennis, etc.

Controller

D-CKN (standard) or D-CKN-TXA (option)

MULTISPORT SCOREBOARDS

D-L6SPFP

00:00:00

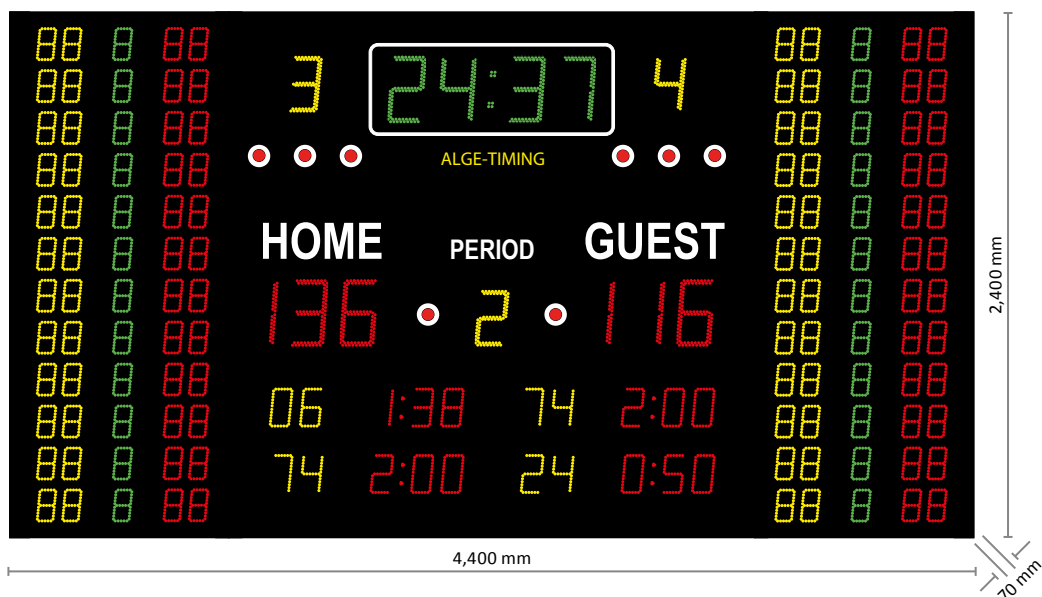

Facts about the D-L6SPFP Scoreboard

- three modules: middle section 2,400 x 2,400 mm, sides 2 x 1,000 x 2,400 mm
- digits (LED) in three colors: red, green and yellow, white captions
- running time in minutes and seconds (up/down, green 30 cm digits); during last minute display in seconds and 1/10
- daytime can be displayed on the game time field
- time can be displayed in the game time field
- score: 0 to 199 for each team (red 30 cm digits)
- period: 0 to 9 (yellow 25 cm digit)
- team fouls: 0 to 9 for each team (yellow 25 cm digits)
- LED cluster: red LED cluster (4 cm diameter) for time-out, bonus, serve and/or ball possession
- penalties: 2 x 0 to 9:59 per team (red 18 cm digits)
- player number for penalties: 2 x 0 to 99 per team (yellow 18 cm digits)
- statistics for 12 players per team (all digits 15 cm):
 - player ID: 0 to 99 (yellow digits)
 - personal fouls: 0 to 9 (green digit)
 - points: 0 to 99 (red digits)
- horn
- power supply: 110/220 VAC - 50/60 Hz
- dimensions: 4,400 x 2,400 x 70 mm
- weight: approx. 210 kg

Volleyball, Table Tennis and Tennis

- score per set: 2 x 0 to 99 (18 cm digits)

Handball and Hockey

- player ID: 0 to 99 (yellow 18 cm digits)
- player foul: 0 to 9:59 (red 18 cm digits)

Type of Sport

basketball, handball, volleyball, football, tennis, table tennis, etc.

Controller

D-CKN (standard) or D-CKN-TXA (option)



MULTISPORT SCOREBOARDS

D-LS-BHV-H

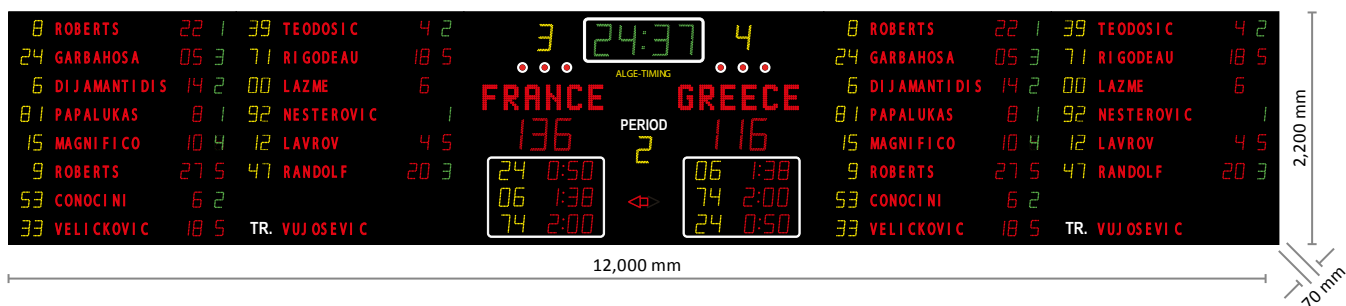

Facts about the D-LS-BHV-H Scoreboard

- 5 modules: middle section 3,400 x 2,200 mm, sides 4 x 2,150 x 2,200 mm
- digits (LED) in three colors: red, green and yellow, white captions
- running time in minutes and seconds (up/down, green 30 cm digits); during last minute display in seconds and 1/10
- daytime can be displayed on the game time field
- time can be displayed in the game time field
- score: 0 to 199 for each team (red 30 cm digits)
- period: 0 to 9 (yellow 25 cm digit)
- team fouls: 0 to 9 for each team (yellow 25 cm digits)
- team name: 6 alphanumeric characters per team (red 25 cm characters)
- LED cluster: 3 x red LED cluster per team (4 cm diameter) for time-out
- arrow for displaying the team with ball possession
- penalties: 3 x 0 to 9:59 per team (red 18 cm digits)
- player number for penalties: 3 x 0 to 99 per team (yellow 18 cm digits)
- statistics for 14 players per team (all digits 15 cm)
 - player ID: 0 to 99 (yellow digits)
 - player name: 12 alphanumeric characters (red characters)
 - points: 0 to 99 (red digits)
 - personal fouls: 0 to 9 (green or red digit)
 - trainer: 12 alphanumeric characters (red digits)
- horn
- power supply: 110/220 VAC - 50/60 Hz
- dimensions: 12,000 x 2,200 x 70 mm
- weight: approx. 520 kg

Type of Sport

basketball, handball, volleyball, football, tennis, table tennis, etc.

Controller

D-CKN (standard) or D-CKN-TXA (option)

MULTISPORT SCOREBOARDS

D-LS-BHV-V

0:00:00



Facts about the D-LS-BHV-H Scoreboard

- three modules: middle section 3,000 x 3,000 mm, sides 2 x 2,400 x 3,000 mm
- digits (LED) in three colors: red, green and yellow, white captions
- running time in minutes and seconds (up/down, green 30 cm digits); during last minute display in seconds and 1/10
- daytime can be displayed in the game time field
- time can be displayed in the game time field
- score: 0 to 199 for each team (red 30 cm digits)
- period: 0 to 9 (yellow 25 cm digit)
- team fouls: 0 to 9 for each team (yellow 25 cm digits)
- team name: 6 alphanumeric characters per team (red 25 cm characters)
- LED cluster: 3 x red LED cluster per team (4 cm diameter) for time-out
- LED cluster: 1 x red LED cluster per team (4 cm diameter) for ball possession (or surcharge)
- penalties: 3 x 0 to 9:59 per team (red 18 cm digits)
- player number for penalties: 3 x 0 to 99 per team (yellow 18 cm digits)
- statistics for 14 players per team (all digits 18 cm):
 - player ID: 0 to 99 (yellow digits)
 - player name: 12 alphanumeric characters (red digits)
 - points: 0 to 99 (red digits)
 - personal fouls: 0 to 9 (green or red digit)
- horn
- power supply: 110/220 VAC - 50/60 Hz
- dimensions: 7,800 x 3,000 x 70 mm
- weight: approx. 460 kg

Type of Sport

basketball, handball, volleyball, football, tennis, table tennis, etc.

Controller

D-CKN (standard) or D-CKN-TXA (option)



MULTISPORT SCOREBOARDS

D-LS-FIBA

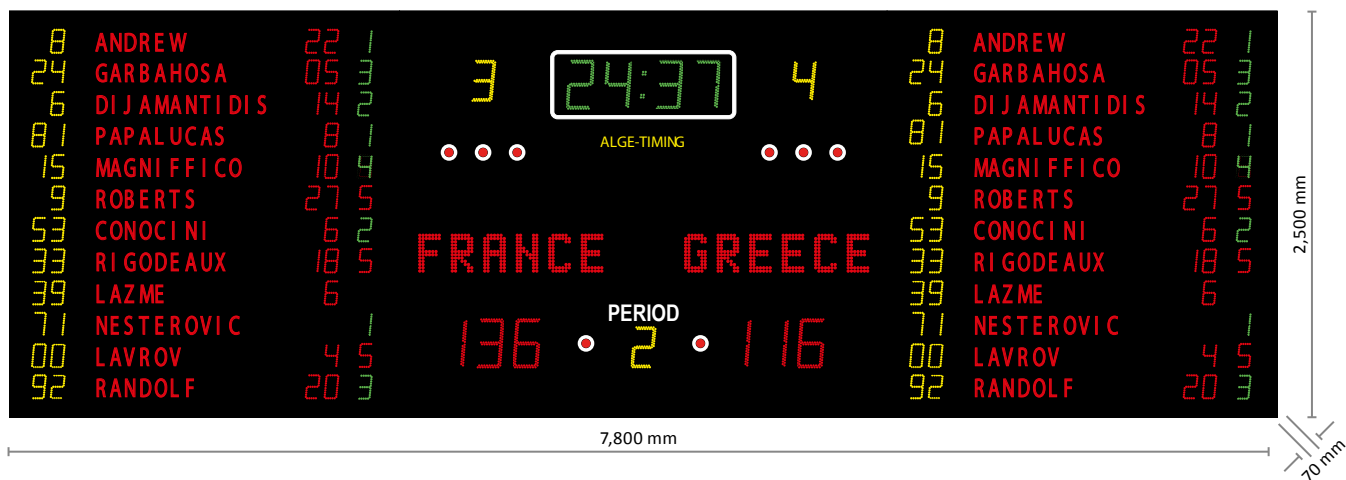

Facts about the D-LS-FIBA Scoreboard

- three modules: middle section 3,000 x 2,500 mm, sides 2 x 2,400 x 2,500 mm
- digits (LED) in three colors: red, green and yellow, white captions
- running time in minutes and seconds (up/down, green 30 cm digits); during last minute display in seconds and 1/10
- daytime can be displayed on the game time field
- time can be displayed on the game time field
- score: 0 to 199 for each team (red 30 cm digits)
- period: 0 to 9 (yellow 25 cm digit)
- team fouls: 0 to 9 for each team (yellow 25 cm digits)
- team name: 6 alphanumeric characters per team (red 25 cm characters)
- LED cluster: 3 x red LED cluster per team (4 cm diameter) for time-out
- LED cluster: 1 x red LED cluster per team (4 cm diameter) for ball possession (or surcharge)
- penalties: 3 x 0 to 9:59 per team (red 18 cm digits)
- statistics for 12 players per team (all digits 15 cm):
 - player ID: 0 to 99 (yellow digits)
 - player name: 12 alphanumeric characters (red digits)
 - points: 0 to 99 (red digits)
 - personal fouls: 0 to 9 (green or red digit)
- horn
- power supply: 110/220 VAC - 50/60 Hz
- dimensions: 7,800 x 2,500 x 70 mm
- weight: approx. 380 kg

Type of Sport

basketball, handball, volleyball, football, tennis, table tennis, etc.

Controller

D-CKN (standard) or D-CKN-TXA (option)

MULTISPORT SCOREBOARDS

Shot Clock D-SC

In basketball, the indoor shot clocks are combined with ALGE-TIMING multisport scoreboards. The set of shot clock always includes two pieces with horn, one controller with three buttons (start, 24 and 14 seconds reset), which is connected to the controller D-CKN of the Multisport display board, and a cable set. The supplied cable set consists of short cables for testing the system. Specific cable lengths are available at ALGE-TIMING.

Function

- shot clock horn honks when attack time has elapsed
- multisport display board horn honks when period has elapsed
- time-out possible
- LED cluster lights up for the D-SC25SF-PH at time-out
- no additional power supply required, power supply via scoreboard
- modular system
- models with extra loud horn available
- protected digits by metal frame - additional protection not necessary
- outdoor model available upon request
- shot clocks also available with two faces, three faces and as a cube



Shot Clock D-SC15S-PH

- shot clock: 0 - 99 seconds (red digits, 15 cm)
- integrated piezo-electronic horn (approx. 100 dB)
- dimensions: 340 x 250 x 70 mm
- weight: 2 kg



shot clock D-SC15S-PH



shot clock D-SC25S-PH

Shot Clock D-SC25S-PH

- shot clock: 0 - 99 seconds (red digits, 25 cm)
- integrated piezo-electronic horn (approx. 100 dB)
- dimensions: 450 x 350 x 70 mm
- weight: 3 kg

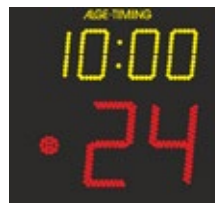

shot clock D-SC25SF-PH

Shot Clock D-SC25SF-PH

- game time: 99:59 minutes (yellow digits, 15 cm)
- shot clock: 0 - 99 seconds (red digits, 25 cm)
- LED cluster (red, 8 cm): lights when horn honks
- horn with approx. 100 dB
- dimensions: 650 x 600 x 70 mm
- weight: 12 kg





MULTISPORT SCOREBOARDS

Basketball System

End-of-period Light D-EPL2

If a D-EPL2 is installed at the basketball backboards behind the baskets, the D-EPL2 light will turn red at the end of each period.

The dimensions and design of the D-EPL2 is always adapted to the basketball backboard.



A system for basketball can consist of several multisport scoreboards, shot clocks and end of period lights D-EPL2. The sketch below shows such a system.

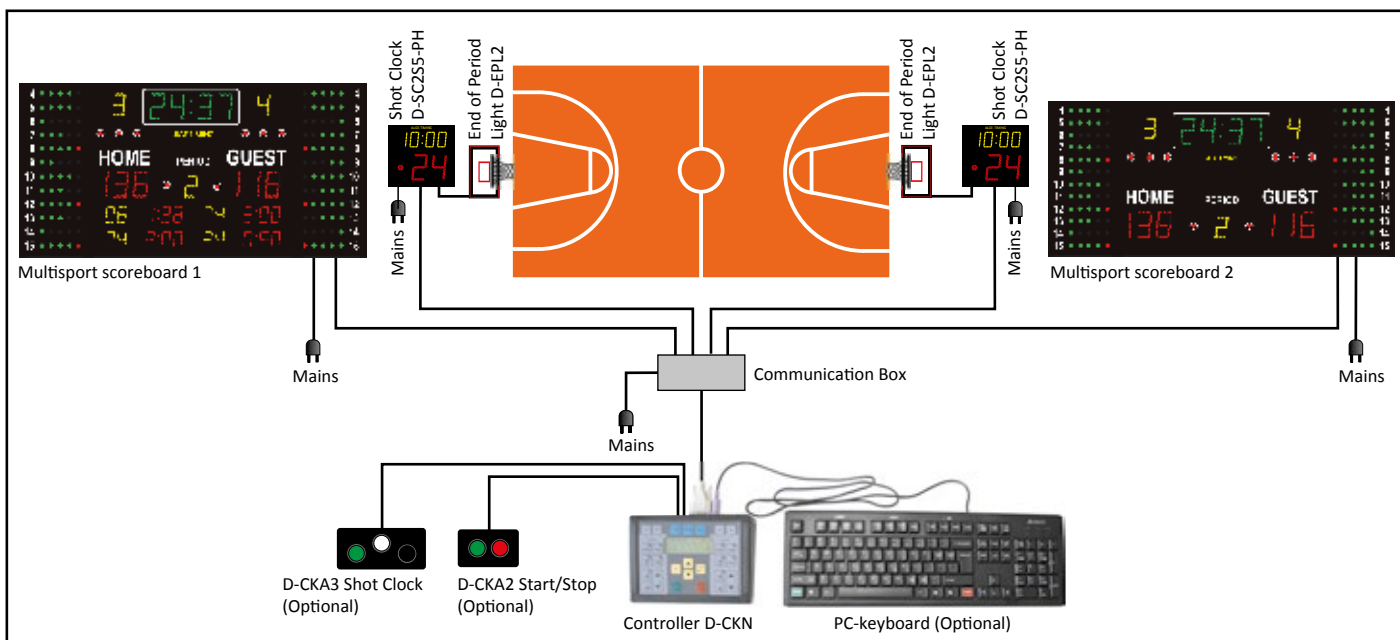

Basketball System: 2 x multi-port + 2 x D-SC255F-PH + 2 x D-EPL2

ICE HOCKEY

D-M4SH2H and D-M5SH2H

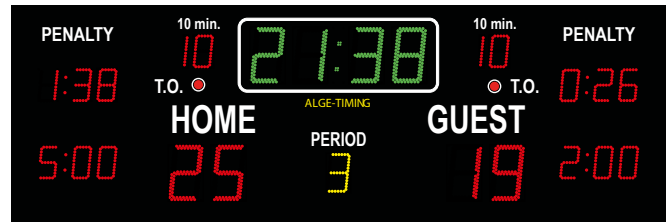
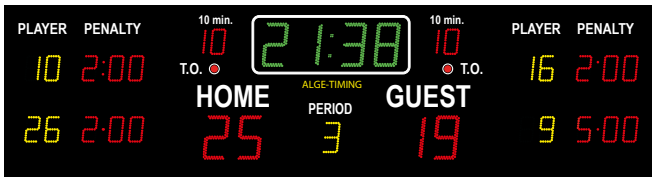

Ice Hockey Scoreboard for Indoor (D-M4SH2H) and Outdoor (D-M4SH2H-O)

- three modules: middle section 2,000 x 1,000 mm, sides 2 x 900 x 1,000 mm
- digits (LED) in three colors: red, green and yellow, white captions
- running time in minutes and seconds (up/down, green 25 cm digits); shows 1/10 seconds during last minute
- daytime can be displayed on the game time field
- time can be displayed in the game time field
- score: 0 to 99 for each team (red 25 cm digits)
- period: 0 to 9 (yellow 18 cm digit)
- 10 minutes fouls: 0 to 19 for each team (red 15 cm digits)
- penalties: 2 x per team, 0 to 9:59 (red 15 cm digits)
- player number for penalty: 2 x per team, 0 to 99 (yellow 15 cm digits)
- timeout: 1 LED cluster per team with 2 cm diameter
- horn
- power supply: 110/220 VAC - 50/60 Hz
- dimensions: 3,800 x 1,000 x 70 mm
- weight: 75 kg

Controller

D-CKN (standard) or D-CKN-TXA (option)

Ice Hockey Scoreboard for Indoor (D-M5SH2H) and Outdoor (D-M5SH2H-O)

- the display board consists of one module
- digits (LED) in three colors: red, green and yellow, white captions
- running time in minutes and seconds (up/down, green 25 cm digits); shows 1/10 seconds during last minute
- daytime can be displayed on the game time field
- time can be displayed in the game time field
- score: 0 to 99 for each team (red 25 cm digits)
- period: 0 to 9 (yellow 18 cm digit)
- penalties: 2 x per team, 0 to 9:59 (red 15 cm digits)
- 10 minutes fouls: 0 to 19 for each team (red 15 cm digits)
- timeout: 1 LED cluster per team with 2 cm diameter
- horn
- power supply: 110/220 VAC - 50/60 Hz
- dimensions: 3,000 x 1,000 x 70 mm
- weight: 60 kg

Controller

D-CKN (standard) or D-CKN-TXA (option)



ICE HOCKEY

D-L4SH2H and D-L5SH2H

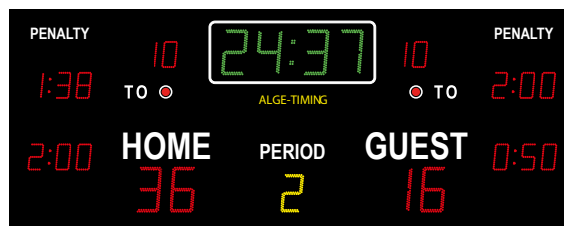
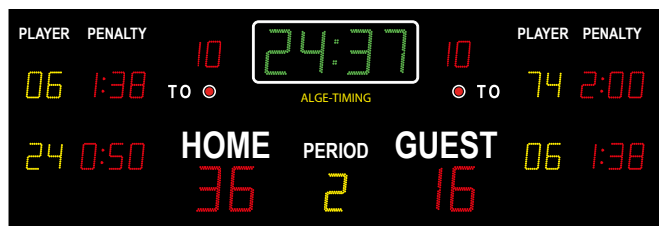

Ice Hockey Scoreboard for Indoor (D-L4SH2H) and Outdoor (D-L4SH2H-O)

- three modules: middle section 2,400 x 1,500 mm, sides 2 x 1,000 x 1,500 mm
- digits (LED) in three colors: red, green and yellow, white captions
- running time in minutes and seconds (up/down, green 30 cm digits); shows 1/10 seconds during last minute
- daytime can be displayed on the game time field
- time can be displayed in the game time field
- score: 0 to 99 for each team (red 30 cm digits)
- period: 0 to 9 (yellow 25 cm digit)
- 10 minutes fouls: 0 to 19 for each team (red 18 cm digits)
- penalties: 2 x per team, 0 to 9:59 (red 18 cm digits)
- player number for penalty: 2 x per team, 0 to 99 (yellow 18 cm digits)
- timeout: 1 LED cluster per team with 4 cm diameter
- horn
- power supply: 110/220 VAC - 50/60 Hz
- dimensions: 4,400 x 1,500 x 70 mm
- weight: 130 kg

Controller

D-CKN (standard) or D-CKN-TXA (option)

Ice Hockey Scoreboard for Indoor (D-L5SH2H) and Outdoor (D-L5SH2H-O)

- three modules: middle section 2,400 x 1,500 mm, sides 2 x 900 x 1,500 mm
- digits (LED) in three colors: red, green and yellow, white captions
- running time in minutes and seconds (up/down, green 30 cm digits); shows 1/10 seconds during last minute
- daytime can be displayed on the game time field
- time can be displayed in the game time field
- score: 0 to 99 for each team (red 30 cm digits)
- period: 0 to 9 (yellow 25 cm digit)
- 10 minutes fouls: 0 to 19 for each team (red 18 cm digits)
- penalties: 2 x per team, 0 to 9:59 (red 18 cm digits)
- timeout: 1 LED cluster per team with 4 cm diameter
- horn
- power supply: 110/220 VAC - 50/60 Hz
- dimensions: 3,800 x 1,500 x 70 mm
- weight: 110 kg

Controller

D-CKN (standard) or D-CKN-TXA (option)

ICE HOCKEY

Accessories



Ice hockey scoreboards are used indoors and outdoors, and must meet appropriate criteria, depending on the application, in order to be easily readable and guarantee a secure data transmission.

- extra bright LEDs for models for outdoor areas, so that the display is easy to read even in direct sunlight
- flexibility through data transmission by radio from the controller D-CKN-TXA to the scoreboard
- each model also available with integrated LED text field to show the team names
- possibility of four-sided cube scoreboard systems to mount in the center of the ice stadium
- scoreboard with attached matrix-display board to show information (e.g. team lineup, scorer, advertising, etc.)
- scoreboard with integrated video wall

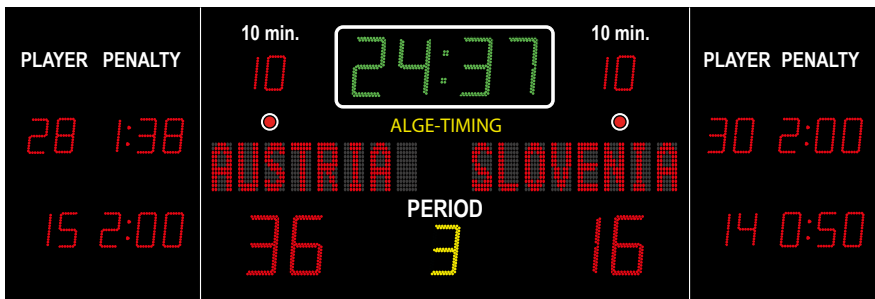

Hockey Goal Light D-HGL

The goal light consists of a red and green light, which is installed behind each goal. A goal judge operates the goal light to indicate to the referee his decision. Goal lights have to be used by the rules for international hockey games, but also many national leagues demand a goal light.





Model D-BVDT-S2

Attempt, Decision Light and Timer Board

Dimensions: 1,100 x 600 x 70 mm

Weight: 15 kg

Display

Time, weight, attempt: 100 mm LED digits

Referees' light system: 6 LED clusters, with a diameter of 20 mm each

Caption: digit height 60 mm (language can be selected)

Power supply: 100 - 240 VAC



Model D-BVDT-S1

Attempt, Decision Light and Timer Board

Dimensions: 1,100 x 800 x 70 mm

Weight: 20 kg

Display

Time, weight, attempt: 100 mm LED digits

Contestant name: 100 mm caption height (nine letters)

Contestant country: 100 mm letter height (three letters)

Referees' light system: 6 LED clusters, with a diameter of 20 mm each

Caption: digit height 60 mm (language can be selected)

Power supply: 100 - 240 VAC



Decision Light Table DL2

with three white and three red lights indicating the decision of the referees



Down' Apparatus

acoustic and visual "down" signal



Referee Boxes

three referee boxes with two buttons each (white and red) and acoustic signal

Controller

D-CKN (standard) or D-CKN-TXA (option)



Model D-BVJ

| | |
|---------------------|--|
| Dimensions: | 1,200 x 800 x 70 mm |
| Weight: | 20 kg |
| Scoreboard digit: | extra bright LED digits, digit height 100 mm |
| Osaekomi: | extra bright LED digits, digit height 100 mm |
| Penalties & winner: | LED cluster, 20 mm diameter |
| Power supply: | 110 - 220 VAC - 50 Hz |

Display

- result (Wazari, Yuko, Koka): display in numbers
- contest time
- winner indicator light
- penalty indicator light (Keykoka, Cuji, Sido)
- ipon indicator lights



Model D-BVJ-CT

| | |
|---------------------|--|
| Dimensions: | 1,400 x 800 x 70 mm |
| Weight: | 25 kg |
| Scoreboard digit: | extra bright LED digits, digit height 100 mm |
| Osaekomi: | extra bright LED digits, digit height 100 mm |
| Penalties & winner: | LED cluster, 20 mm diameter |
| Power supply: | 110 - 220 VAC - 50 Hz |

Display

- result (Wazari, Yuko, Koka): display in numbers
- contest time
- winner indicator light
- penalty indicator light (Keykoka, Cuji, Sido)
- ipon indicator lights
- participant's country (2 x 3 characters)



Model D-BVJ-CT

| | |
|---------------------|--|
| Dimensions: | 1,800 x 900 x 70 mm |
| Weight: | 40 kg |
| Scoreboard digit: | extra bright LED digits, digit height 100 mm |
| Osaekomi: | extra bright LED digits, digit height 100 mm |
| Penalties & winner: | LED cluster, 20 mm diameter |
| Power supply: | 110 - 220 VAC - 50 Hz |

Display

- result (Wazari, Yuko, Koka): display in numbers
- contest time
- winner indicator light
- penalty indicator light (Keykoka, Cuji, Sido)
- ipon indicator lights
- participant's name (2 x 9 characters) and country (2 x 3 characters)

Options

- DS - double-sided display board
- ST - stand with 4 wheels for mounting the display board

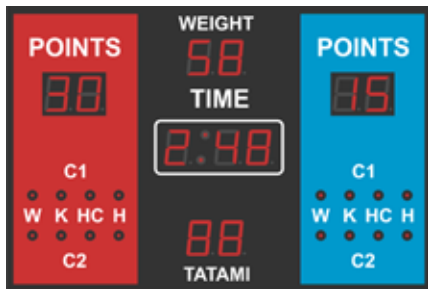

Model D-BVK

Dimensions: 1,200 x 800 x 70 mm
 Weight: approx. 25 kg
 Digit: extra bright LED, height 100 mm
 Penalties C1 & C2
 (W, K, HC, H): 20 mm LED cluster
 Power supply: 110 - 220 VAC - 50 Hz

Display

- score (Shiro & Aka): display in numbers
- current time of round
- penalty point indicator lights
- weight display
- tatami display

Game Judge Voting Console

The voting console for the five judges (1 red button and 1 blue button) allows them to vote during kata.

Options

- DS - Double-sided scoreboard
- ST - stand with 4 wheels for mounting the scoreboard
- controller with radio



Model D-BVK-CT

Dimensions: 1,400 x 800 x 70 mm
 Weight: approx. 30 kg
 Digit: extra bright LED, digit height 100 mm
 Penalties C1 & C2
 (W, K, HC, H): 20 mm LED cluster
 Power supply: 110 - 220 VAC - 50 Hz

Display

- score (Shiro & Aka): display in numbers
- current time of round
- penalty point indicator lights
- weight display
- tatami display
- participant's country (2 x 3 characters)

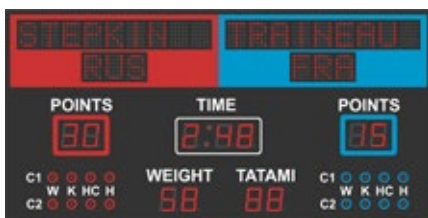

Model D-BVK-T

Dimensions: 1,800 x 900 x 70 mm
 Weight: approx. 40 kg
 Digit: extra bright LED, digit height 100 mm
 Penalties C1 & C2
 (W, K, HC, H): 20 mm LED cluster
 Power supply: 110 - 220 VAC - 50 Hz

Display

- score (Shiro & Aka): display in numbers
- current time of round
- penalty point indicator lights
- weight display
- tatami display
- extension name (2 x 9 characters)
- participant's country (2 x 3 characters)

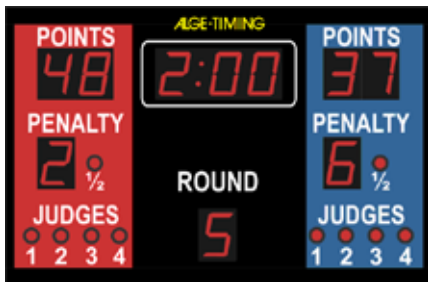

model D-BVT-0

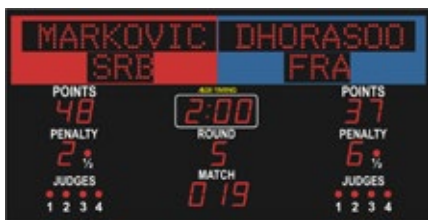

model D-BAT



model D-BVT-CT

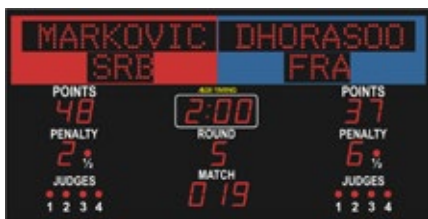

model D-BVT-T

Model D-BVT-0

- dimensions: 1,000 x 650 x 70 mm
- weight: 13 kg

Model D-BAT

- dimensions: 1,000 x 650 x 70 mm
- weight: 13 kg

Model D-BVT-CT

- dimensions: 1,200 x 800 x 70 mm
- weight: 20 kg

Model D-BVT-T

- dimensions: 1,800 x 900 x 70 mm
- weight: 40 kg

All models

- digits: red LED, digit height 100 mm
- judges 1, 2, 3, 4 penalty 1/2: LED cluster, 20 mm diameter
- power supply: 110 - 220 VAC - 50 Hz

Display of all models

- red (Hong) - result in numbers
- blue (Chung) - result in numbers
- time of round
- round number
- full points deductions (gam-jeom)
- judge lights
- half point deduction (kyung-go) indicators

Model D-BAT

- additional match number

Model D-BVT-CT

- additional match number
- nation (2 x 3 characters)

Model D-BVT-T

- additional match number
- nation (2 x 3 characters)
- name (2 x 9 characters)

Controller

D-CKN (standard) or D-CKN-TXA (option)

Controller Functions

- scoreboard diagnostics
- adjustable time window for judging decisions - controls the time at which two judges must agree whether a point is scored
- point buzzer - the buzzer, which signals a point, can be switched off; when this function is disabled, loop and pause buffers are still active
- break length - adjustable time for the break
- round length - adjustable time for the rounds
- round number - adjustable number of rounds for a match

Options

- DS - double-sided scoreboard
- ST - stand with 4 wheels for mounting the scoreboard



NOTES

ALGE-TIMING
Rotkreuzstraße 39
6890 Lustenau, Austria
www.alge-timing.com